



# **Truck Hydraulics**

*Fixed and Variable Displacement  
Pumps, Motors and Accessories*

*Catalogue HY17-8200/UK  
March 2004*



**F1**

**F2**

**T1**

**VP1**

**PTO info**

**Accessories**

**Conversion factors**

|   |                      |
|---|----------------------|
| 1 kg  | 2.20 lb              |
| 1 N   | 0.225 lbf            |
| 1 Nm  | 0.738 lbf ft         |
| 1 bar                                       | 14.5 psi             |
| 1 l   | 0.264 US gallon      |
| 1 cm <sup>3</sup>                           | 0.061 cu in          |
| 1 mm  | 0.039 in             |
| $\frac{9}{5} \text{ }^{\circ}\text{C} + 32$ | 1 $^{\circ}\text{F}$ |

**General Information**

General information, design

**General Information**

Page 4 - 9

1

**Pump and line selection**

Installation guide lines

**Pump and line selection**

Page 10 - 13

2

**F1 Pump**

Fixed Displacement - Axial Piston Pump. ISO and SAE version

**F1**

Page 14 - 20

3

**F1 Motor**

Fixed Displacement - Axial Piston Motor.

**F1**

Page 21 - 22

4

**F2 Twin-flow pump**

Fixed Displacement - Axial Piston Pump

**F2**

Page 23 - 25

5

**T1 Pump**

Fixed Displacement - Axial Piston Pump.

**T1**

Page 26 - 29

6

**VP1 Pump**

Variable Displacement - Axial Piston Pump

**VP1**

Page 30 - 35

7

**BLA**

Boost units

**BLA**

Page 36

8

**Fittings**

Suction fittings and fitting kits

**Fittings**

Page 37 - 38

9

**Auxiliary Valves**

Bypass Valve, Unloading Valve and Torque limiter valve

**Auxiliary Valves**

Page 39 - 46

10

**Accessories**

Universal PTO air valve kits, PTO adapter kits for engines, Cardan shafts, pump couplings and mounting brackets, Return filter and filter indicator , Air breather filter, SB splitter boxes

**Accessories**

Page 47 - 59

11

**Installation and start up**

F1, F2, T1 and VP1

**Installation and start up**

Page 60 - 63

12

**PTO**

PTO's from Parker and Parker Chelsea

**PTO**

Page 64 - 65

13

# General Information

## F1 Pump ISO

Series F1 is a further development of our well known 'truck pump', the F1. The F1 offers many additional values for operators of cargo cranes, hook loaders, skip loaders, forest cranes, concrete mixers and similar truck applications.

Series F1 is a very efficient and straight forward pump design with unsurpassed reliability. Its small envelope size gives a simple and inexpensive installation.



### New features of the F1 are:

- Higher selfpriming speeds
- Operating pressures to 400 bar
- New frame sizes to meet market requirements
- Higher overall efficiency
- Increased reliability
- Reduced noise level
- Possible leakage paths reduced
- Easier to change direction of rotation
- Smaller installation dimensions

### ... thanks to:

- 45° bent-axis angle
- Optimal inlet port geometry
- New ball and roller bearings
- Single housing design
- Optimized commutation - low flow pulsations

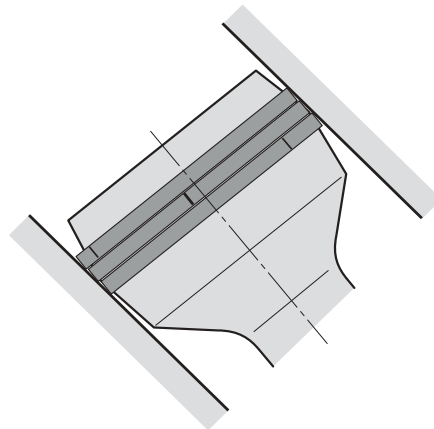

*F1 piston with laminated piston ring.*

### All of this in addition to previous F1 features:

- Spherical pistons - high speeds
- Laminated piston rings - low leakage
- Positive synchronization with timing gear
- Installation above the reservoir level possible
- Tolerates low temperatures and high temperature shocks
- Shaft end and mounting flange meet the ISO standard for all sizes

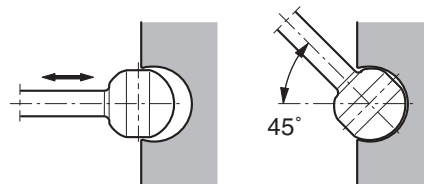

*F1 piston-to-shaft locking.*

See page 14

## F1 Pump SAE

### All of this in addition to previous F1 features:

- Spherical pistons - high speeds
- Laminated piston rings - low leakage
- Positive synchronization with timing gear
- Operating pressure 350 bar
- Installation above the reservoir level possible
- Tolerates low temperatures and high temperature shocks
- Shaft end and mounting flange meet the standard SAE-B for sizes 25 to 61

See page 18



1

## F1 Motor ISO

### All of this in addition to previous F1 features:

- Spherical pistons - high speeds
- Laminated piston rings - low leakage
- Positive synchronization with timing gear
- Operating pressure 250 bar
- Installation above the reservoir level possible
- Tolerates low temperatures and high temperature shocks
- Shaft end and mounting flange meet the ISO standard for all sizes

See page 21



## F2 Twin-flow pump

Series F2 is a further development of the twin-flow version of series F1, the very first bent-axis truck pump on the market to feature two entirely independent flows.

With a suitable build-up of the hydraulic system, the main advantage with a twin-flow pump is that three different flows can be provided at the same engine speed.

The twin-flow pump makes it possible to further optimize the hydraulic system and offers:

- Less energy consumption
- Reduced risk of system overheating
- Lower weight
- Easier installation
- Standardized system solutions

The twin-flow pump makes it possible to operate two work functions that are independent of each other which leads to higher speed and an increased operating precision.

Another requirement can be a large and a small flow, or two equal flows. All of these alternatives are possible with the twin-flow pump.

The pump can be utilized to provide one flow at high system pressure, and, as soon as the pressure has decreased sufficiently, add the flow from the other circuit.

This eliminates the risk of exceeding the PTO power rating and, at the same time, provide an optimal driving function.



### Typical twin-flow applications

- Large truck loaders
- Forestry cranes
- Hook loaders/lift dumpers
- Tipper/crane combinations
- Refuse collecting vehicles

The pump shaft end/mounting flange meets the ISO standard and suits PTO direct mounting. Suitable PTO:s for most European truck gearboxes are available from our sales offices and distributors.

**See page 23**

## T1 Pump

The T1 fixed displacement pump is a further development of series T1, which was specifically designed to meet the requirements of light duty truck applications with short, non-frequent operating cycles such as tippers, and small loaders.

The design is very similar to that of the F1 series pumps but is even more compact. It utilizes our well proven 40° and 45° concepts with spherical pistons and laminated piston rings, offering high volumetric and mechanical efficiencies and, thanks also to the small number of parts, unprecedented reliability.

- Input power to 71 kW
- Shaft speed to 2300 rpm
- Operating pressure to 350 bar
- High overall efficiency
- Low weight
- Small installed envelope
- Proven reliability
- Easy servicing

The T1, with shaft and mounting flange configuration conforming to the European standard, can be installed on most European truck gearboxes. Suitable power-take-offs are also available from Parker Hannifin.

**See page 26**

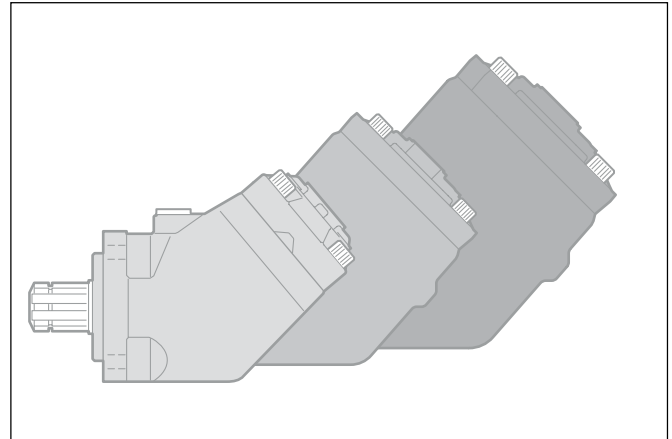

### Typical T1 applications

- Front end tippers
- Under boddy tippers
- Light and low frequent used “ hydraulic circuit “

## VP1 Pump

The VP1 is the world's first variable displacement pump for truck applications. It can be close-coupled to a gearbox PTO (power take-off) or to a coupling independent PTO (e.g. an engine PTO) which meets ISO standard 7653-1985.

An application that makes full use of all the features of the VP1 is truck cranes with a load sensing system. The complex systems of refuse collection vehicles and sewage trucks as well as various combinations of tippers, cranes, snow ploughs, and salt/sand spreaders can also be greatly simplified and optimized with the VP1 pump.

The VP1 provides the hydraulic system with the correct amount of fluid at precisely the right moment, effectively reducing energy consumption and heat generation. This means a smoother and quieter running system with much reduced impact on the environment. The VP1 is highly efficient, has a small installation envelop and is extremely light. It is reliable, economical and easy to install.

### Design

#### Large angle - compact design

The pump design permits a large angle, 20°, between piston and slipper shoe/swashplate, providing compactness and small outer dimensions.

#### Tandem coupling

The through-shaft permits tandem coupling of an additional pump, such as a series F1 fixed displacement pump.

#### Accepts high external shaft loads

Heavy duty roller bearings allow radial loads on the VP1 shaft end which makes it possible to install a gear directly on the shaft without additional bearings.

#### Long life

The VP1 is designed for trucks with hydraulic load sensing systems. It is sturdy, yet simple, with few moving parts. The result is a reliable pump with long service life.

See page 30



The two frame sizes, VP1-45 and -75, have the same, small installation dimensions. Shaft and mounting flange follow the European ISO standard 7653-1985. The VP1 is suitable for all load sensing systems, regardless of make.

### Features

- Variable displacement
- Low noise level
- High power-to-weight ratio
- Compact and light
- Highly efficient
- Sturdy design
- Withstands low temperatures
- Reliable and easy to service
- Can be close coupled and tandem mounted.

### High overall efficiency

Uniquely designed parts like the piston/slipper shoe and 'floating' valve plate minimize mechanical losses. The valve plate, which floats on five pistons, contributes to a quiet running pump with low internal leakage and high volumetric efficiency.

### Retainer plate

The retainer plate (refer to the cut-away illustration on page 31) is of a heavy duty design which makes the pump withstand high shaft speeds and fast speed changes.



## Accessories

### Adaptor kits and accessories for F1, F2, T1 and VP1 pumps

#### BLA

Boost unit.  
See chapter 8.

#### Fittings

Suction fittings and fitting kits  
See chapter 9.

#### Bypass valve

BPV-F1/-T1, BPV-F1-25 and 81, BPV-F2, BPV-VP1, BPV-L.

See chapter 10.

#### Unloading valve

ES line mounted unloading valve.  
See chapter 10.

#### Torque limiting valve

MB-F2-H1  
See chapter 10.

#### Electrical connector

Electrical connector assembly  
See chapter 10.

#### Accessories

Universal PTO air valve kits, PTO adapter kits for engines, cardan shafts, pump couplings and mounting brackets, return filter and filter indicator, air breather filter and splitter boxes (SB 1-1,18, 1-1,54)

See chapter 11.

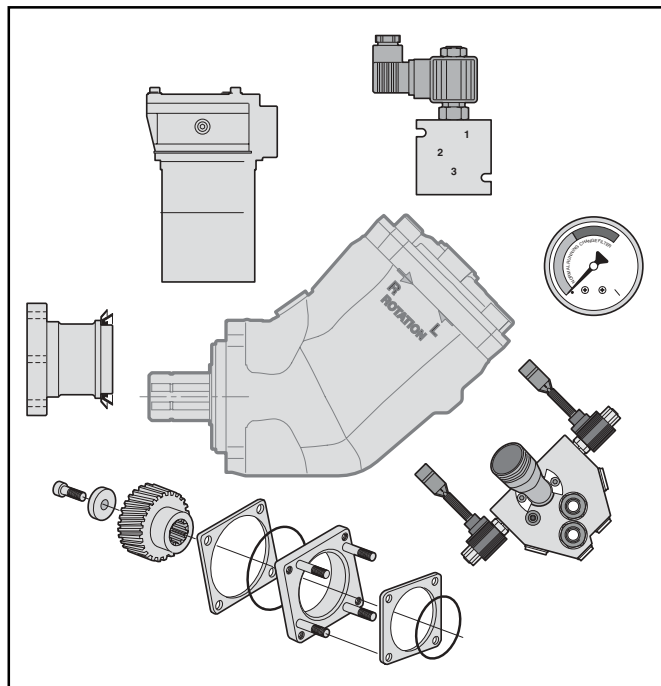

# Pump and Line selection

Installation guidelines for  
F1, F2, T1  
and VP1 pumps

| Contents               | Page |
|------------------------|------|
| <b>Pump selection:</b> |      |
| F1 and T1 .....        | 11   |
| <b>Line selection</b>  |      |
| All pumps .....        | 12   |
| Nomogram .....         | 13   |

## Pump selection

### F1 and T1

The following table shows pump flow at selected PTO gear ratios and engine rpm's.

| PTO gear ratio | Engine speed [rpm] | Pump flow [l/min] |       |       |       |       |        |        |
|----------------|--------------------|-------------------|-------|-------|-------|-------|--------|--------|
|                |                    | F1-25             | F1-41 | T1-51 | F1-61 | T1-81 | F1-101 | T1 121 |
| 1:0.8          | 800                | 16                | 26    | 33    | 38    | 52    | 66     | 76     |
|                | 900                | 18                | 29    | 37    | 43    | 59    | 74     | 85     |
|                | 1000               | 20                | 33    | 41    | 48    | 65    | 82     | 95     |
|                | 1100               | 23                | 36    | 45    | 52    | 72    | 91     | 104    |
|                | 1200               | 25                | 39    | 49    | 57    | 78    | 99     | 114    |
| 1:1.0          | 800                | 20                | 33    | 41    | 48    | 65    | 82     | 95     |
|                | 900                | 23                | 37    | 46    | 54    | 73    | 93     | 107    |
|                | 1000               | 26                | 41    | 51    | 60    | 82    | 103    | 119    |
|                | 1100               | 28                | 45    | 56    | 65    | 90    | 113    | 130    |
|                | 1200               | 31                | 49    | 61    | 71    | 98    | 123    | 142    |
| 1.1.25         | 800                | 26                | 41    | 51    | 60    | 82    | 103    | 119    |
|                | 900                | 29                | 46    | 57    | 67    | 92    | 116    | 133    |
|                | 1000               | 32                | 51    | 64    | 74    | 102   | 129    | 148    |
|                | 1100               | 35                | 56    | 70    | 82    | 111   | 141    | 163    |
|                | 1200               | 38                | 61    | 77    | 89    | 122   | 154    | 178    |
| 1:1.5          | 800                | 31                | 49    | 61    | 71    | 98    | 123    | 142    |
|                | 900                | 35                | 55    | 69    | 80    | 110   | 139    | 160    |
|                | 1000               | 38                | 61    | 77    | 90    | 122   | 154    | 178    |
|                | 1100               | 42                | 67    | 84    | 98    | 135   | 170    | 196    |
|                | 1200               | 46                | 74    | 92    | 107   | 147   | 185    | 213    |

#### NOTE:

- Make sure max torque and bending moment (due to the weight of the pump) of the utilized PTO are not exceeded. (The approx. center of gravity of the various pump sizes are shown in the installation drawings).
- Make sure max allowed output torque from the PTO is not exceeded.
- Contact Parker Hannifin if the inlet (suction) pressure is believed to be less than 1.0 bar (absolute); insufficient inlet pressure can cause noise and pump damage because of cavitation.

#### Flow and torque formulas (no regard to efficiency)

$$\text{Flow: } Q = \frac{D \times n}{1000} \text{ [l/min]}$$

where: D is pump displacement [cm<sup>3</sup>/rev]  
n is shaft speed [rpm]

$$\text{Torque: } M = \frac{D \times p}{63} \text{ [Nm]}$$

where: D is pump displacement [cm<sup>3</sup>/rev]  
p is utilized pressure [bar]

A suitable pump size for a truck application can be selected as follows:

**Operating conditions**

As an example, a cargo crane specifies:

- Flow: 60-80 l/min
- Pressure: 230 bar
- Diesel engine speed  $\approx$  800 rpm

**Determine pump speed**

A Volvo type BKUH 1123 PTO on gearbox SR 1700, for example, has a gear ratio of 1:1.54.

The pump speed will be:

- $800 \times 1.54 \approx 1200$  rpm

**Select a suitable pump size**

Use diagram 1 and select a pump that will provide 60 - 80 l/min at 1200 rpm.

Follow line 'a' (1200 rpm) until it crosses line 'b' (70 l/min).

- F1-61 is a suitable choice

**Required input torque**

Make sure the PTO and the gear-box tolerates the pump torque. Use diagram 2 to obtain the required pump torque.

Follow a line from 'c' (230 bar) until it crosses the F1-60 line (the selected pump).

- Read 220 Nm (at 'd')

**NOTE:** A rule-of-thumb is to select the highest PTO ratio and the smallest pump size that meets the crane specification without exceeding the pump speed, pressure, and power limitations.

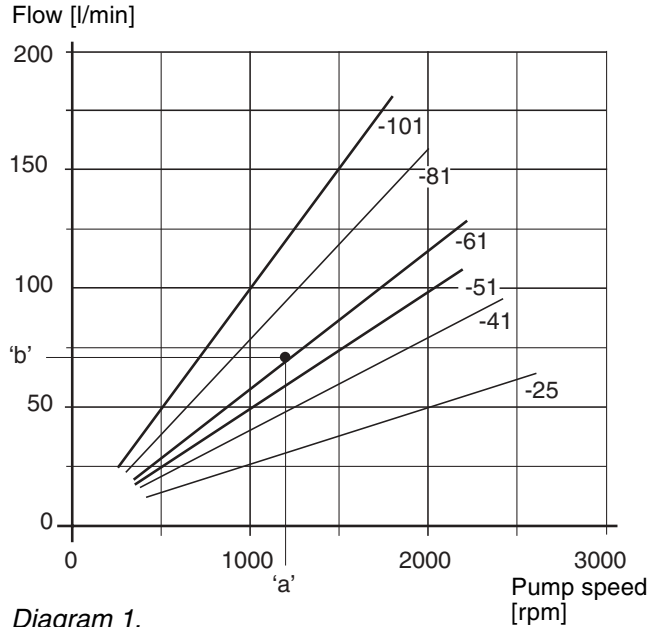

Diagram 1.

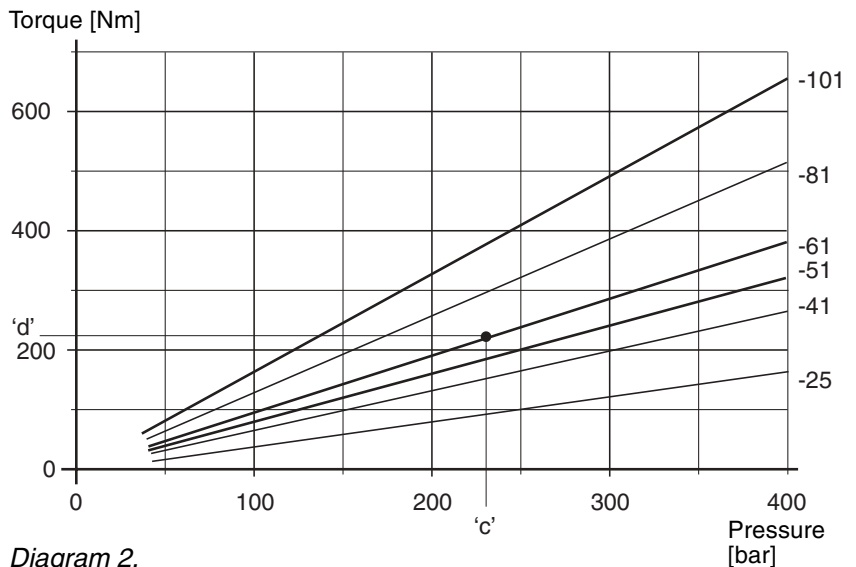

Diagram 2.

**Line selection  
 all pumps**

| Line type         | Flow velocity [m/s] |
|-------------------|---------------------|
| Inlet (suction)   | max 1.0             |
| Outlet (pressure) | max 5.0             |

| Flow rate [l/min] | Flow velocity [m/s] at selected line sizes [mm/inches] |         |             |             |         |             |
|-------------------|--|---------|-------------|-------------|---------|-------------|
|                   | 19 / 3/4"  | 25 / 1" | 32 / 1 1/4" | 38 / 1 1/2" | 51 / 2" | 64 / 2 1/2" |
| 25                | 1.5  | 0.8     | 0.5         | 0.4         | 0.2     | 0.1         |
| 50                | 2.9  | 1.7     | 1.0         | 0.7         | 0.4     | 0.3         |
| 75                | 4.4  | 2.5     | 1.6         | 1.1         | 0.6     | 0.4         |
| 100               | (5.9)  | 3.4     | 2.1         | 1.5         | 0.8     | 0.5         |
| 150               | (8.8)  | (5.1)   | 3.1         | 2.2         | 1.3     | (0.8)       |
| 200               | -  | -       | 4.1         | 2.9         | 1.6     | 1.0         |

Table 1. Outlet (pressure) line

In order to obtain sufficient inlet (suction) pressure to the pump, low noise level and low heat generation, flow speeds shown in table 2, right, should not be exceeded.

From table 1 (page 12), select the smallest line dimension that meets the flow speed recommendation; example:

- At 100 l/min, a 50 mm suction line and a 25 mm pressure line is needed.

**NOTE:** Long inlet (suction) lines, low inlet pressure (caused by e.g. a reservoir positioned below the pump) and/or low temperatures may require larger line dimensions.

Alternatively, the pump speed will have to be lowered to avoid pump cavitation (which may cause noise, deteriorating performance and pump damage).



| Line type         | Flow velocity [m/s] |
|-------------------|---------------------|
| Inlet (suction)   | max 1.0             |
| Outlet (pressure) | max 5.0             |

**Nomogram**

Flow - Line dimension - Flow velocity

Table 2.

Example 1  
 Pressure line  
 Q = 65 l/min  
 d = 3/4"  
 v = 3.8 m/s

Example 2  
 Suction line  
 Q = 50 l/min  
 v = 0.8  
 d = 1 1/2"

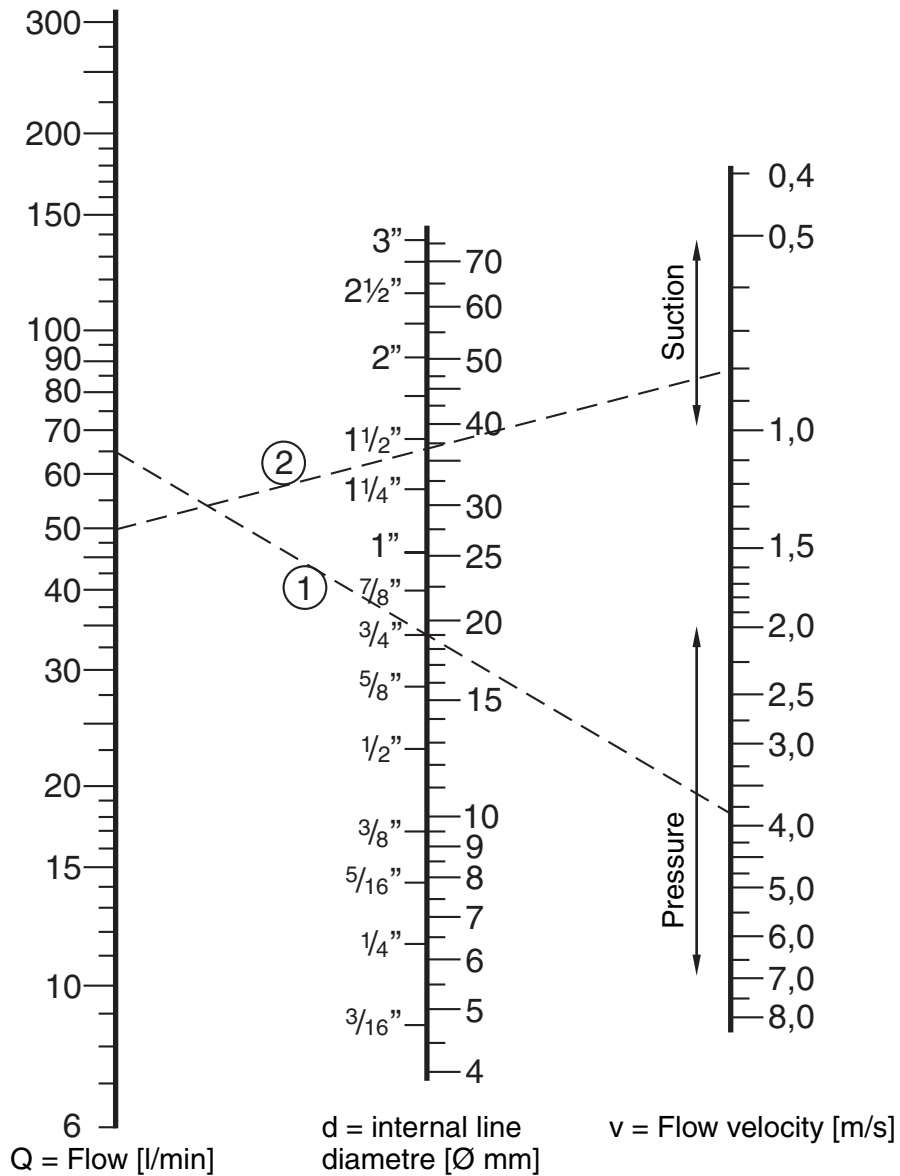

# F1 Pump

## F1-ISO



| Content   | Page | Chapter |
|---|------|---------|
| Pump and line selection .....                         | 10   | 2       |
| Specifications .....                                  | 15   |         |
| Pump cross section .....                              | 15   |         |
| Installation dimensions F1-25, -41, -51 and -61 ..... | 16   |         |
| Ordering code .....                                   | 16   |         |
| Standard versions .....                               | 16   |         |
| Installation dimensions F1-81 and -101 .....          | 17   |         |
| Port size .....                                       | 17   |         |
| Suction fittings .....                                | 37   | 9       |
| Installation and start-up .....                       | 60   | 12      |

**Specifications**

| F1 frame size                              | 25   | 41   | 51   | 61   | 81                 | 101                |
|--|------|------|------|------|--------------------|--------------------|
| <b>Displacement</b> [cm <sup>3</sup> /rev] | 25.6 | 40.9 | 51.1 | 59.5 | 81.6               | 102.9              |
| <b>Max flow</b> <sup>1)</sup> [l/min]      |      |      |      |      |                    |                    |
| at 350 bar                                 | 67   | 98   | 112  | 131  | 163 <sup>3)</sup>  | 185 <sup>3)</sup>  |
| at 400 bar                                 | 56   | 86   | 97   | 113  | 143                | 160                |
| <b>Max operating pressure</b> [bar]        |      |      |      |      |                    |                    |
| continuous                                 | 350  |      |      |      |                    | 350                |
| intermittent                               | 400  |      |      |      |                    | 400                |
| <b>Shaft speed</b> [rpm]                   |      |      |      |      |                    |                    |
| - short circuited pump (low press.)        | 2700 | 2700 | 2700 | 2700 | 2300               | 2300               |
| - max speed at 350 bar <sup>2)</sup>       | 2600 | 2400 | 2200 | 2200 | 2000 <sup>3)</sup> | 1800 <sup>3)</sup> |
| at 400 bar <sup>2)</sup>                   | 2200 | 2100 | 1900 | 1900 | 1750               | 1550 <sup>3)</sup> |
| <b>Torque</b> <sup>1)</sup> [Nm]           |      |      |      |      |                    |                    |
| at 350 bar                                 | 142  | 227  | 284  | 331  | 453                | 572                |
| at 400 bar                                 | 163  | 260  | 324  | 378  | 518                | 653                |
| <b>Input power</b> [kW]                    |      |      |      |      |                    |                    |
| - continuous                               | 31   | 46   | 52   | 61   | 76                 | 86                 |
| - intermittent <sup>4)</sup>               | 39   | 57   | 66   | 76   | 95                 | 108                |
| <b>Weight</b> [kg]                         | 8.5  | 8.5  | 8.5  | 8.5  | 12.5               | 12.5               |

- 1) Theoretical values
- 2) Valid at an inlet pressure of 1.0 bar (abs.) when operating on mineral oil at a viscosity of 30 mm<sup>2</sup>/s (cSt).
- 3) Valid with 2<sup>1</sup>/<sub>2</sub>" inlet (suction) line.  
 With 2" suction line: F1-81 – max 1400 rpm (Q≈120 l/min);  
 F1-101 – max 1000 rpm (Q≈120 l/min).
- 4) Max 6 seconds in any one minute.

**NOTE:** For noise level information, contact Parker Hannifin (Mobile Controls Div.).

**Pump cross section**

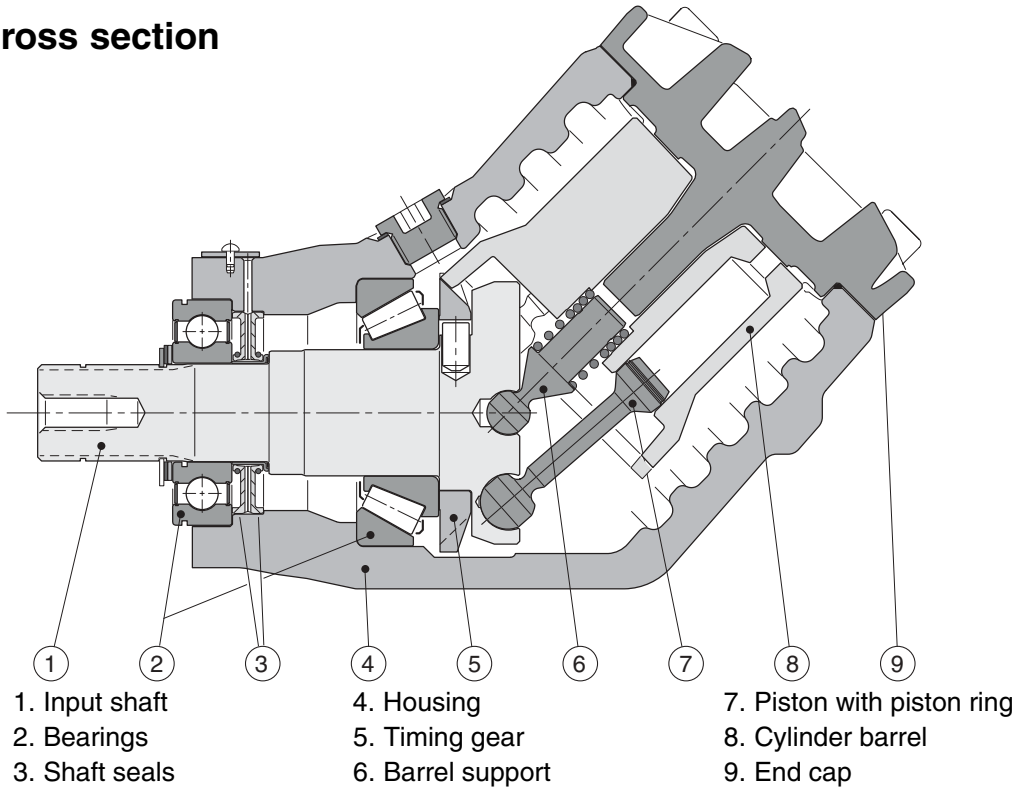

- 1. Input shaft
- 2. Bearings
- 3. Shaft seals
- 4. Housing
- 5. Timing gear
- 6. Barrel support
- 7. Piston with piston ring
- 8. Cylinder barrel
- 9. End cap

**Installation dimensions, F1-25, -41, -51 and -61**

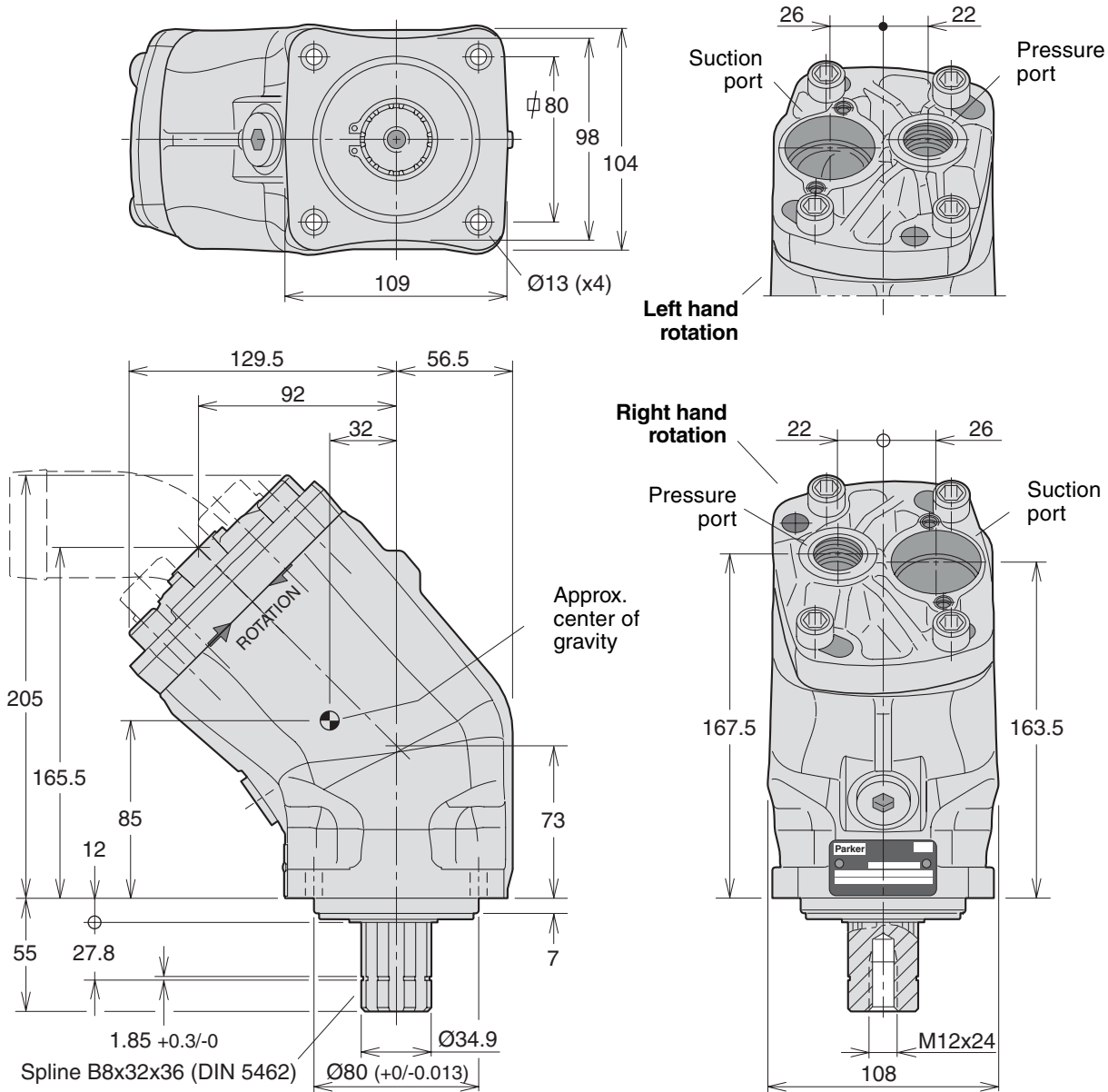

**Ordering code**

Example: **F1- 81 - R**

F1 frame size  
**25, 41, 51, 61, 81 or 101**

Shaft rotation  
**R** Right hand  
**L** Left hand

**Standard versions**

| Designation | Ordering no. |
|-------------|--------------|
| F1-25-R     | 378 1024     |
| -L          | 378 1025     |
| F1-41-R     | 378 1040     |
| -L          | 378 1041     |
| F1-51-R     | 378 1050     |
| -L          | 378 1051     |
| F1-61-R     | 378 1060     |
| -L          | 378 1061     |

**NOTE:** The F1 pump **does not** include a suction fitting; it must be ordered separately. See chapter 9.



**Installation dimensions, F1-81 and -101**

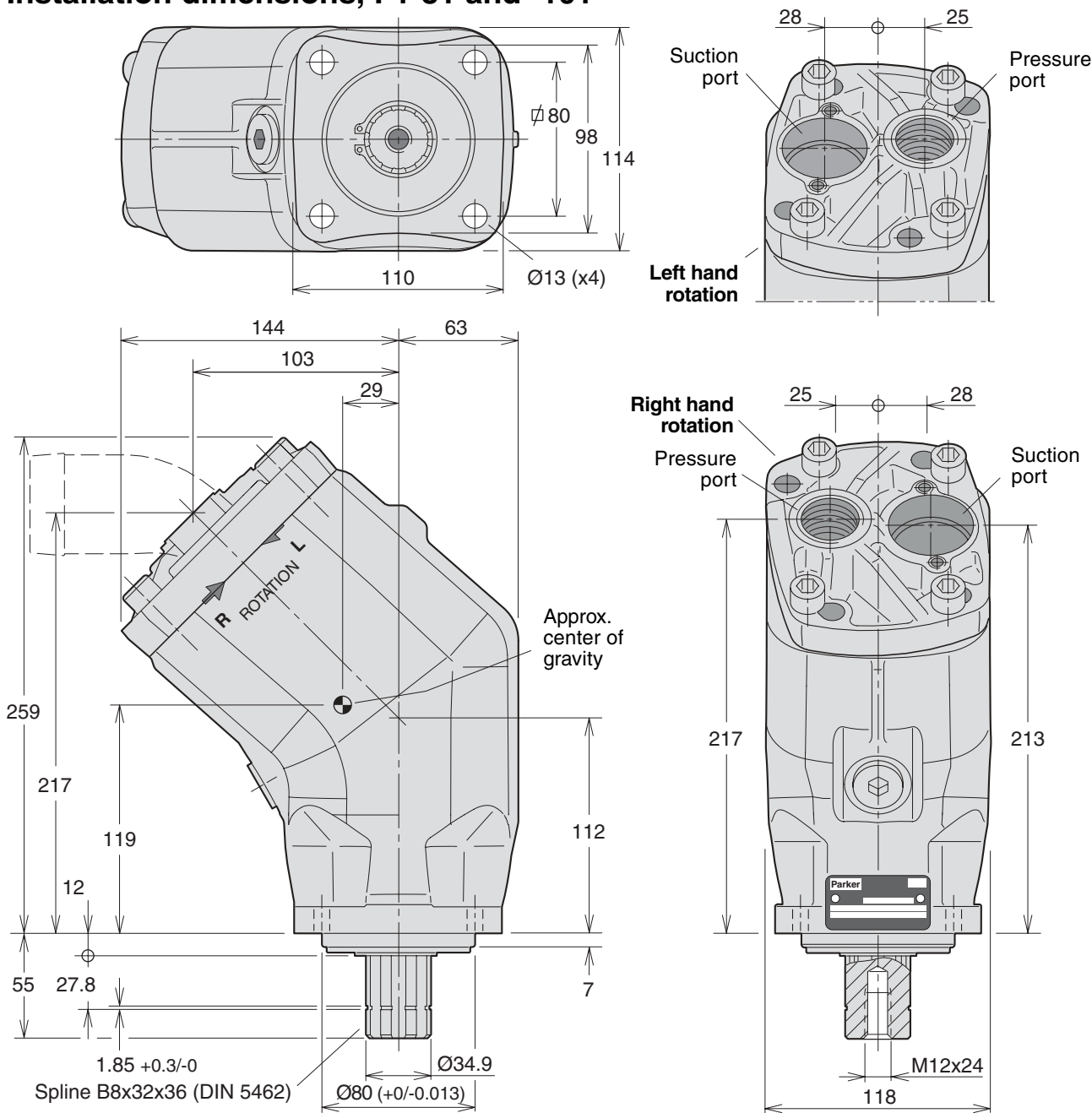

**Port size**

| F1 frame size | Pressure port <sup>1)</sup> |
|---------------|-----------------------------|
| -25           | 3/4"                        |
| -41           | 3/4"                        |
| -51           | 3/4"                        |
| -61           | 3/4"                        |
| -81           | 1"                          |
| -101          | 1"                          |

**Standard versions**

| Designation | Ordering no. |
|-------------|--------------|
| F1-81-R     | 378 1080     |
| -L          | 378 1081     |
| F1-101-R    | 378 1100     |
| -L          | 378 1101     |

**NOTE:** The F1 pump **does not** include a suction fitting; it must be ordered separately. See chapter 9.

# F1 Pump

## F1-SAE



| Content                         | Page | Chapter |
|---------------------------------|------|---------|
| Pump and line selection .....   | 10   | 2       |
| Specifications .....            | 19   |         |
| Pump cross section .....        | 19   |         |
| Installation dimensions .....   | 20   |         |
| Ordering code (SAE) .....       | 20   |         |
| Port size .....                 | 20   |         |
| Standard SAE versions .....     | 20   |         |
| Suction fittings .....          | 37   | 9       |
| Installation and start-up ..... | 60   | 12      |

## Specifications

| F1 frame size  | 25                 | 41           | 51           | 61           |
|--|--------------------|--------------|--------------|--------------|
| <b>Displacement</b> [cm <sup>3</sup> /rev]<br>[cu in/rev]    | 25.6<br>1.56       | 40.9<br>2.50 | 51.1<br>3.12 | 59.5<br>3.63 |
| <b>Max flow</b> <sup>1)</sup>                                |                    |              |              |              |
| at 350 bar [l/min]   | 67                 | 98           | 112          | 131          |
| at 5000 psi [gpm]  | 17.7               | 25.9         | 29.6         | 34.6         |
| at 400 bar [l/min]   | 56                 | 86           | 97           | 113          |
| at 5000 psi [gpm]  | 14.8               | 22.7         | 25.6         | 29.8         |
| <b>Max operating pressure</b>                                |                    |              |              |              |
| continuous [bar]/ [psi]                                      | ———— 350/5000 ———— |              |              |              |
| intermittent [bar]/ [psi]                                    | ———— 400/5800 ———— |              |              |              |
| <b>Shaft speed</b> [rpm]                                     |                    |              |              |              |
| - short circuited pump (low press.)                          | 2700               | 2700         | 2700         | 2700         |
| - max speed at 350 bar <sup>2)</sup> /5000 psi <sup>2)</sup> | 2600               | 2400         | 2200         | 2200         |
| at 400 bar <sup>2)</sup> /5800 psi <sup>2)</sup>             | 2200               | 2100         | 1900         | 1900         |
| <b>Torque</b> <sup>1)</sup>                                  |                    |              |              |              |
| at 350 bar [Nm]  | 142                | 227          | 284          | 331          |
| at 5000 psi [lbf ft]   | 105                | 168          | 210          | 244          |
| at 400 bar [Nm]  | 163                | 260          | 324          | 378          |
| at 5800 psi [lbf ft]   | 120                | 192          | 239          | 279          |
| <b>Input power</b>   |                    |              |              |              |
| - continuous [kW]  | 31                 | 46           | 52           | 61           |
| [hp]   | 42                 | 62           | 70           | 82           |
| - intermittent [kW] <sup>3)</sup>                            | 39                 | 57           | 66           | 76           |
| [hp] <sup>3)</sup>   | 52                 | 76           | 88           | 102          |
| <b>Weight</b> [kg]   | 8.5                | 8.5          | 8.5          | 8.5          |
| [lbs]  | 18.7               | 18.7         | 18.7         | 18.7         |

- 1) Theoretical values
- 2) Valid at an inlet pressure of 1.0 bar/15 psi (abs.) when operating on mineral oil at a viscosity of 30 mm<sup>2</sup>/s (cSt)/150 SUS.
- 3) Max 6 seconds in any one minute.

**NOTE:** For noise level information, contact Parker Hannifin.

## Pump cross section

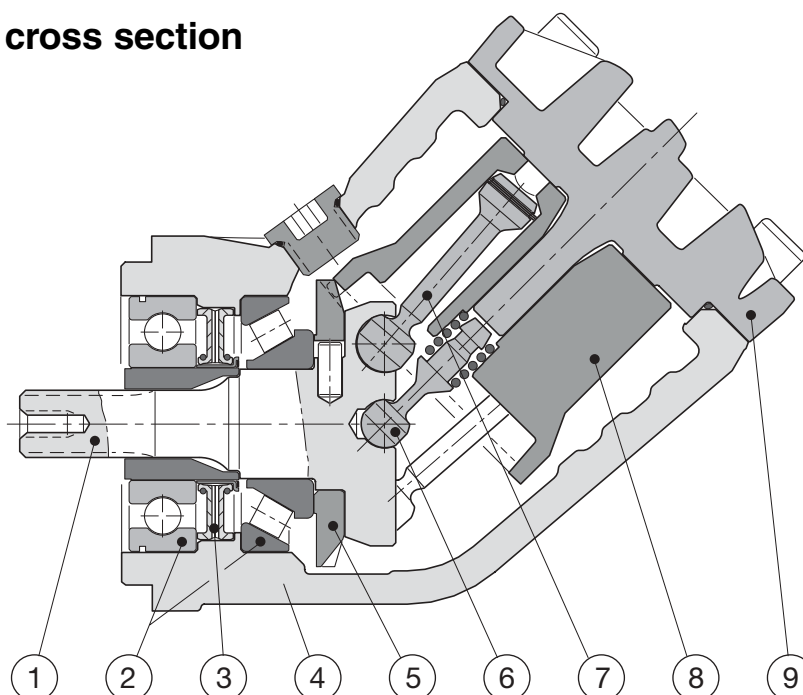

1. Input shaft
2. Bearings
3. Shaft seal
4. Housing
5. Timing gear
6. Barrel support
7. Piston with piston ring
8. Cylinder barrel
9. End cap

### Installation dimensions, F1-25, -41, -51 and -61 (SAE)

Dimensions in mm (inches)

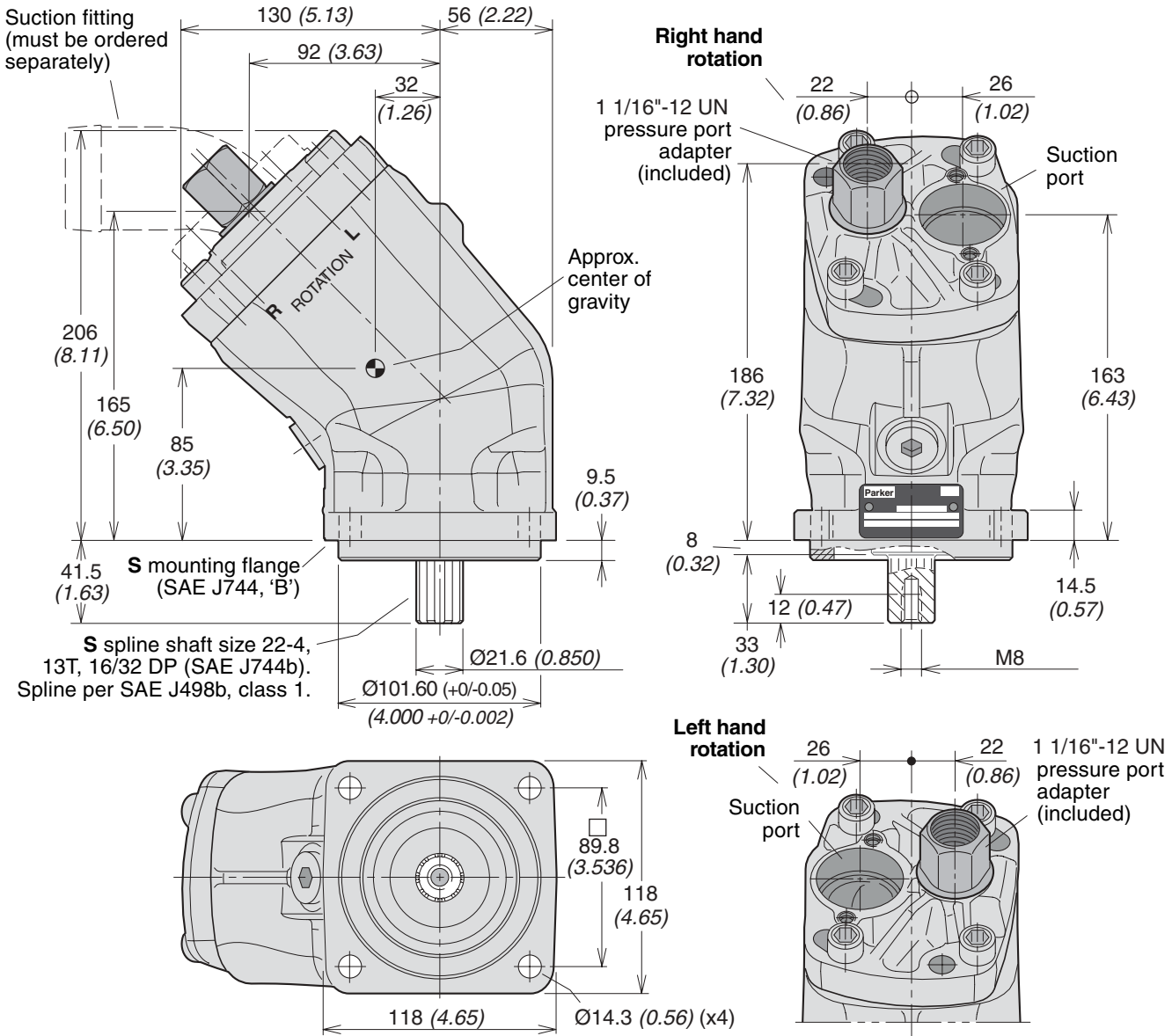

**NOTE:** The F1 pump **does not** include a suction fitting; it must be ordered separately. See chapter 9.

# F1 Motor



4

| Content                         | Page | Chapter |
|---------------------------------|------|---------|
| Motor and line selection .....  | 10   | 2       |
| Specifications .....            | 22   |         |
| Ordering code .....             | 22   |         |
| Port size .....                 | 22   |         |
| Standard versions .....         | 22   |         |
| Installation dimensions .....   | 22   |         |
| Suction fittings .....          | 37   | 9       |
| Installation and start-up ..... | 60   | 12      |

### Specifications

| Motor frame size                           | F1-25-M | F1-41-M | F1-51-M | F1-61-M | F1-81-M | F1-101-M |
|--|---------|---------|---------|---------|---------|----------|
| <b>Displacement</b> [cm <sup>3</sup> /rev] | 25.6    | 40.9    | 51.1    | 59.5    | 81.6    | 102.9    |
| <b>Max operating pressure</b> [bar]        |         |         |         |         |         |          |
| - continuous                               | 250     |         | 250     |         | 250     |          |
| - intermittent                             | 350     |         | 350     |         | 350     |          |
| <b>Max shaft speed</b> [rpm]               |         |         |         |         |         |          |
| - continuous                               | 2 300   | 2 000   | 1 800   | 1 700   | 1 500   | 1 400    |
| - intermittent                             | 3 000   | 2 700   | 2 400   | 2 200   | 2 000   | 1 800    |
| <b>Torque</b> (theor.) [Nm]                |         |         |         |         |         |          |
| - at 200 bar                               | 81      | 130     | 162     | 189     | 259     | 327      |
| - at 350 bar                               | 142     | 227     | 284     | 331     | 453     | 572      |
| <b>Max output power</b> [kW]               |         |         |         |         |         |          |
| - continuous                               | 20      | 27      | 31      | 34      | 41      | 48       |
| - intermittent                             | 26      | 37      | 41      | 44      | 54      | 62       |
| <b>Weight</b> [kg]                         | 8.5     | 8.5     | 8.5     | 8.5     | 12.5    | 12.5     |

### Ordering code

Example: **F1 - 81 - M**  
 F1 Motor frame size **25, 41, 51, 61, 81 or 101**

### Port size

F1 motor frame size **F1-25/41/51/61 -81/101**  
 Port size **3/4" 1"**

### Standard versions

| Designation | Ordering no. |
|-------------|--------------|
| F1-25-M     | 378 1724     |
| -41-M       | 378 1740     |
| -51-M       | 378 1750     |
| -61-M       | 378 1760     |
| -81-M       | 378 1780     |
| -101-M      | 378 1800     |

### Installation dimensions

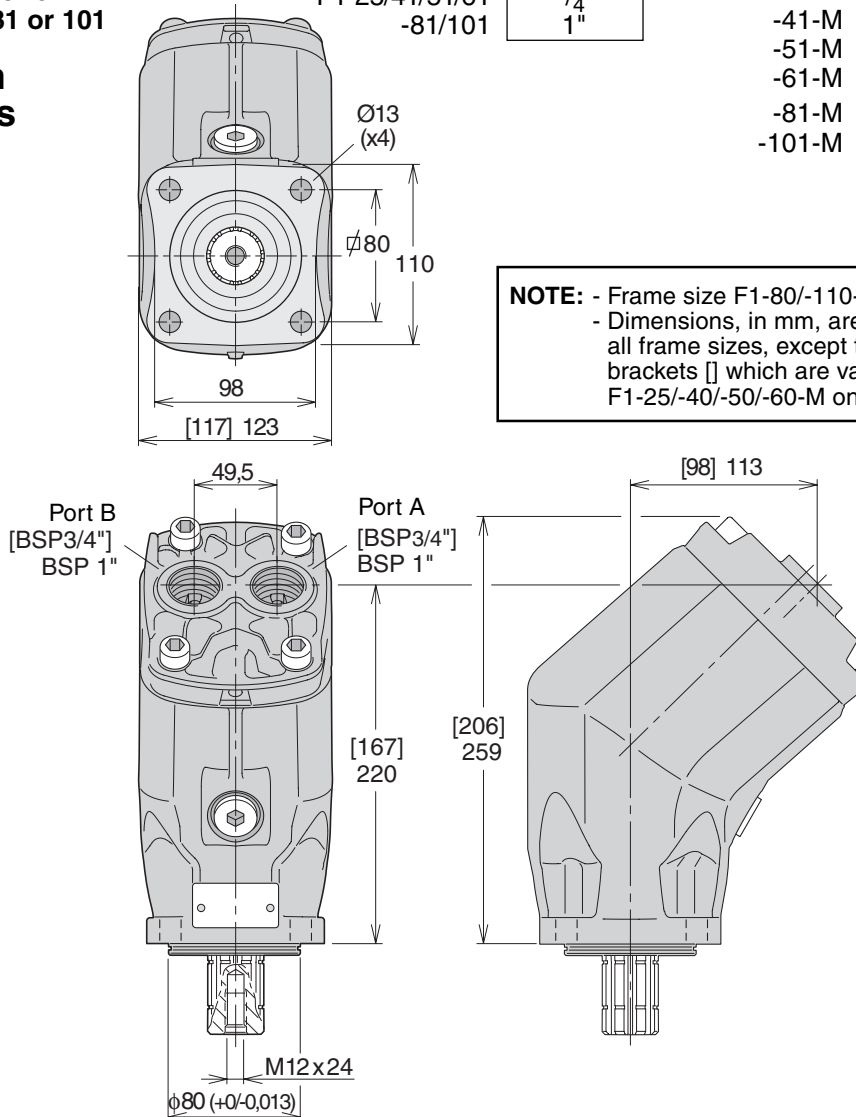

**NOTE:** - Frame size F1-80/-110-M shown.  
 - Dimensions, in mm, are valid for all frame sizes, except those in brackets [ ] which are valid for F1-25/-40/-50/-60-M only.

# F2 Twin-flow Pump



5

| Content                         | Page | Chapter |
|---------------------------------|------|---------|
| Pump and line selection .....   | 10   | 2       |
| Specifications .....            | 24   |         |
| Installation dimensions .....   | 25   |         |
| Ordering code .....             | 25   |         |
| Standard versions .....         | 25   |         |
| Suction fittings .....          | 37   | 9       |
| Installation and start-up ..... | 60   | 12      |

## Specifications

| Frame size  | F2-53/53 | F2-70/35 |
|---|----------|----------|
| <b>Displacement</b> [cm <sup>3</sup> /rev]  |          |          |
| Port A  | 54       | 69       |
| Port B  | 52       | 36       |
| <b>Max operating pressure</b> [bar]   | 350      | 350      |
| <b>Max shaft speed</b> [rpm]<br>(unloaded pump; low pressure)                                   | 2550     | 2550     |
| <b>Max selfpriming speed</b> [rpm]<br>Ports A <sup>1)2)</sup> and B <sup>1)2)</sup> pressurized | 1800     | 1800     |
| Port A <sup>2)</sup> unloaded, pressure in port B   | 2100     | 2100     |
| <b>Input power</b> [kW]   |          |          |
| Max intermittent <sup>3)</sup>  | 110      | 110      |
| Max continuous  | 88       | 88       |
| <b>Weight</b> [kg]  | 19       | 19       |

- 1) Valid with 2 1/2" inlet (suction) line; with 2" inlet line: max 1400 rpm.  
 2) Measured at 1.0 bar abs. inlet pressure.  
**Please note:** A lower inlet pressure affects pump performance.  
 3) Max 6 seconds in any one minute.

### 'Left hand' and 'right hand' end caps

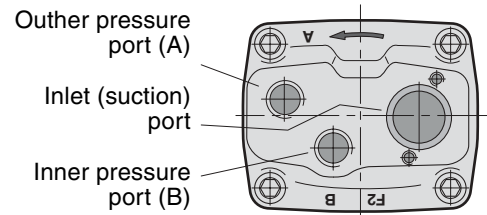

*End cap for right hand rotating pump*

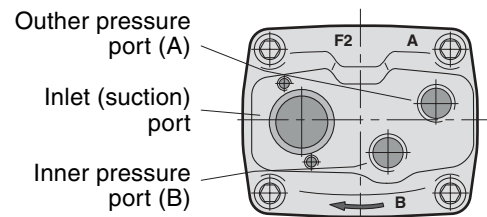

*End cap for left hand rotating pump*

### Flow vs. shaft speed (theoretical)

| Pump speed [rpm]             | 800 | 1000 | 1200 | 1400 | 1600 | 1800 | 1900 | 2000 | 2100 |
|------------------------------|-----|------|------|------|------|------|------|------|------|
| <b>F2-53/53 flow</b> [l/min] |     |      |      |      |      |      |      |      |      |
| Port A                       | 43  | 54   | 65   | 76   | 86   | 97   | -    | -    | -    |
| Port B                       | 42  | 52   | 62   | 73   | 83   | 94   | 99   | 104  | 109  |
| Total (ports A + B)          | 85  | 106  | 127  | 149  | 169  | 191  | -    | -    | -    |
| <b>F2-70/35 flow</b> [l/min] |     |      |      |      |      |      |      |      |      |
| Port A                       | 55  | 69   | 83   | 97   | 110  | 124  | -    | -    | -    |
| Port B                       | 29  | 36   | 43   | 50   | 58   | 65   | 68   | 72   | 76   |
| Total (ports A + B)          | 84  | 105  | 126  | 147  | 168  | 189  | -    | -    | -    |

### Shaft torque vs. pressure (theoretical)

| Pressure [bar]              | 150 | 200 | 250 | 300 | 350 |
|-----------------------------|-----|-----|-----|-----|-----|
| <b>F2-53/53 torque</b> [Nm] |     |     |     |     |     |
| Port A                      | 126 | 168 | 210 | 252 | 294 |
| Port B                      | 124 | 165 | 206 | 248 | 289 |
| Total (ports A and B)       | 250 | 333 | 416 | 500 | 583 |
| <b>F2-70/35 torque</b> [Nm] |     |     |     |     |     |
| Port A                      | 164 | 219 | 274 | 329 | 383 |
| Port B                      | 86  | 114 | 143 | 171 | 200 |
| Total (ports A and B)       | 250 | 333 | 417 | 500 | 583 |



**Installation dimensions**

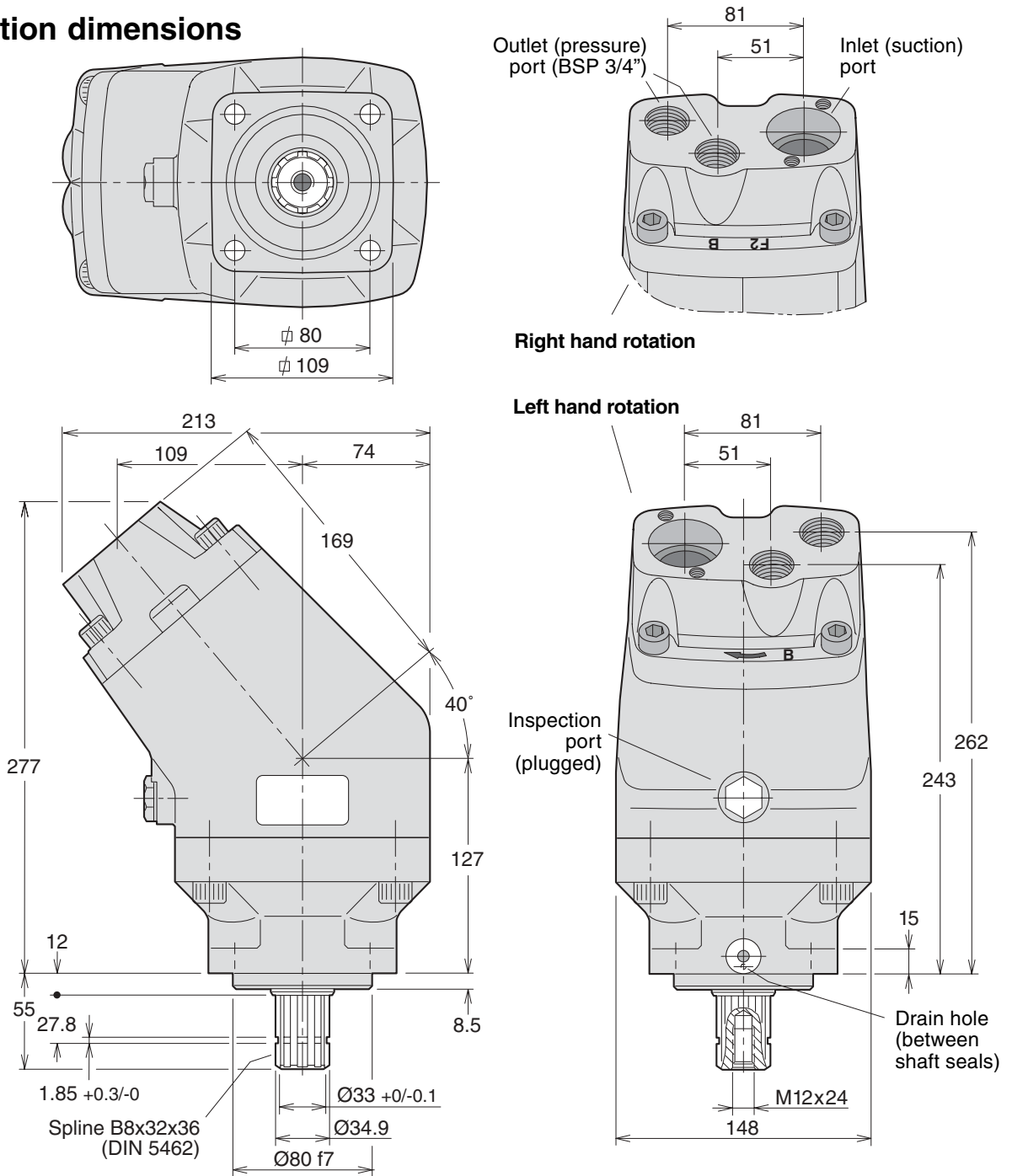

**5**

**Ordering code**

Example: **F2 - 53/53 - L**

Frame size [cm<sup>3</sup>/rev]  
**53/53**  
**70/35**

Direction of rotation  
**L** Left hand  
**R** Right hand

**Standard versions**

| Designation | Ordering no. |
|-------------|--------------|
| F2-53/53-R  | 378 1453     |
| F2-53/53-L  | 378 1454     |
| F2-70/35-R  | 378 1470     |
| F2-70/35-L  | 378 1471     |

**NOTE:**

- Before start-up, tighten the inspection port plug to 70–100 Nm.
- To change the direction of rotation, **the end cap must be replaced.**

**NOTE:** The F2 pump **does not** include a suction fitting; it must be ordered separately. See chapter 9.

# T1 Pump

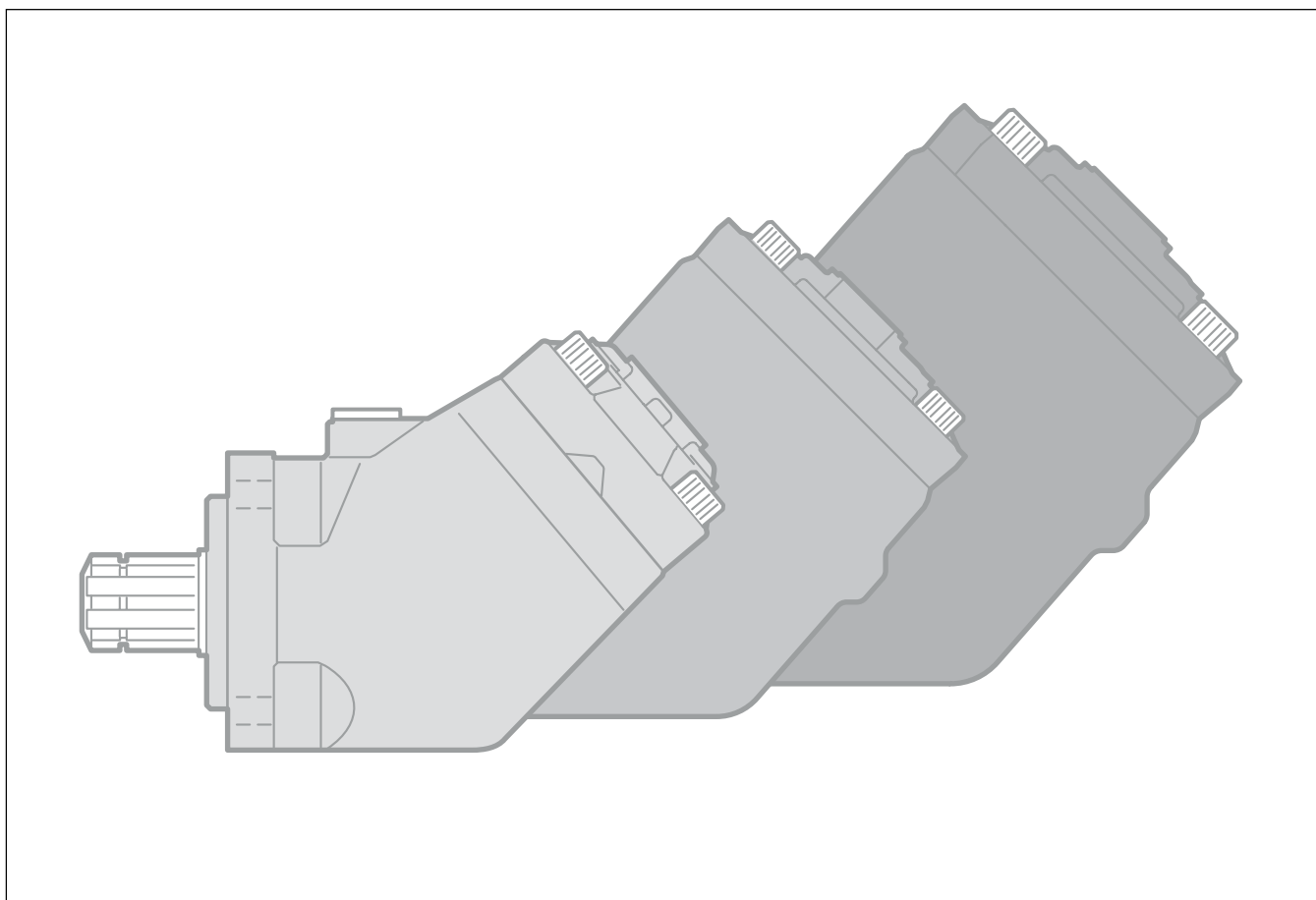

| Content                         | Page  | Chapter |
|---------------------------------|-------|---------|
| Pump and line selection .....   | 10    | 2       |
| Specifications .....            | 27    |         |
| Installation dimensions .....   | 28-29 |         |
| Ordering code .....             | 29    |         |
| Port size .....                 | 29    |         |
| Standard versions .....         | 29    |         |
| Suction fittings .....          | 37    | 9       |
| Installation and start-up ..... | 60    | 12      |

## Specifications

| T1 frame size                              | 51   | 81                 | 121                |
|--|------|--------------------|--------------------|
| <b>Displacement</b> [cm <sup>3</sup> /rev] | 50.0 | 81.5               | 118,5              |
| <b>Max flow</b> <sup>1)</sup> [l/min]      | 80   | 163 <sup>3)</sup>  | 213 <sup>3)</sup>  |
| <b>Max operating pressure</b> [bar]        |      |                    |                    |
| continuous                                 | 200  | —                  | 200                |
| intermittent <sup>4)</sup>                 | 350  | —                  | 350                |
| <b>Shaft speed</b> [rpm]                   |      |                    |                    |
| short circuited pump (low press.)          | 2300 | 2300               | 2300               |
| max speed <sup>2)</sup>                    | 2100 | 2000 <sup>3)</sup> | 1600 <sup>3)</sup> |
| <b>Torque</b> <sup>1)</sup> [Nm]           |      |                    |                    |
| at 200 bar                                 | 158  | 258                | 376                |
| at 350 bar                                 | 278  | 453                | 658                |
| <b>Input power</b> [kW]                    |      |                    |                    |
| continuous                                 | 27   | 54                 | 71                 |
| intermittent <sup>4)</sup>                 | 34   | 67                 | 89                 |
| <b>Weight</b> [kg]                         | 7.2  | 8.5                | 12.5               |

- 1) Theoretical values
- 2) Valid at an inlet pressure of 1.0 bar (abs.) when operating on mineral oil at a viscosity of 30 mm<sup>2</sup>/s (cSt).
- 3) Valid with 2 1/2" inlet (suction) line. With 2" suction line:  
 T1-81 – max 1400 rpm (Q ≈ 120 l/min);  
 T1-121 – max 950 rpm (Q ≈ 120 l/min).
- 4) Max 6 seconds in any one minute.

**NOTE:**  
 For noise level information, contact Parker Hannifin.

## Pump cross section

(T1-51 shown)

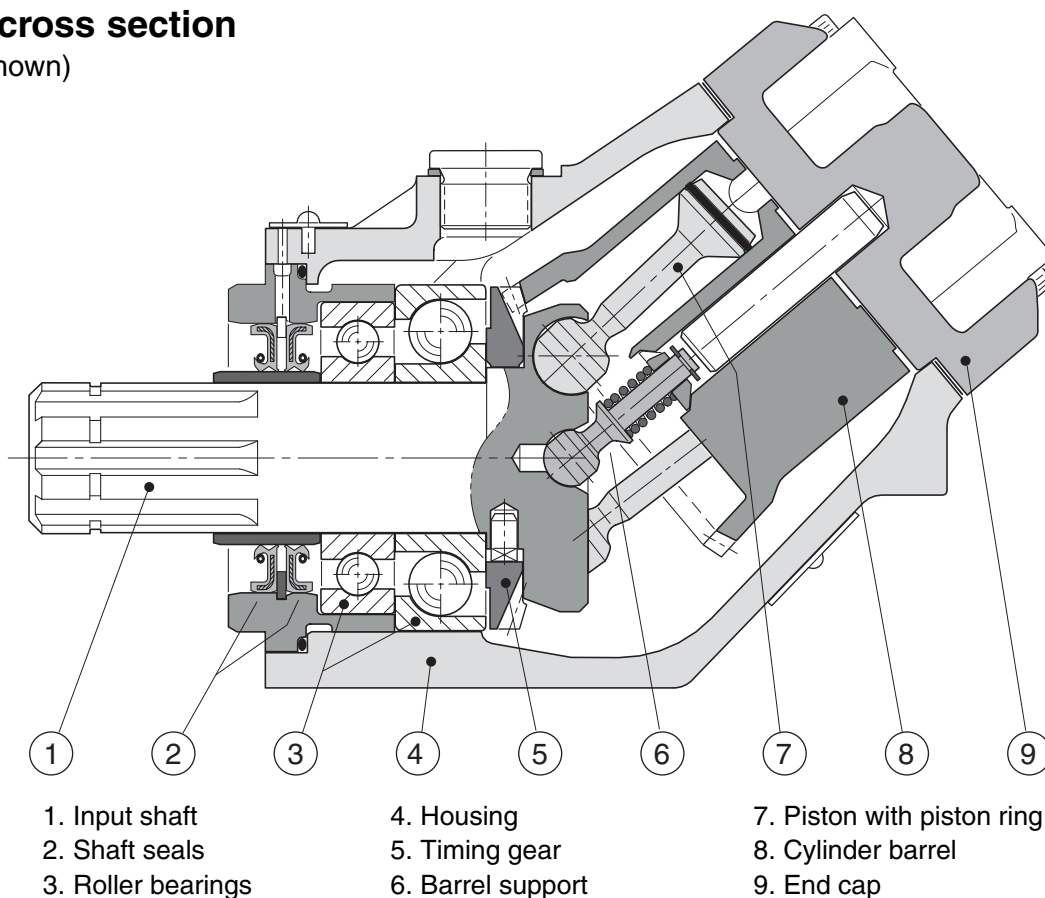

- 1. Input shaft
- 2. Shaft seals
- 3. Roller bearings
- 4. Housing
- 5. Timing gear
- 6. Barrel support
- 7. Piston with piston ring
- 8. Cylinder barrel
- 9. End cap

**Installation dimensions, T1-51**

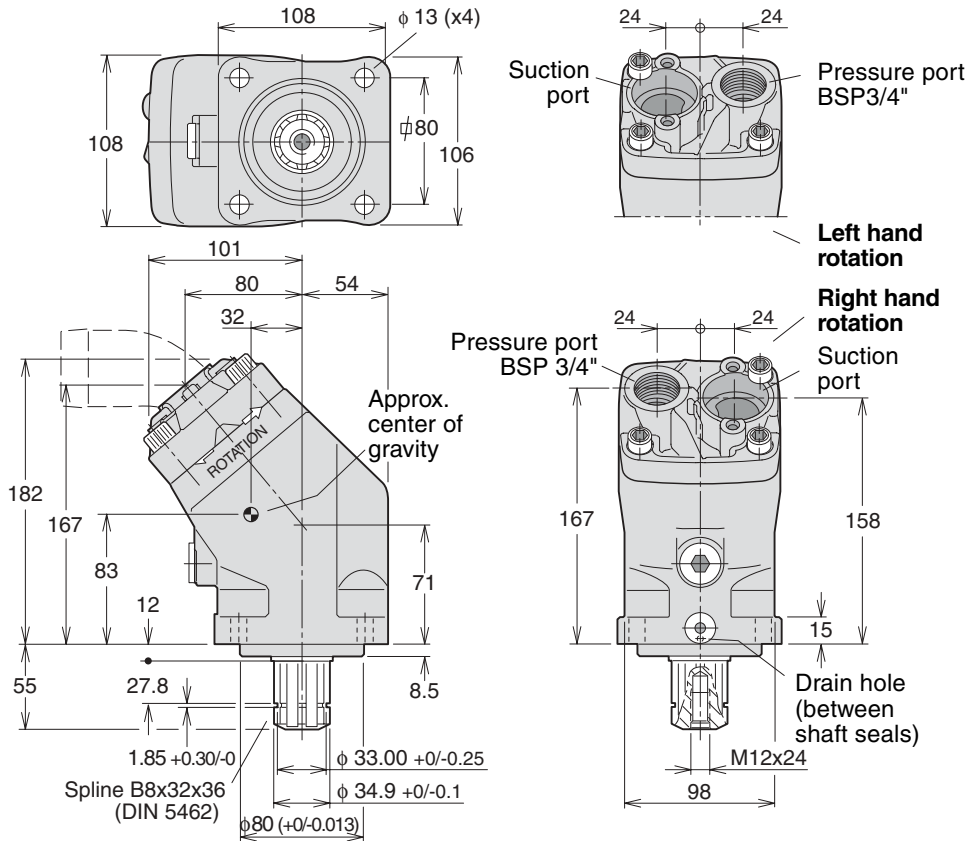

**Installation dimensions, T1-81**

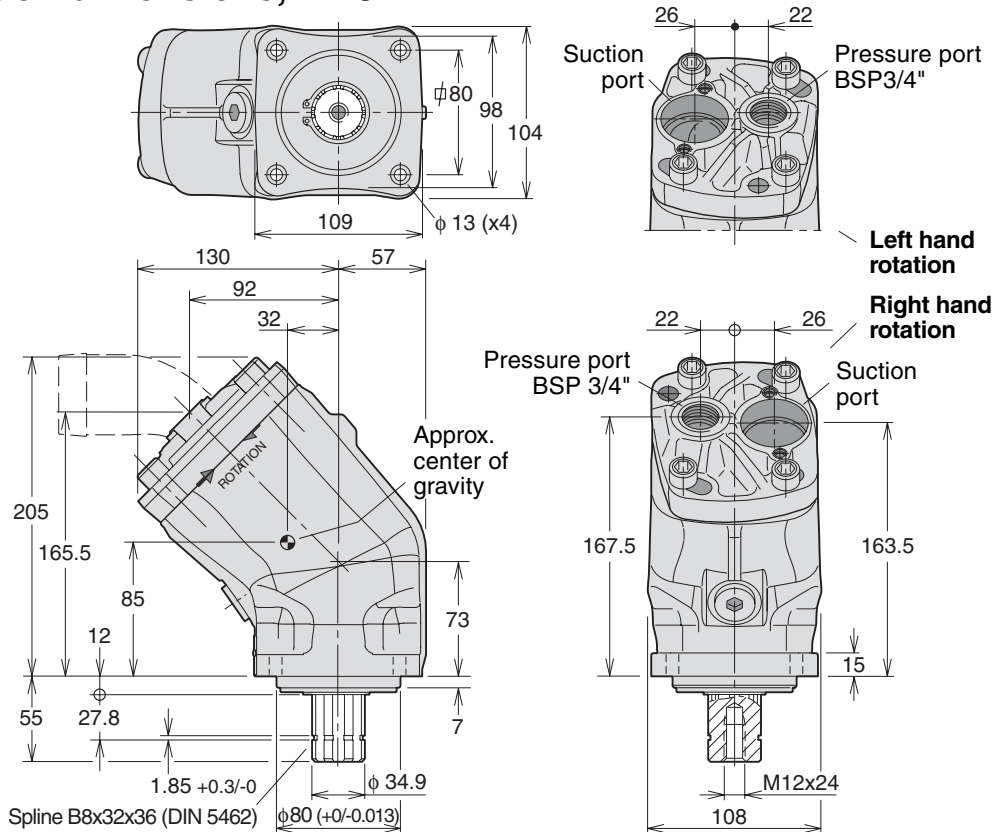

### Installation dimensions, T1-121

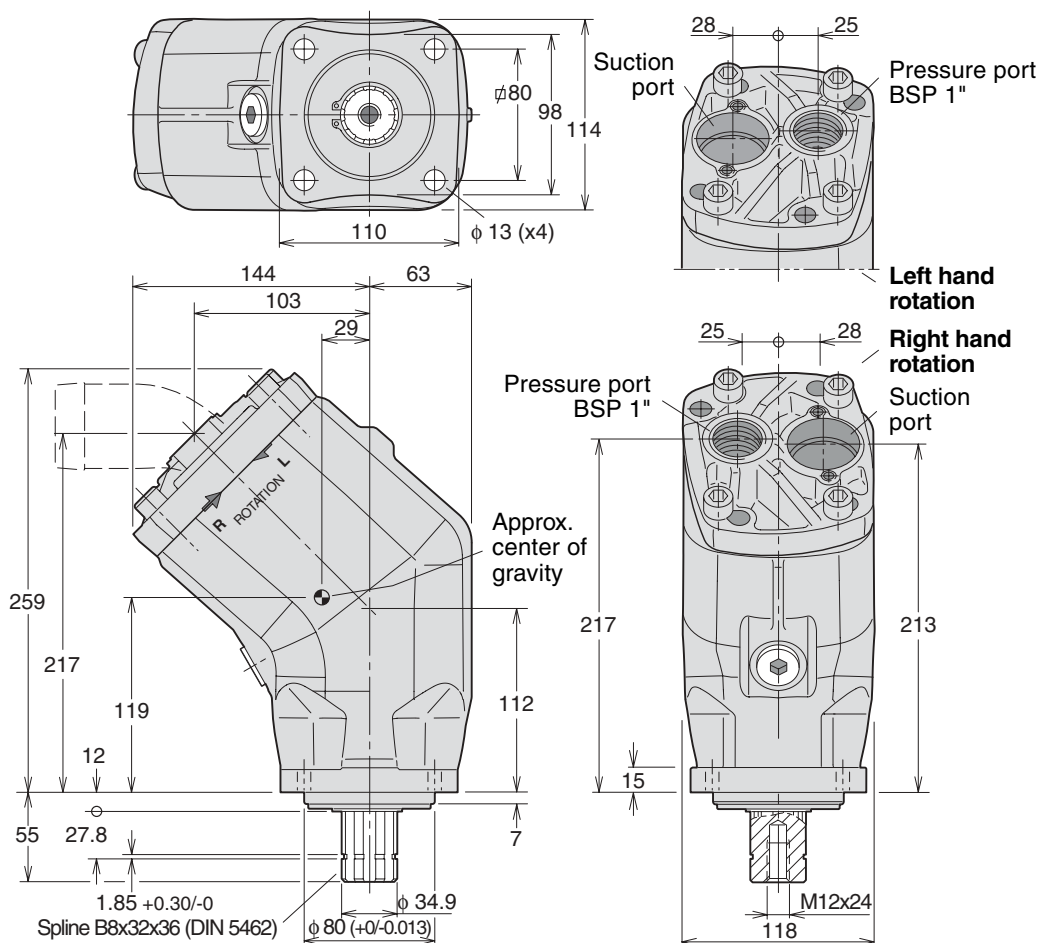

6

### Ordering code

Example: **T1 - 81 - R**

T1 frame size **51, 81 or 121**

Shaft rotation  
**R** Right hand  
**L** Left hand

### Standard versions

| Designation | Ordering no. |
|-------------|--------------|
| T1-51-R     | 378 2250     |
| -L          | 378 2251     |
| T1-81-R     | 378 2180     |
| -L          | 378 2181     |
| T1-121-R    | 378 2120     |
| -L          | 378 2121     |

### Port size

| T1 frame size | Pressure port <sup>1)</sup> |
|---------------|-----------------------------|
| -51           | 3/4"                        |
| -81           | 3/4"                        |
| -121          | 1"                          |

1) BSP thread (fitting not included).

**NOTE:** The T1 pump **does not** include a suction fitting; it must be ordered separately. See chapter 9.

# VP1 Pump



| Content                           | Page | Chapter |
|-----------------------------------|------|---------|
| Line dimensioning .....           | 10   | 2       |
| Specifications .....              | 31   |         |
| VP1 cross section .....           | 31   |         |
| Installation dimensions .....     | 32   |         |
| Ordering information .....        | 32   |         |
| VP1 in load sensing systems ..... | 33   |         |
| VP1-LS load sensing control ..... | 34   |         |
| LS valve block .....              | 35   |         |
| Through-shaft coupling .....      | 35   |         |
| Suction fittings .....            | 37   | 9       |
| Fluid data .....                  | 63   | 12      |
| Drain line .....                  | 63   | 12      |
| Installation and start-up .....   | 64   | 12      |

**Specifications**

| Frame size                                     | VP1-45            | VP1-75  |
|--|-------------------|---------|
| <b>Max displacement</b> [cm <sup>3</sup> /rev] | 45                | 75      |
| <b>Max pressure</b> [bar]                      |                   |         |
| continuous <sup>1)</sup>                       | — 300 —           | — 300 — |
| intermittent <sup>2)</sup>                     | — 350 —           | — 350 — |
| <b>Response time</b> [ms]                      |                   |         |
| max-to-min                                     | 20-30             | 20-40   |
| min-to-max                                     | 90-120            | 100-140 |
| <b>Selfpriming speed</b> <sup>3)</sup> [rpm]   |                   |         |
| 2" suction line, max                           | 2200              | 1700    |
| 2 1/2" suction line, max                       | 2400              | 2100    |
| <b>Control type</b>                            | — LS —            |         |
| <b>Shaft end spline</b>                        | — DIN 5462 —      |         |
| <b>Mounting flange</b>                         | — ISO 7653-1985 — |         |
| <b>Weight</b> (with control) [kg]              | — 27 —            |         |

1) Refer to page 34, 'LS control'.  
 2) Max 6 seconds in any one minute.

3) At an inlet pressure of 1.0 bar (abs.)  
 with mineral oil at a viscosity of 30 mm<sup>2</sup>/s (cSt).

**VP1 cross section**

1. Inlet port
2. 'Top' purge plug
3. Return spring
4. Control
5. Setting piston (one of two)
6. Swash plate
7. Bearing shell
8. End cover
9. Spline (for mounting an auxiliary pump)
10. Bearing sleeve
11. Hold-down plunger
12. Valve plate
13. Cylinder barrel
14. Barrel housing
15. 'Bottom' purge plug
16. Piston with piston shoe
17. Retainer plate
18. Bearing housing
19. Roller bearing
20. Shaft seals with carrier
21. Input shaft

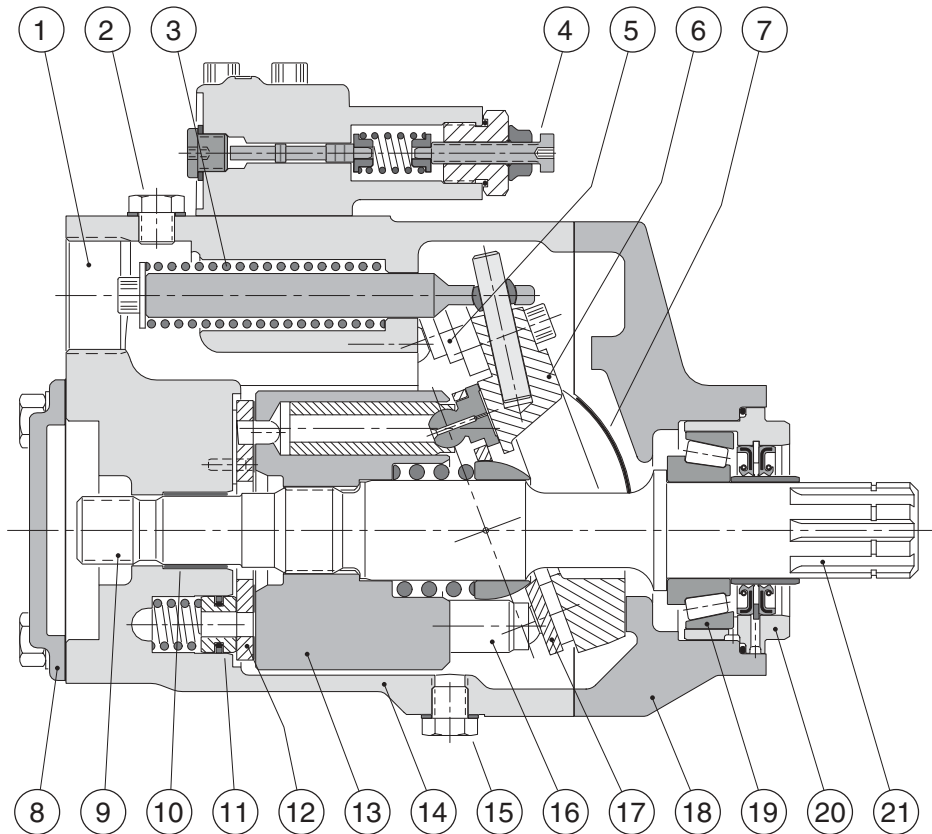

**Installation dimensions (VP1-45 and -75)**

**IMPORTANT**

The control is *not* drained through the pump case. An external line *must be installed* between the control drain port 'T' and the reservoir.

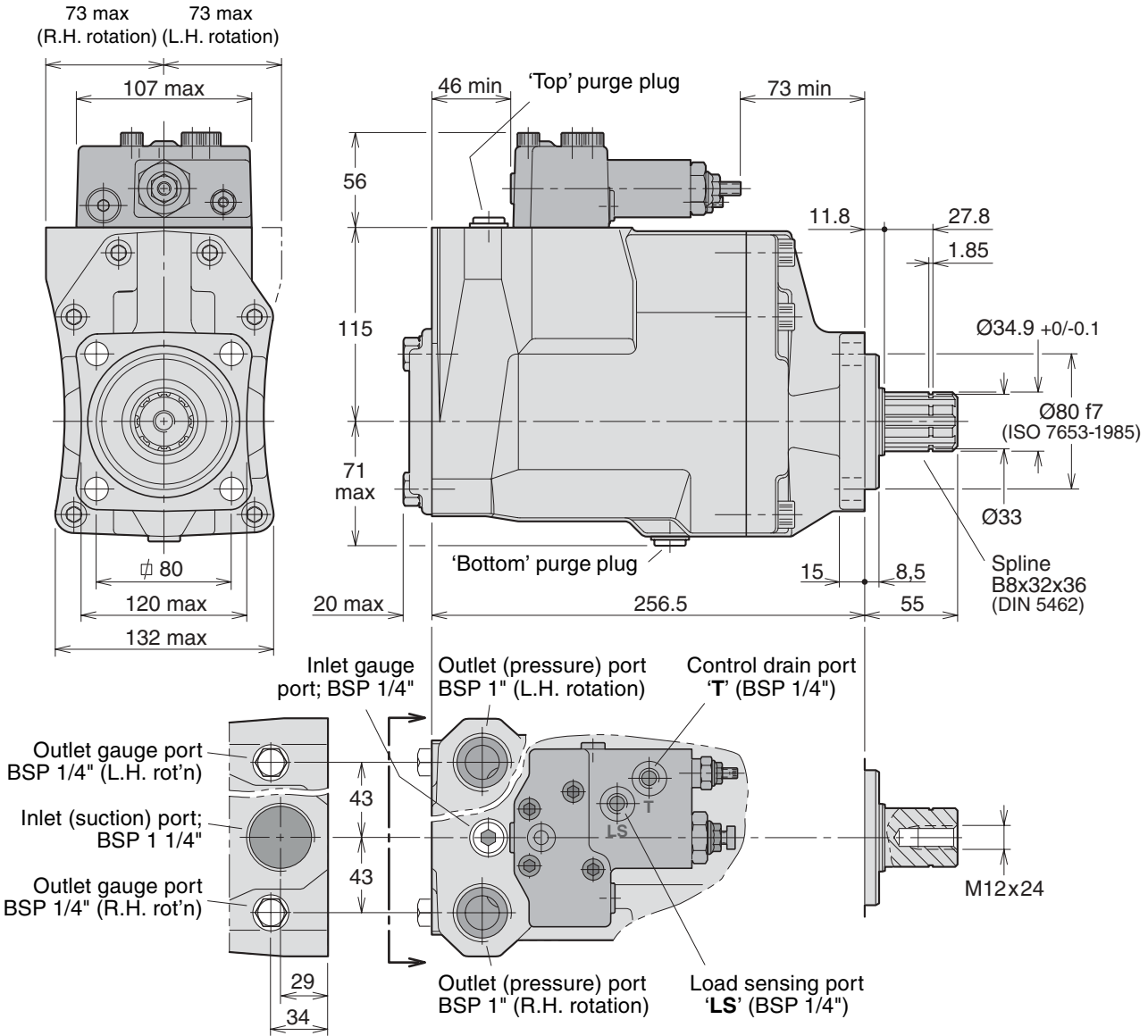

**Ordering information**

Example: **VP1 - 045 - L**  
 Frame size **45 or 75**  
 Direction of rotation  
**L** Left hand  
**R** Right hand

**NOTE:**  
 The VP1 is uni-directional. Consequently, the desired direction of rotation must be stated *when ordering*.

**Standard model numbers**

|           |          |
|-----------|----------|
| VP1-045-R | 378 0334 |
| VP1-045-L | 378 0335 |
| VP1-075-R | 378 0336 |
| VP1-075-L | 378 0337 |



### VP1 in load sensing systems

When installed in a load sensing system, the VP1 supplies the correct amount of flow required by the various work functions currently engaged. This means that energy consumption and heat generation are minimized and much reduced in comparison with a fixed displacement pump used in the same system.

Diagram 1 shows the required power (flow times pressure) in a constant flow system with a fixed displacement pump.

Diagram 2 shows the sharply reduced power requirement in a load sensing system with a variable displacement pump such as the VP1.

In both cases the pump pressure is slightly higher than what is required by the heaviest load ('Load 2') but the VP1, because of the much smaller flow being delivered, needs only the power indicated by the shaded area 'Load power'.

In a constant flow system, on the other hand, excess fluid is shunted to tank and the corresponding power, 'Wasted power' (shown in diagram 1), is a heat loss.

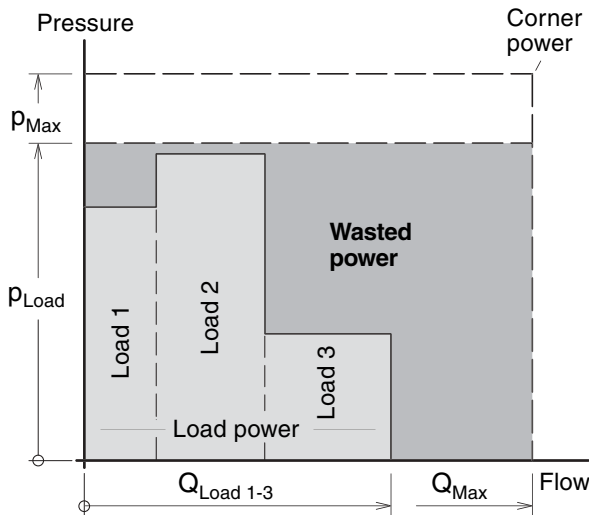

Diagram 1. Constant flow system with a fixed displacement pump.

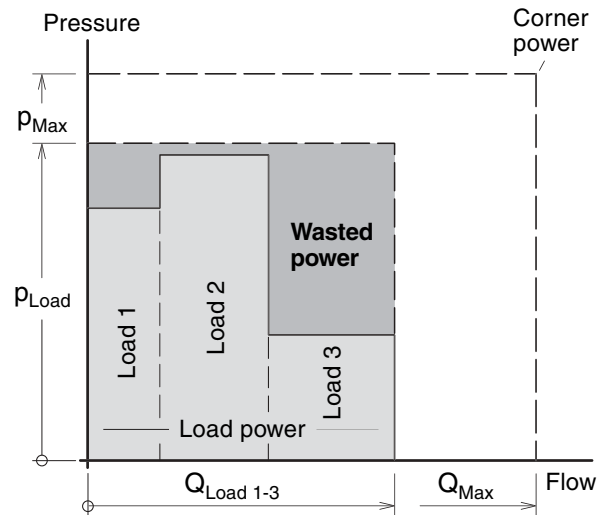

Diagram 2. Constant flow system with a variable displacement pump (e.g. VP1).

### Systems comparison

| System Pump        | Constant flow Fixed displ. | Load-sensing VP1 variable displ. |
|--------------------|----------------------------|----------------------------------|
| Pump adjustments   | Pressure only              | Pressure and flow                |
| Load*              | Some influence             | Some influence                   |
| Energy consumption | High                       | Low                              |
| Heat generation    | High                       | Low                              |

\* Simultaneous operation of loads with non-equal flows and pressures; refer to the above diagrams.



## VP1-LS load sensing control

The VP1 pump with LS control can be used with any load sensing directional valve on the market. The control governs the pump flow to the main hydraulic system as determined by the pressure differential,  $\Delta p$ , between the pump pressure and the LS load signal pressure.

At a certain 'opening' of the directional valve, the pump flow is kept constant (up to max specified rpm and pressure limits of the pump) even if the pump pressure changes due to increasing or decreasing work load. The LS control (fig. 2) consists of a valve body, which installes on the main pump housing, a built-in spool-type load sensing control, and a pressure relief valve limiting the LS signal pressure. Both functions are adjustable.

The two-position, three-way spool valve is connected to system pressure, the LS load signal and the two setting pistons (fig. 1).

In the no-flow mode, the pump maintains a stand-by pressure as determined by the setting of the valve spring (there is no pressure in the LS signal line from the directional valve).

The pressure limiter consists of a cartridge valve (fig. 2); the setting limits the LS signal pressure.

## LS load sensing control function

Refer to the hydraulic schematic (fig. 1). A selected 'opening' of the directional control valve spool corresponds to a certain flow to the work function. This flow, in turn, creates a pressure differential over the spool and, consequently, also a  $\Delta p$  between the pump outlet and the LS port.

When the differential pressure decreases (e.g. the directional valve is 'opened' further) the  $\Delta p$  also decreases and the LS valve spool moves to the left. The pressure to the setting pistons then decreases and the pump displacement increases.

The increase in pump displacement stops when the  $\Delta p$  finally reaches the setting (e.g. 25 bar) and the forces acting on the valve spool are equal.

If there is no LS signal pressure (e.g. when the directional valve is in the neutral, no-flow position) the pump only delivers sufficient flow to maintain the standby pressure as determined by the  $\Delta p$  setting.

## LS control adjustments

### LS signal pressure limiter

The cartridge is factory set at 275 bar but is adjustable to 350 bar.

### LS load sensing valve

From factory, the  $\Delta p$  is set at 25 bar but is adjustable up to 35 bar.

The 25 bar setting and the standard orifice sizes shown in fig. 2 will usually provide an acceptable directional valve characteristic as well as system stability. For additional information, contact Parker Hannifin.

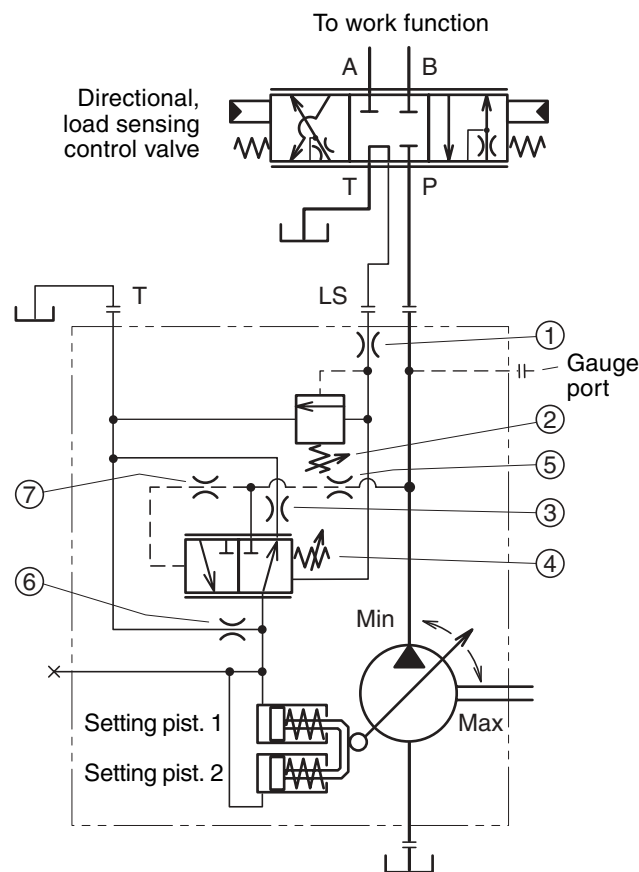

- |  |  |
|--|--|
| 1. Load signal orifice (1.0 mm; fixed)             | 5. System pressure dampening nozzle (2.0 mm) |
| 2. Signal pressure limiter adjustment              | 6. Bleed-off nozzle (0.6 mm)                 |
| 3. Return line nozzle (0.6 mm)                     | 7. Dampening nozzle (fixed)                  |
| 4. Differential pressure ( $\Delta p$ ) adjustment |  |

Fig. 1. Hydraulic schematic.

**LS valve block**

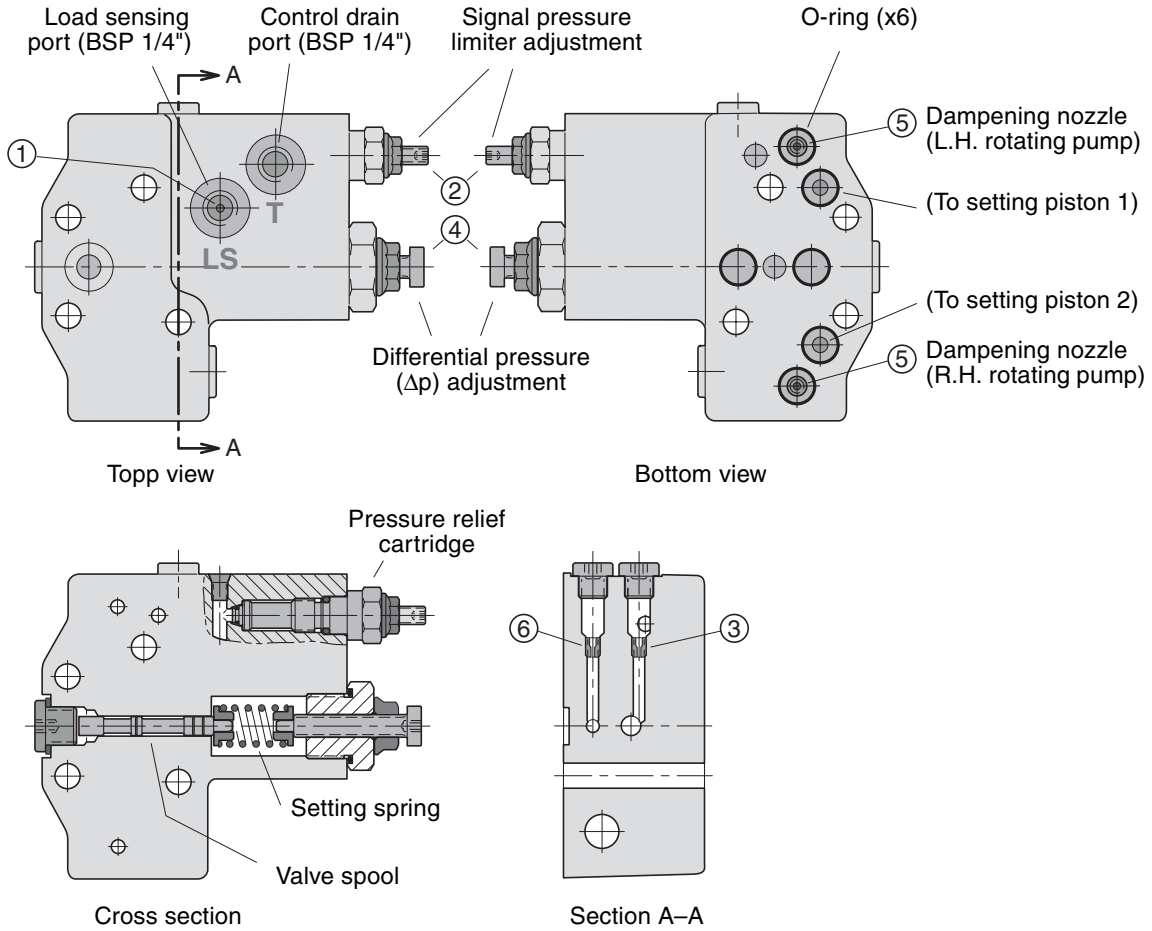

Fig. 2. LS valve block.

**Through-shaft coupling**

The VP1 pump has a through-shaft which means that an additional pump, such as a fixed displacement F1, can be installed in tandem with the VP1 by means of an adaptor kit (fig. 3).

**NOTE:** The bending moment caused by the weight of a tandem assembly normally exceeds that allowed by the PTO. To prevent damage, the auxiliary pump should be supported by a bracket attached to the gearbox; it *must not* be fastened to the truck chassis. Likewise, when the tandem assembly is installed on a separate bracket and driven by a cardan shaft, the auxiliary pump should have a support attached to the pump bracket.

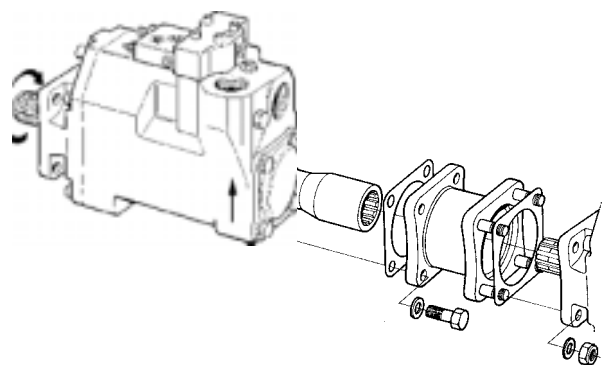

Fig. 3. Adaptor kit (P/N 379 7795) for tandem coupling.

**IMPORTANT**

Contact Parker Hannifin for additional information when considering tandem mounting a second VP1 pump.

# BLA

## General information

The BLA boost unit simplifies the building of closed or semi-closed hydrostatic transmissions.

### Main features are:

- Replaces conventional charge pump and corresponding valves in many applications
- Allows pump speeds above normal selfpriming speed
- Suitable for system flow rates to 400 l/min
- Includes filter
- Simple construction - no moving/wear parts
- Cost-effective installation
- Small tank size
- Helps in building a low-cost hydrostatic transmission.

## Description

In a closed circuit hydrostatic transmission, a charge pump is normally included with the main pump, providing make-up fluid which replaces pump and motor volumetric losses. It also maintains sufficient pump inlet pressure to avoid cavitation.

The BLA boost unit replaces the charge pump in many applications, when the following conditions are met:

- The max-to-min pump flow ratio does not exceed 2:1
- System pressure changes gradually without frequent and pronounced pressure peaks
- The line length between pump and boost unit is relatively short.

There are two basic sizes of the BLA boost unit:

- BLA 4 (to 160 l/min pump flow)
- BLA 6 (to 400 l/min).

The main part of the unit is an aluminium housing with a built-in nozzle and an injector; refer to the cross section to the right.

When fluid flows from the motor outlet port through the unit and to the pump inlet port, the increased fluid velocity between the nozzle and injector creates a low pressure zone causing additional fluid to be drawn from tank into the main circuit.

Also, pressure increases after the injector, allowing the pump to be operated at speeds higher than the self-priming speed. The 'boost pressure' increases with flow.

The housing includes ports that should be connected to the pump and motor drain ports respectively.

An additional bleed-off nozzle diverts approx. 10% of the main flow through the cartridge filter before being directed to the tank.

## Typical applications:

- Fan drives
- Propeller drives
- Generator drives
- Pump drives.

## Oil cooling

An oil cooler is usually required in the hydraulic system, in order to remove the heat that is generated in the main circuit. A full-flow oil cooler should be installed in the return line between the motor and the boost unit.

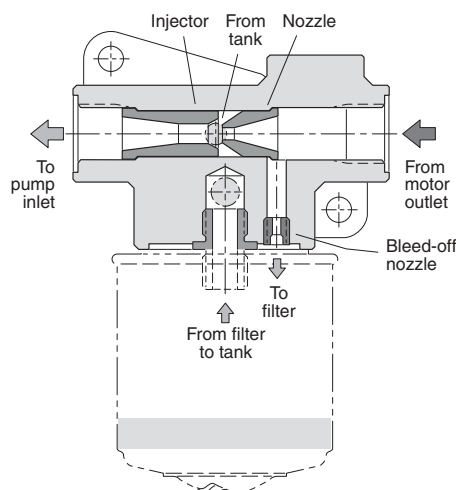

BLA boost unit cross section.

## Boost unit installation

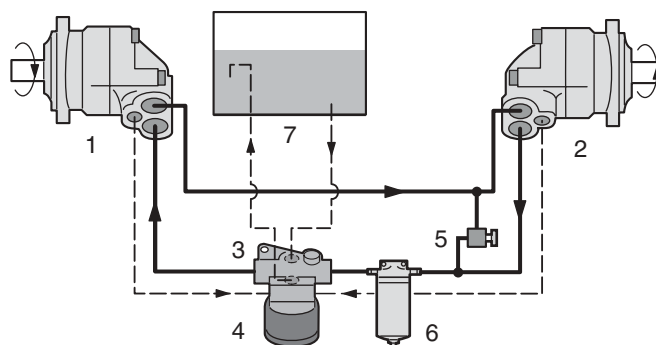

- |  |                                     |
|--|-------------------------------------|
| 1. Pump                                  | 5. Pressure relief valve            |
| 2. Motor                                 | 6. Full-flow filter (when required) |
| 3. Boost unit (with injector and nozzle) | 7. Reservoir                        |
| 4. Filter cartridge                      |                                     |

For more information please see our technical catalogue BLA boost unit HY17-8224/UK

# Fittings

## Suction fittings

for series F1, F2 and T1 pumps

A 'suction fitting' consists of a straight, 45°, 90° or 135° suction fitting, 2 clamps, 2 cap screws and an O-ring.

### 'Straight' suction fittings

| Ordering no. | A mm | B mm | C dia. mm (in.) |
|--------------|------|------|-----------------|
| 378 0635     | 0    | 85   | 38 (1 1/2")     |
| 378 0636     | 17   | 136  | 50 (2")         |
| 378 0637     | 25   | 145  | 63 (2 1/2")     |
| 378 0973     | 17   | 136  | 45              |
| 378 0974     | 17   | 136  | 48              |

### 45° suction fittings

| Ordering no.           | A mm | B mm | C dia. mm (in.) |
|------------------------|------|------|-----------------|
| 378 1234 <sup>1)</sup> | 60   | 104  | 32 (1 1/4")     |
| 378 0633 <sup>1)</sup> | 60   | 104  | 38 (1 1/2")     |
| 378 0364 <sup>2)</sup> | 67   | 110  | 50 (2")         |
| 378 0634               | 75   | 117  | 63 (2 1/2")     |
| 378 1062               | 67   | 110  | 40              |
| 378 0975               | 67   | 110  | 45              |
| 378 0965               | 67   | 110  | 48              |

1) Suitable for frame size F1-25.

2) Suitable for pump sizes F1-41,-51,-61,-81 and -110.

### 90° suction fittings

| Ordering no. | A mm | B mm | C dia. mm (in.) |
|--------------|------|------|-----------------|
| 378 0978     | 126  | 83   | 38 (1 1/2")     |
| 378 0979     | 135  | 83   | 50 (2")         |
| 378 0976     | 135  | 83   | 45              |
| 378 0977     | 135  | 83   | 48              |
| 378 1980     | 147  | 103  | 63 (2 1/2")     |

### 135° suction fitting

| Ordering no. | A mm | B mm | C dia. mm (in.) |
|--------------|------|------|-----------------|
| 378 1867     | 166  | 73   | 50 (2")         |

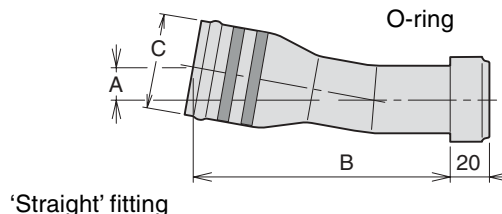
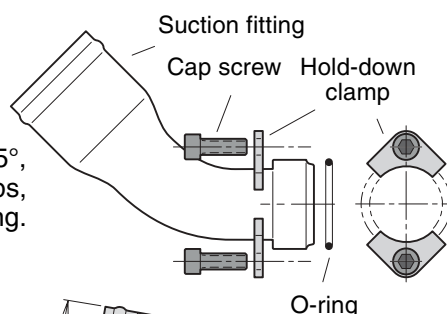

'Straight' fitting

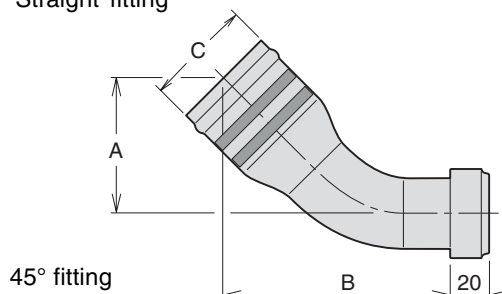

45° fitting

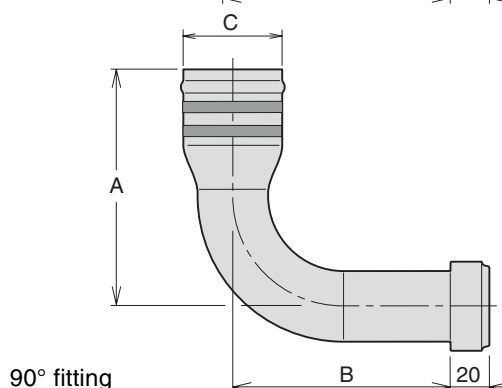

90° fitting

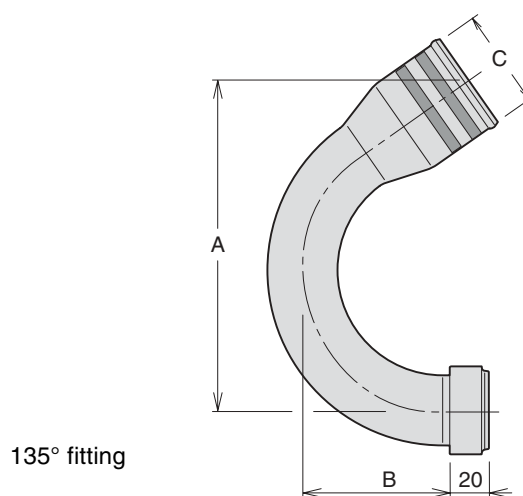

135° fitting

**NOTE:** A suction fitting *must be ordered separately* (not included with the pump).

8

9

# Fitting kits

for series F1 and VP1 pumps

## Kits with straight suction fitting

| Pump size        | Ordering no.    | C <sub>1</sub> | C <sub>2</sub> dia. |
|------------------|-----------------|----------------|---------------------|
| F1-20/-30        | <b>370 4934</b> | BSP 1/2"       | 1 1/2"              |
| F1-40/-60        | <b>370 4935</b> | BSP 3/4"       | 2"                  |
| F1-80/-110; VP1  | <b>370 4936</b> | BSP 3/4"       | 2"                  |
| F1-80/-110; VP1* | <b>370 7220</b> | BSP 1"         | 2"                  |

\* Above 100 l/min

Pressure fitting

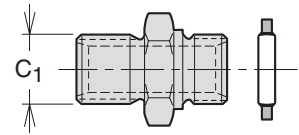

Straight suction fitting

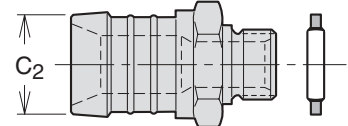

## Kits with 45° suction fitting

| Pump size        | Ordering no.    | C <sub>1</sub> | C <sub>2</sub> dia. |
|------------------|-----------------|----------------|---------------------|
| F1-20/-30        | <b>370 9017</b> | BSP 1/2"       | 2"                  |
| F1-40/-60        | <b>379 9564</b> | BSP 3/4"       | 2"                  |
| F1-80/-110; VP1  | <b>379 9563</b> | BSP 3/4"       | 2"                  |
| F1-80/-110; VP1* | <b>379 9562</b> | BSP 1"         | 2 1/2"              |

Pressure fitting

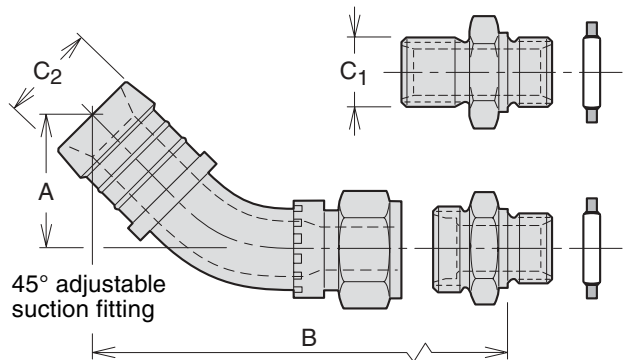

45° adjustable suction fitting

| Pump size        | A  | B   |
|------------------|----|-----|
| F1-20/-30        | 71 | 154 |
| F1-40/-60        | "  | "   |
| F1-80/-110; VP1  | "  | "   |
| F1-80/-110; VP1* | 64 | 147 |

\* Above 100 l/min

Pressure fitting

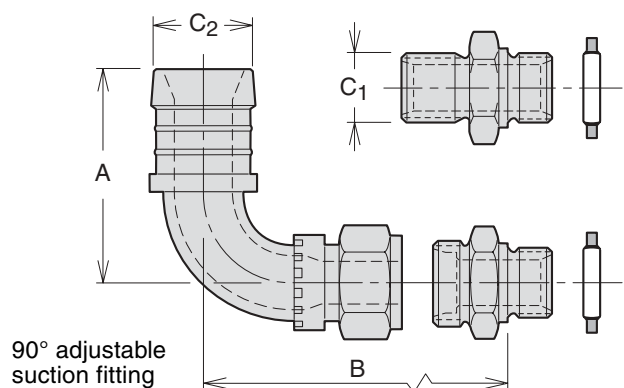

90° adjustable suction fitting

## Kits with 90° suction fitting

| Pump size       | Ordering no.    | C <sub>1</sub> | C <sub>2</sub> dia. |
|-----------------|-----------------|----------------|---------------------|
| F1-20/-30       | <b>379 9915</b> | BSP 1/2"       | 2"                  |
| F1-40/-60       | <b>379 9916</b> | BSP 3/4"       | 2"                  |
| F1-80/-110; VP1 | <b>379 9918</b> | BSP 1"         | 2"                  |

| Pump size       | A   | B   |
|-----------------|-----|-----|
| F1-20/-30       | 144 | 128 |
| F1-40/-60       | "   | "   |
| F1-80/-110; VP1 | "   | "   |

**NOTE:** Each kit consists of a pressure fitting, a suction fitting, and corresponding seal washers.

# Auxiliary Valves

## Bypass Valves for F1, F2, T1 and VP1 pumps

| Contents                                | Page |
|---|------|
| <b>Bypass valve:</b>                    |      |
| - BPV-F1 -25 and -81 .....              | 40   |
| - BPV-F2 .....                          | 41   |
| - BPV-F1/-T1 .....                      | 42   |
| - BPV-T1 .....                          | 43   |
| - BPV-L, line mounted .....             | 44   |
| - BPV-VP1 .....                         | 44   |
| <b>Unloading valve:</b>                 |      |
| - ES line mounted unloading valve ..... | 45   |
| <b>Accessories</b>                      |      |
| - MB-F2-H1 torque limiting valve .....  | 46   |

**BPV-F1-25 and -81 bypass valve**

- The bypass valve is mainly utilized in applications where the F1 pump is driven from the crank-shaft through a cardan shaft, or when it is installed on an engine PTO.
- The BPV bypass valve should be engaged during transportation when the pump is operating constantly and the engine is running at max rpm; the hydraulic system is not sized for the large flow that would otherwise go through it.
- The BPV valve substantially reduces the energy loss during transportation.
- The valve installs directly on top of the pump end cap with a pressure port 'banjo' fitting and an inlet port spacer bushing with two cap screws; refer to the illustration to the right.
- As the BPV valve is symmetrical, it can be 'turned 180°' to prevent interference with chassis components; it can be utilized for either left hand or right hand pumps.
- The valve function must only be activated or released (by means of the 24 VDC solenoid) at *no-load* (below 20 bar) *system pressure*.

**IMPORTANT INFORMATION**

- In order to prevent heat build-up in the pump during transportation, it is important that at least 5 l/min comes out of the filter at 'q' (refer to the schematic). This applies to an 'open center' system when the valve is in the bypass mode (non-activated solenoid).
- *Please note:*
  - a) If the flow at 'q' is less than 5 l/min (caused e.g. by a high pressure drop in the main system) when the valve is in the bypass mode, or
  - b) if the hydraulic system is of the 'closed center' type, then
an external drain line **must be installed** from the bypass valve drain port directly to tank as shown in the schematic; a drain kit is available (see below).

Bypass valve, type **BPV-F1-25/-81**

|                                |   |
|--------------------------------|---|
| Max pressure, continuous [bar] | 350                                       |
| intermittent [bar]             | 400                                       |
| Solenoid voltage [VDC]         | 24  |
| Power requirement [W]          | 17  |
| Operating mode                 | Activated solenoid:<br>Check valve closed |

| Bypass valve kits | Ordering number | For F1 size   | Torque press. connector to: |
|-------------------|-----------------|---|-----------------------------|
| BPV-F1-25, 24 VDC | <b>378 1401</b> | -25/-41/  | 50 Nm                       |
| 12 VDC            | <b>378 1318</b> | -51/-61   |                             |
| BPV-F1-81, 24 VDC | <b>378 1402</b> | -81/-101  | 100 Nm                      |
| 12 VDC            | <b>378 1319</b> |   |                             |
| O-ring kit        | <b>378 0641</b> | Contains all five O-rings (as illustrated to the right); included in all valve kits |                             |
| Drain fitting kit | <b>378 1640</b> | Contains a drain line fitting and a bonded seal.                                    |                             |

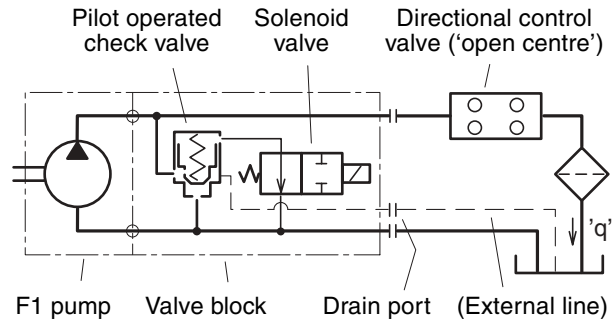

*Bypass valve schematic.*

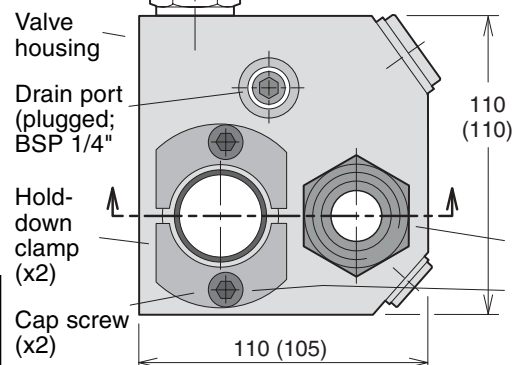
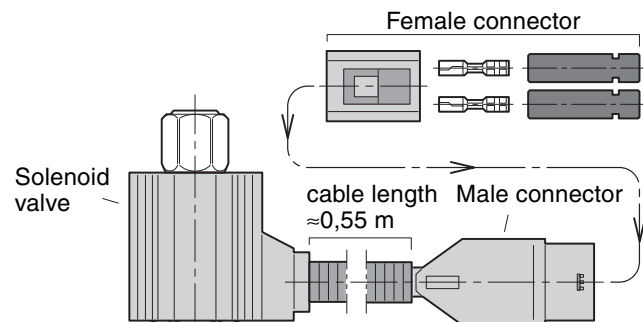
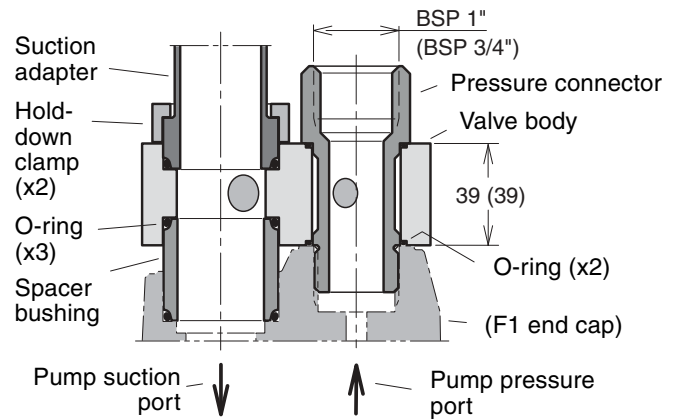

**IMPORTANT:** Always tighten the pressure connector before tightening the cap screws. Also see table to the left.

**NOTE:** Dimensions are shown for BPV-F1-81 (those for BPV-F1-25 are in paranthesis)

*Bypass valve installation and cross section.*



**BPV-F2 bypass valve**

- An F2 twin pump fitted with a bypass valve can be utilized in applications where the pump is operating constantly i.e. when the pump is driven from the crankshaft through a propshaft, or when it is installed on a PTO. In addition, it can be used when, temporarily, one of the two circuits is not required; the power loss is thus reduced as the non-required flow is not forced through lines and 'open center' valves.
- In most cases, the bypass valve allows the pump to be driven at max engine rpm during transportation at a minimum load. This prevents pump cavitation and high heat generation which may otherwise be encountered at large flows.
- The BPV valve connects the outlet and inlet ports of the pump, and only a small oil flow goes through the system and to the reservoir.
- The valve is installed directly on top of the pump port surface with 'banjo' fittings and two cap screws (refer to the split view to the right).
- As the BPV valve is symmetrical it can be 'turned 180°' so as not to interfere with chassis components. The valve can accommodate left hand as well as right hand rotating pumps.
- The valve can only be engaged or disengaged (through the 24 or 12 VDC solenoid) at low system pressures (below 20 bar).

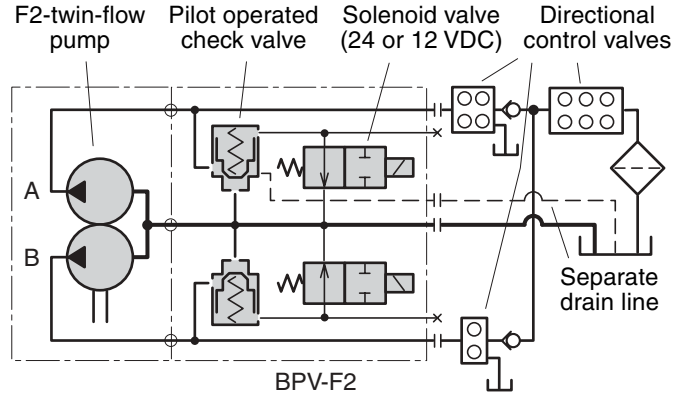

*Bypass valve circuit schematic (example).*

**IMPORTANT INFORMATION**

- In order to secure a cooling flow through the system, a separate drain line **must** be connected from the BPV-F2 drain line fitting (shown in the split view) directly to tank; refer also to the schematic.
- The pressure connectors must be tightened (to 50 Nm) before the suction fitting clamp screws are tightened.

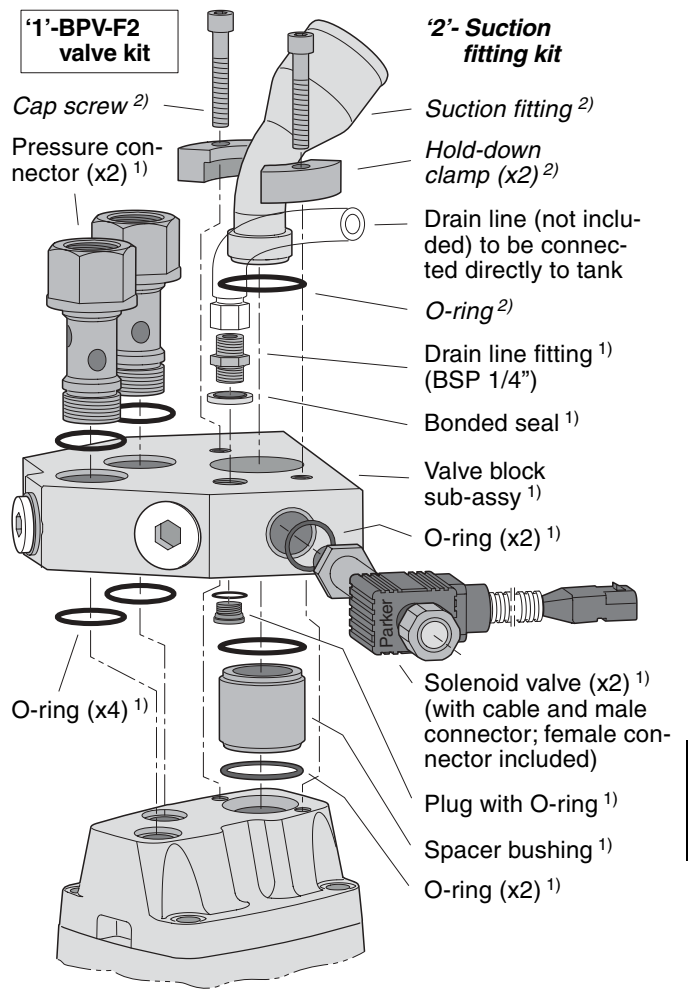

*Bypass valve split view (with F2 end cap).*

**NOTE:** A suction fitting kit (parts designated '2' in the split view) is **not** included with the F2 pump; it must be ordered separately (refer to chapter 9).

| Bypass valve, type                         | BPV-F2                                    |   |
|--|---|---|
| Max operating pressure [bar]               | 350                                       |   |
| Solenoid voltage [VDC] standard (optional) | 24 (12)                                   |   |
| Power requirement [W]                      | 17 (each solenoid)                        |   |
| Operating mode                             | Activated solenoid:<br>Check valve closed |   |
| Bypass valve kits                          | Ordering number                           | Torque press. connector to:   |
| BPV-F2, 24 VDC                             | <b>378 1459</b>                           | 50 Nm   |
| 12 VDC                                     | <b>378 1567</b>                           |   |
| O-ring kit                                 | <b>378 0641</b>                           | Contains all five O-rings (as illustrated to the right); included in all valve kits |

1)The BPV-F2 valve kit contains parts designated '1' in the split view to the right.  
 2) Contains all O-rings shown in the split view .

### BPV-F1/-T1 bypass valve

- An F1 or T1 pump supplied with a bypass valve can be utilized in applications where the pump is operating constantly i.e. when the pump is driven from the crankshaft through a propshaft or belt, or when it is installed on a PTO.
- In most cases, the bypass valve allows the pump to be driven at max engine rpm during transportation at no load. This prevents pump cavitation and high heat generation which may otherwise be encountered at large flows.
- The BPV valve connects the outlet and inlet ports of the pump, and only a small oil flow goes through the system to tank.
- The valve is installed directly on top of the pump port surface with 'banjo' fittings.
- As the BPV valve is symmetrical it can be 'turned 180°' to suit either left hand or right hand pump rotation, or to prevent interference with chassis components.
- The valve can only be engaged or disengaged (through the 12 or 24 VDC solenoid) at no-load system pressure.

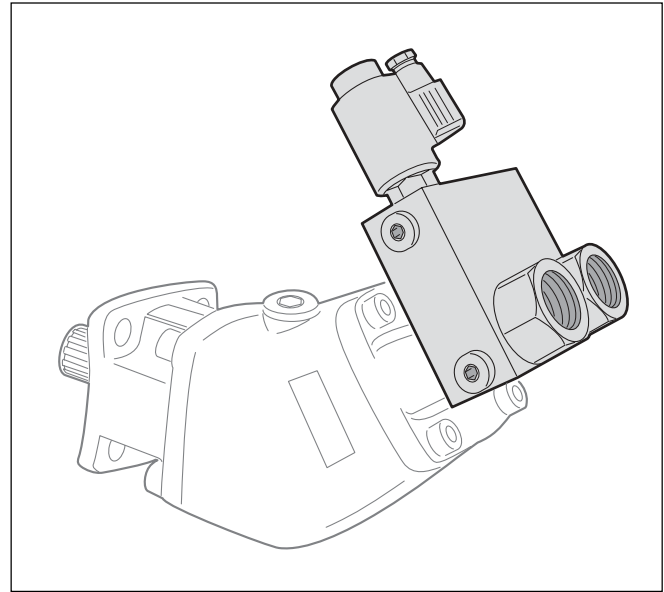

| Bypass valve, type                            | BPV-F1/-T1                                |
|---|---|
| Max operating pressure [bar]                  | 350                                       |
| Solenoid voltage [VDC]<br>standard (optional) | 24 (12)                                   |
| Power requirement [W]                         | 17  |
| Operating mode                                | Activated solenoid:<br>Check valve closed |

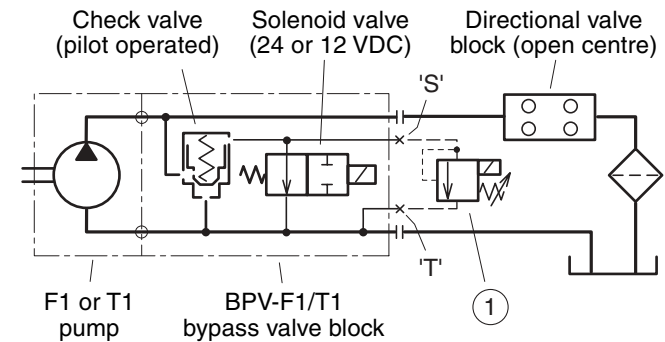

1. To limit system pressure, a 1/4" relief valve (not included) can be installed between pilot gauge port S and inlet gauge port T.

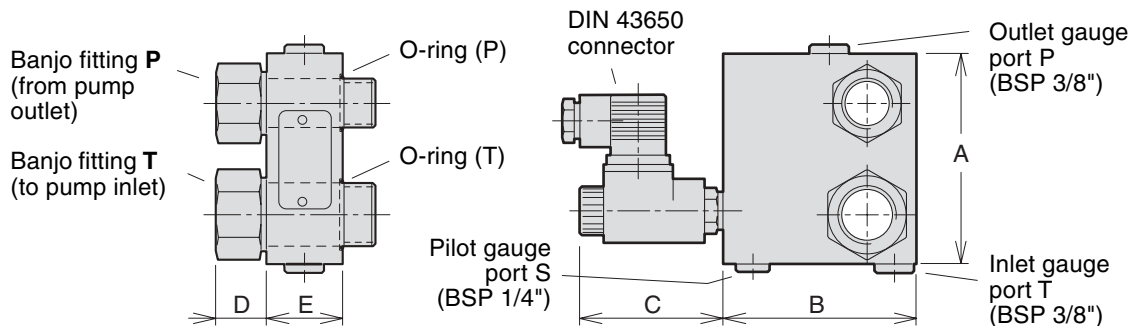

| Bypass valve designation | Ordering number |  | Dimensions [mm] |     |    |    |    | BSP thread |      | Torque [Nm] |     |
|--------------------------|-----------------|--|-----------------|-----|----|----|----|------------|------|-------------|-----|
|                          | 24 VDC          | 12 VDC   | A               | B   | C  | D  | E  | T          | P    | T           | P   |
| BPV-F1-20/30             | <b>379 2123</b> | —  | 105             | 100 | 74 | 26 | 40 | 3/4"       | 1/2" | 50          | 50  |
| BPV-F1-40/60             | <b>370 8086</b> | 379 7508   | 115             | 100 | 74 | 26 | 40 | 1"         | 3/4" | 50          | 50  |
| BPV-F1-80                | <b>379 1962</b> | 379 7509   | 130             | 100 | 74 | 26 | 40 | 1 1/4"     | 1"   | 100         | 100 |
| BPV-F1-110               | <b>370 8088</b> | 379 8775   | 140             | 100 | 74 | 26 | 40 | 1 1/4"     | 1"   | 100         | 100 |
| BPV-T1-50                | <b>379 4472</b> | —  | 115             | 100 | 74 | 26 | 40 | 1"         | 3/4" | 50          | 50  |
| O-ring kit               | <b>379 9883</b> | Contains banjo fitting O-rings for the above valves. |                 |     |    |    |    |            |      |             |     |

**BPV-T1-51/81 and -121 bypass valve**

- The bypass valve is mainly utilized in applications where the T1 pump is driven from the crankshaft through a cardan shaft, or when it is installed on an engine PTO.
- The BPV bypass valve should be engaged during transportation when the pump is operating constantly and the engine is running at max rpm; the hydraulic system is not sized for the large flow that would otherwise go through it.
- The BPV valve substantially reduces the energy loss during transportation.
- The valve installs directly on top of the pump end cap with a pressure port 'banjo' fitting and an inlet port spacer bushing with two cap screws; refer to the illustration to the right.
- As the BPV valve is symmetrical, it can be 'turned 180°' to prevent interference with chassis components; it can be utilized for either left or right hand pumps.
- The valve function must only be activated or released (by means of the 24 VDC solenoid) at *no-load* (below 20 bar) *system pressure*.

**IMPORTANT INFORMATION**

- In order to prevent heat build-up in the pump during transportation, it is important that at least 5 l/min comes out of the filter at 'q' (refer to the schematic). This applies to an 'open center' system when the valve is in the bypass mode (non-activated solenoid).
- *Please note:*
  - a) If the flow at 'q' is less than 5 l/min (caused e.g. by a high pressure drop in the main system) when the valve is in the bypass mode, or
  - b) if the hydraulic system is of the 'closed center' type (with a shunt), then
 an external line **must be installed** from the bypass valve drain port directly to tank as shown in the schematic; a drain fitting kit is available (below).

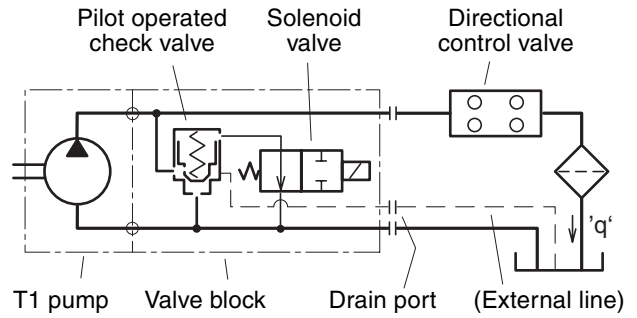

*Bypass valve schematic.*

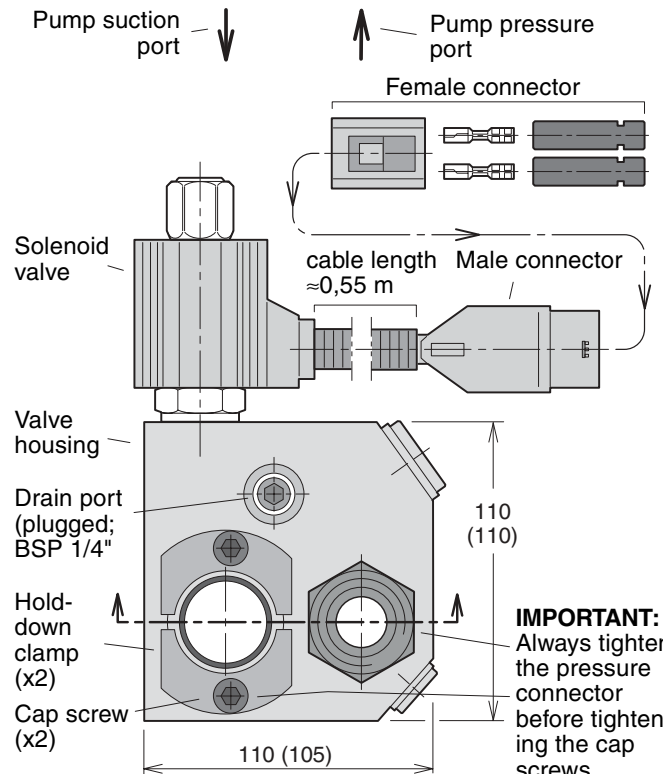
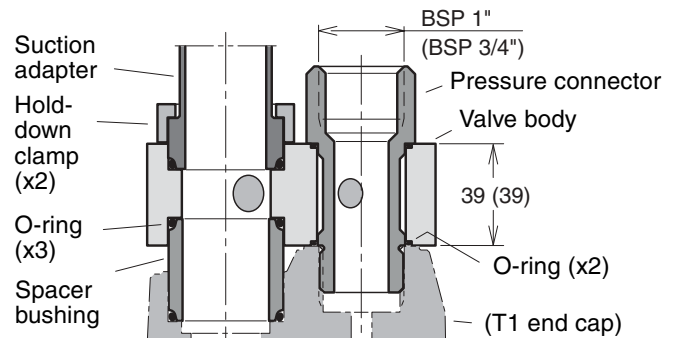

**IMPORTANT:** Always tighten the pressure connector before tightening the cap screws. Also see table to the left.

**NOTE:** Dimensions are shown for BPV-T1-121 (those for BPV-T1-81 are in paranthesis)

*Bypass valve installation and cross section.*

Bypass valve, type **BPV-T1-51/81 and -121**

|                                |   |
|--------------------------------|---|
| Max pressure, continuous [bar] | 200                                       |
| intermittent [bar]             | 350                                       |
| Solenoid voltage [VDC]         | 24 or 12                                  |
| Power requirement [W]          | 17  |
| Operating mode                 | Activated solenoid:<br>Check valve closed |

| Bypass valve kits  | Ordering number | Torque pressure connector to:   |                            |
|--------------------|-----------------|---|----------------------------|
| BPV-T-51/81, 24VDC | <b>378 1401</b> | 50 Nm   | Also see fig. to the right |
| 12VDC              | <b>378 1318</b> | " "   |                            |
| BPV-T1-121, 24VDC  | <b>378 1402</b> | 100 Nm  |                            |
| 12VDC              | <b>378 1319</b> | " "   |                            |
| O-ring kit         | <b>378 0641</b> | Contains all five O-rings (as illustrated to the right); included in all valve kits |                            |
| Drain fitting kit  | <b>378 1640</b> | Contains a drain line fitting and a bonded seal.                                    |                            |

**10**

**BPV-L line mounted bypass valve**

- The unloading valve is utilized in hydraulic systems where the fixed displacement pump is engaged constantly and no flow is required, i.e. during transportation. The flow is directed through the unloading valve which has a low pressure loss and less heat is being generated in the system.
- When the solenoid is activated the unloading valve closes and the pump flow is directed to the directional control valve or other user.

|                              |   |
|------------------------------|---|
| Unloading valve, type        | <b>BPV-L</b>                              |
| Max operating pressure [bar] | 350                                       |
| Max flow [l/min]             | 250                                       |
| Solenoid voltage [VDC]       | 24  |
| Required power [W]           | 17  |
| Operating mode               | Activated solenoid:<br>Check valve closed |
| Ordering number              | <b>378 1487</b>                           |

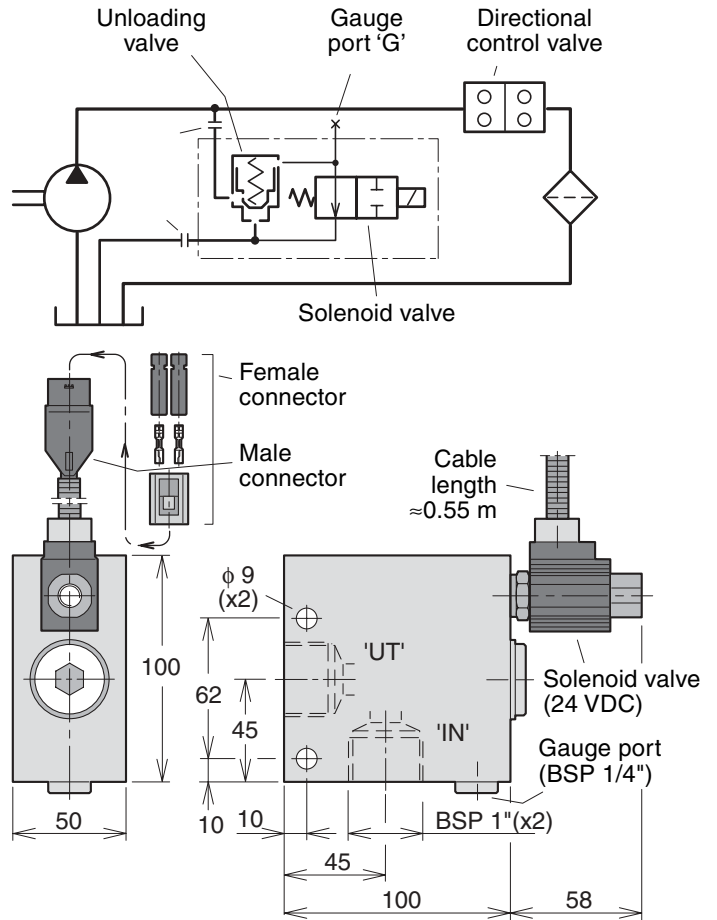

**BPV-VP1 unloading valve**

The BPV-VP1 unloading valve is utilized in hydraulic systems where the pump is operating constantly. The valve, which requires no additional control valve, allows the pump to operate on- or off-load up to its max selfpriming speed.

The valve protects the pump from overheating in the off-load mode by allowing a small flow through the pump (refer to the schematic to the right). When a load sensing valve function is engaged, the bypass flow is cut off (as port 'X' is being pressurized).

| Valve type | Ordering number | Rated flow [l/min] | Max press. [bar] |
|------------|-----------------|--------------------|------------------|
| BPV-VP1    | <b>379 8799</b> | 20                 | 350              |

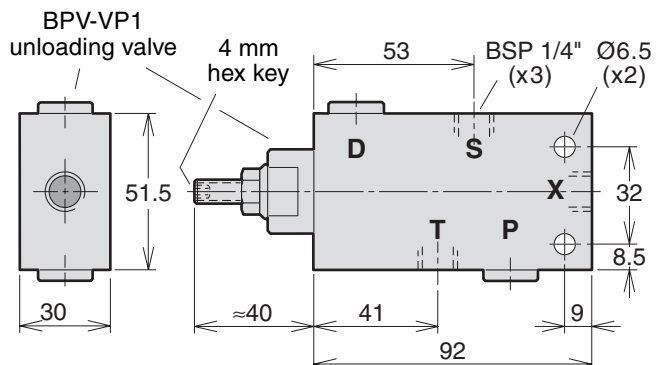
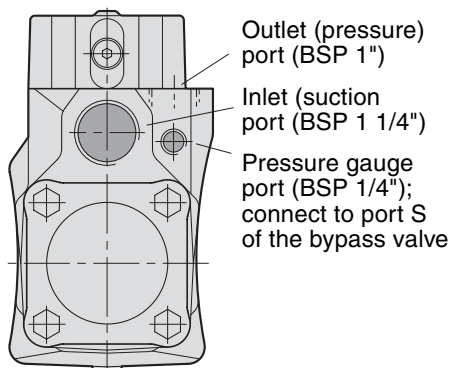
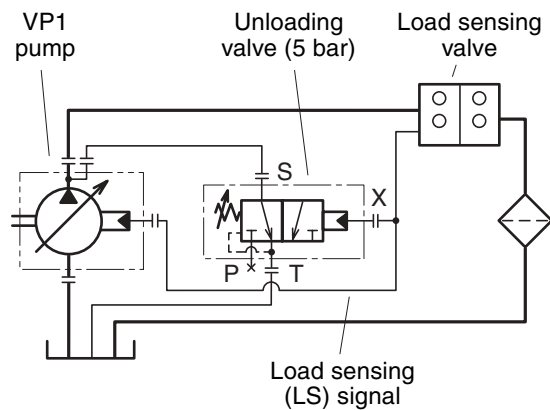

**ES line mounted unloading valve**

- The ES unloading valve is intended for hydraulic circuits with a fixed or variable displacement pump. The valve is available in two versions:
  - ES-CFO (for a system with a fixed displacement pump and a directional valve type CFO)
  - ES-LS (for a load sensing system with a variable displacement pump and a dir. control valve type LS).
- The valve block installs with M10 screws (alt. with M8 screws and nuts); main ports are BSP 1".
- The ES valve has a built-in, adjustable pressure relief valve (3).
- ES-CFO system function: When the solenoid is non-active (refer to the schematic below left) the entire pump flow goes through port T to tank and port P2 is blocked. An activated solenoid allows flow through the valve from P1 to P2.

- ES-LS system function: When the solenoid is being de-activated, the pump goes to min displacement and the reduced flow is directed through port T to tank; port P2 is blocked (refer to the schematic below right). When the solenoid is activated, the required pump flow goes through the valve from P1 to P2.

| Unloading valve design.    | ES-CFO          | ES-LS           |
|----------------------------|-----------------|-----------------|
| Max operating press. [bar] | 350             |                 |
| Max flow [l/min]           | 200             |                 |
| Solenoid voltage [VDC]     | 24*             |                 |
| Required power [W]         | 12              |                 |
| Non-activated solenoid:    | P1-to-T1        |                 |
| Activated solenoid:        | P1-to-P2        |                 |
| Ordering number            | <b>376 6684</b> | <b>376 7031</b> |

\* A 12 VDC solenoid is optional; contact Parker Hannifin.

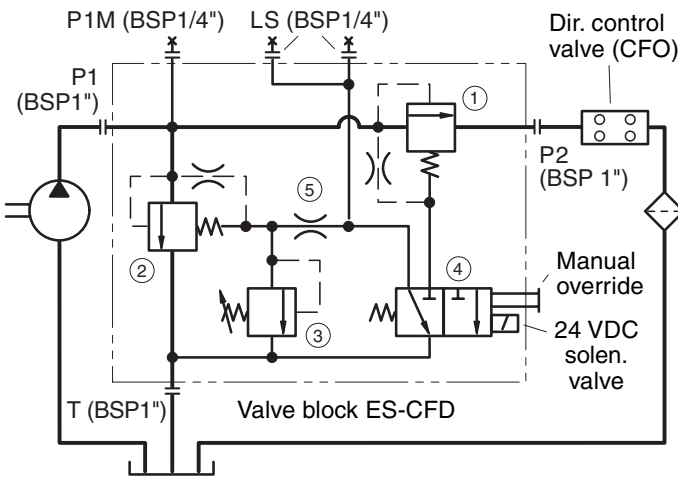

Hydraulic schematic - CFO system (example).

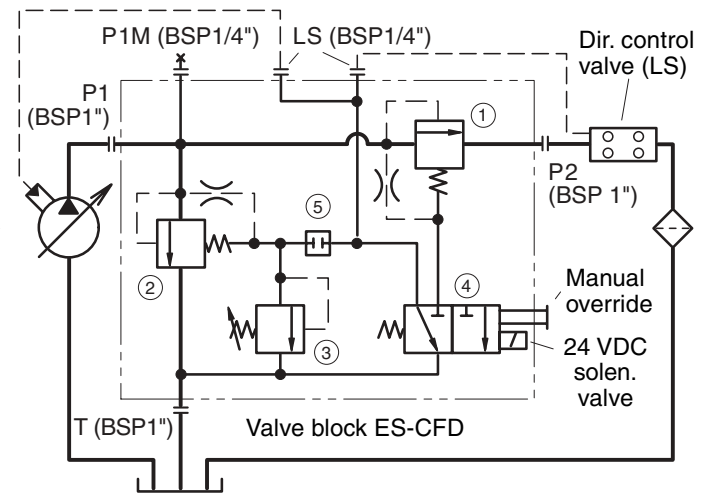

Hydraulic schematic - LS system (example).

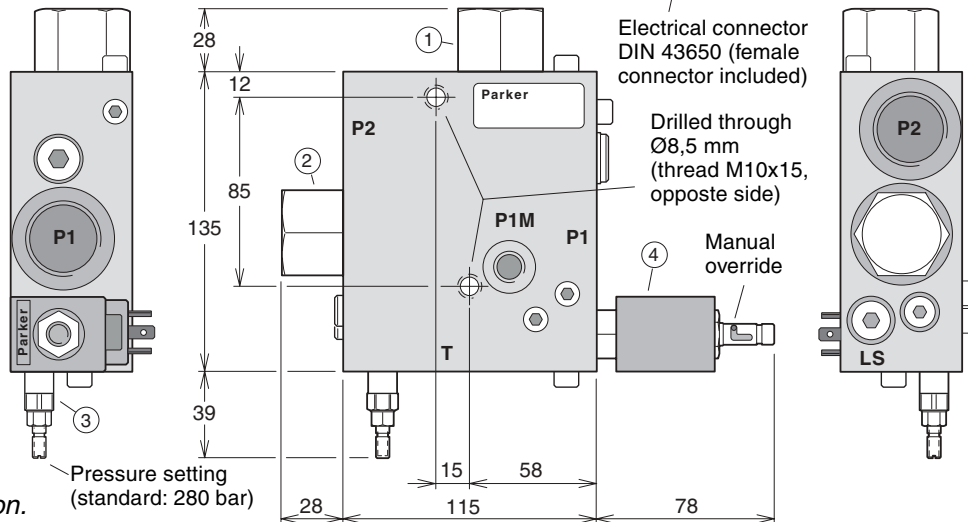
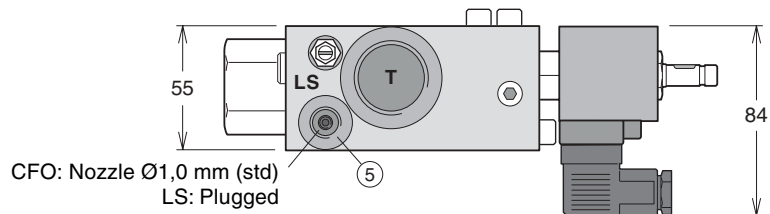

Installation information.

**10**

## MB-F2-H1 torque limiting valve

The torque limiting valve protects the PTO output shaft (which drives the hydraulic pump) from being overloaded. When the set pressure in the system is reached, the flow from the pump circuit connected to the valve is being unloaded; refer to the schematic.

### Pressure drop

The diagram below shows pressure drop (P-to-T) vs. flow when the set pressure is reached and the valve unloads one of the pump flows to tank.

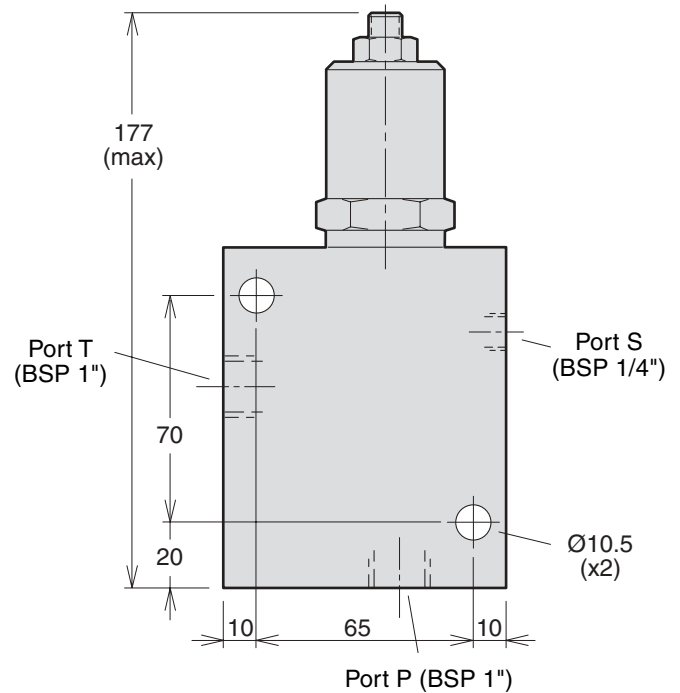
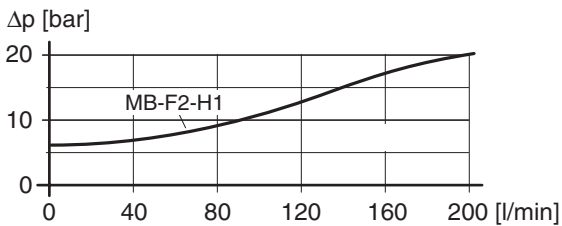

### Application examples

The following schematics show how the MB valve can be connected to the F2.

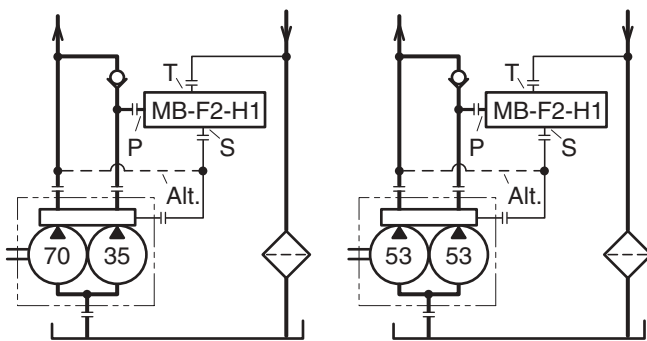

*MB-F2-H1 valve for system pressures to 350 bar (application examples)*

| Torque limiting valve  | <b>MB-F2-H1</b> |
|------------------------|-----------------|
| Max pressure [bar]     | 350             |
| Adjustment range [bar] | 150 – 350       |
| Ordering number        | <b>378 0202</b> |

# Accessories

## Adapter kits and accessories for F1, F2, T1 and VP1 pumps

| Contents  | Page | Chapter |
|---|------|---------|
| <b>PTO Air valve kits:</b>                                |      |         |
| - Volvo PTO's .....                                       | 48   |         |
| - Scania PTO's .....                                      | 48   |         |
| - Universal .....   | 48   |         |
| <b>PTO adapter kits:</b>                                  |      |         |
| - for Scania ED 90 engines .....                          | 49   |         |
| - for Scania ED 120 engines .....                         | 50   |         |
| - for Scania ED 140 engines .....                         | 51   |         |
| - for Scania ED 160 engines .....                         | 52   |         |
| - for Mercedes engines (Actros) .....                     | 53   |         |
| - ES, line mounted unloading valves .....                 | 45   | 10      |
| Cardan shafts, pump couplings and mounting brackets ..... | 54   |         |
| Pump couplings .....                                      | 55   |         |
| Return filter and filter indicator .....                  | 56   |         |
| Air breather filter .....                                 | 57   |         |
| Check valves .....  | 57   |         |
| SB splitter boxes .....                                   | 58   |         |

### Air valve kit for Volvo PTO's

- The air valve kit is suitable for operating a Volvo PTO on Series FM and FH truck chassis (FH introduced Nov. -98). All parts required to operate the PTO are included in the kit (as shown below).
- The air valve can be combined with other air valves on the chassis; this means a simple installation with a common air supply and a minimum of hoses.
- All electrical wires are pre-installed on the chassis. The relay should be installed in socket K1-14 behind the dashboard cover.
- Function:  
 The relay makes sure the PTO is being disengaged as soon as the 'ignition key' is turned off.  
 To re-engage the PTO, the operator has to put the switch back to neutral, and then move it to the 'ON' position.



Air valve kit for Volvo PTO's.

| PTO air valve kit                                  | Volvo   |
|--|---|
| Air valve nominal voltage [VDC]                    | 24  |
| Nominal current [A]                                | 0.4   |
| Required power [W]                                 | 9.6   |
| Max air pressure [bar]                             | 10  |
| Air hose size                                      | 1/4"  |
| Operating mode                                     | Activated solenoid:<br>Air valve open<br>and PTO engaged. |
| Ordering number,<br>series FM and FH <sup>1)</sup> | <b>378 1010</b>   |

1) Series FH(c) introduced Nov. -98.

### Air valve kit for Scania PTO's

- All parts required for operating a Scania PTO are included in the kit (shown below).
- The air valve kit is suitable for all Scania chassis, Scania Original PTO's, and PTO's from Parker Hannifin for Scania chassis.
- The air valve can be combined with other air valves on the chassis; this means a simple installation with a common air supply and a minimum of hoses.
- All electrical wires are pre-installed on the chassis.

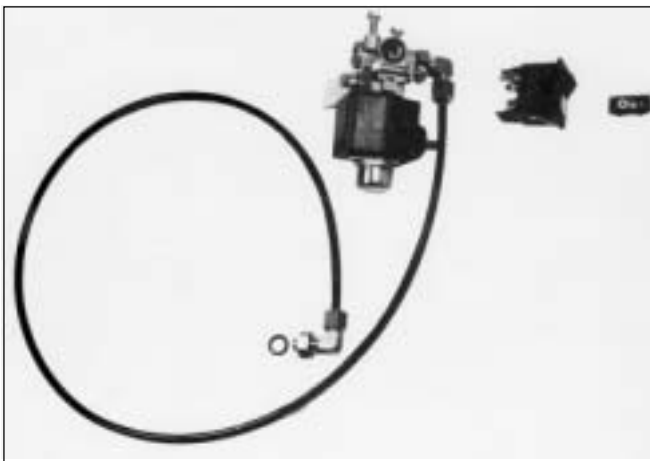

Air valve kit for Scania PTO's.

| PTO air valve kit               | Scania  |
|---------------------------------|---|
| Air valve nominal voltage [VDC] | 24  |
| Nominal current [A]             | 0.4   |
| Required power [W]              | 9.6   |
| Max air pressure [bar]          | 10  |
| Air hose size                   | 1/4"  |
| Operating mode                  | Activated solenoid:<br>Air valve open<br>and PTO engaged. |
| Ordering number                 | <b>370 5215</b>   |

### Universal PTO air valve kit

- The kit includes all parts required for maneuvering the PTO.
- The air valve kit is suitable for most PTO's with a metric M12x1.5 air connection.
- The air valve can be installed with other air valves on the chassis which means simple installation with common air supply and a minimum of hoses.
- The air valve can be connected to electrical wires usually pre-installed on the chassis.

| PTO air valve kit               | Universal   |
|---------------------------------|---|
| Air valve nominal voltage [VDC] | 24  |
| Nominal current [A]             | 0.4   |
| Required power [W]              | 9.6   |
| Max air pressure [bar]          | 10  |
| Air hose size                   | 1/4"  |
| Operating mode                  | Activated solenoid:<br>Air valve open<br>and PTO engaged. |
| Ordering number                 | <b>370 8779</b>   |



### PTO adapter kit for Scania ED 90 engines

- With the adapter kit, an hydraulic pump that meets the ISO standard can be installed on PTO of the Scania 9 liter engine DS/DSC 9.
- The PTO must be ordered with the chassis from Scania.
- For additional information please refer to Scania Service Information 19-86 03 30 GT SV.

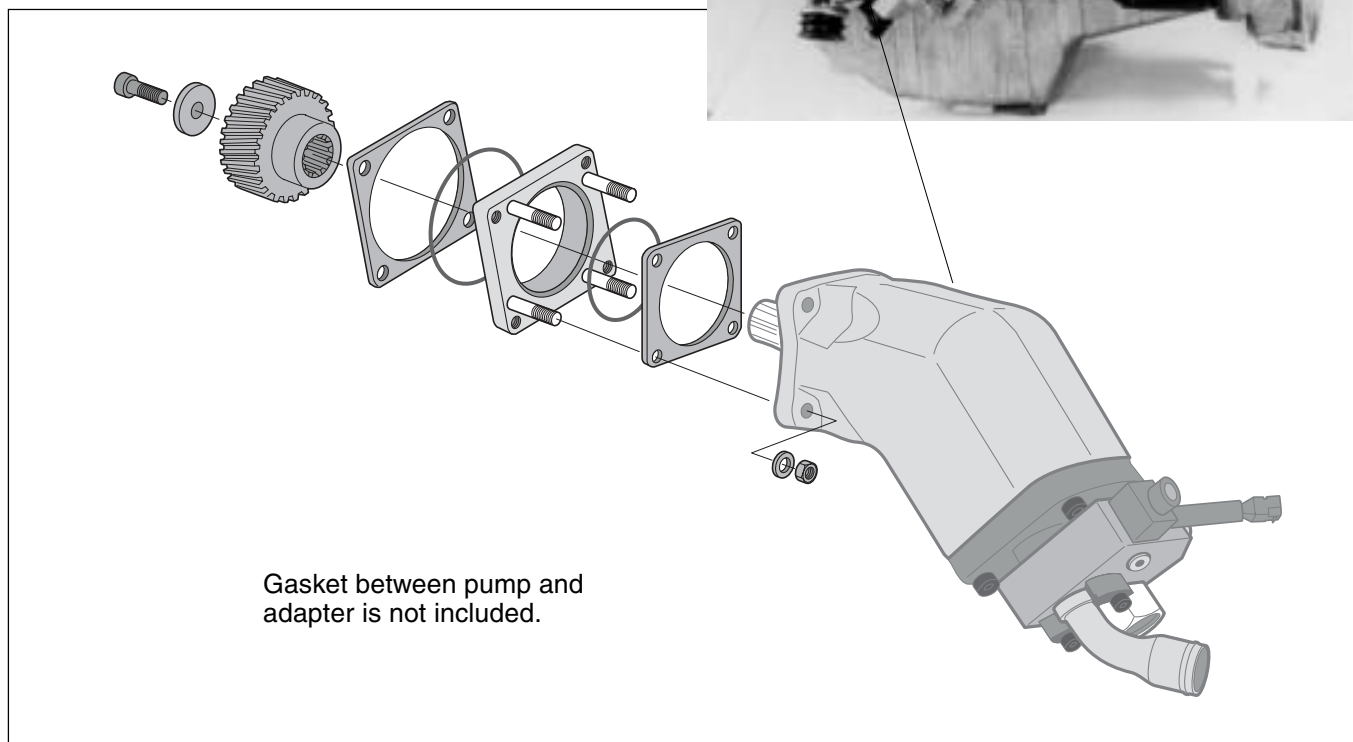
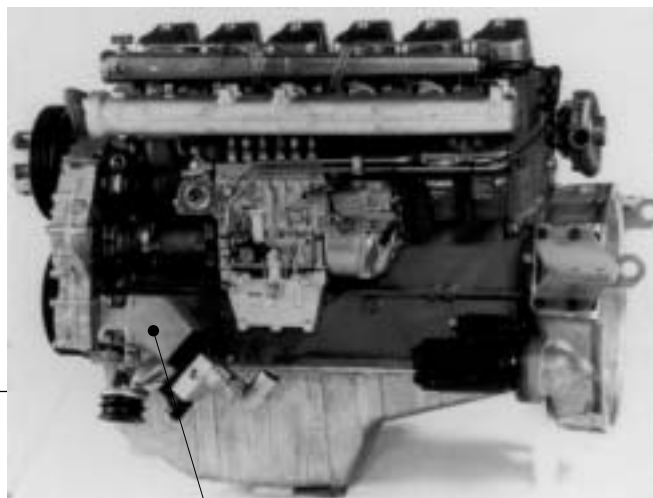

| Pump size                     | F1-25           | F1-41 | F1-51 | F1-61 | F1-81 | F1-101 | F2-53/53 | F2-70/35 |
|-------------------------------|-----------------|-------|-------|-------|-------|--------|----------|----------|
| Max. operating pressure [bar] | 350             | 350   | 350   | 350   | 223   | 235    | 220      | 220      |
| Bypass valve                  | <b>Required</b> |       |       |       |       |        |          |          |

**NOTE:** Max operating pressures shown for the F2 frame sizes are valid when both ports are pressurized to the same level simultaneously.

|                          |                        |
|--------------------------|------------------------|
| Max. torque [Nm]         | 360                    |
| Gear ratio (engine:pump) | 1 : 0.975              |
| Pump rotation            | Right hand (clockwise) |

| PTO adapter kit | Ordering number |
|-----------------|-----------------|
| Scania ED-90    | <b>379 1729</b> |

## PTO adapter kit for Scania ED 120 engines

- With the adapter kit, an hydraulic pump (e.g. F1 or VP1) that meets the ISO standard can be installed on the PTO of the Scania 12 liter engine.
- The PTO gear is supplied with the chassis.
- **Please note:** The engine must be ordered with a PTO.

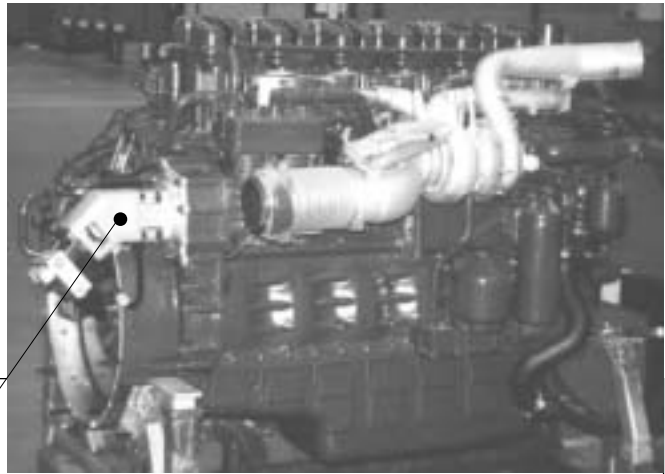

**NOTE!**  
 When used on ED-120 the pump shall be mounted with the connections pointing "up".  
 ( note necessary when the gear in the PTO has a supportbearing)

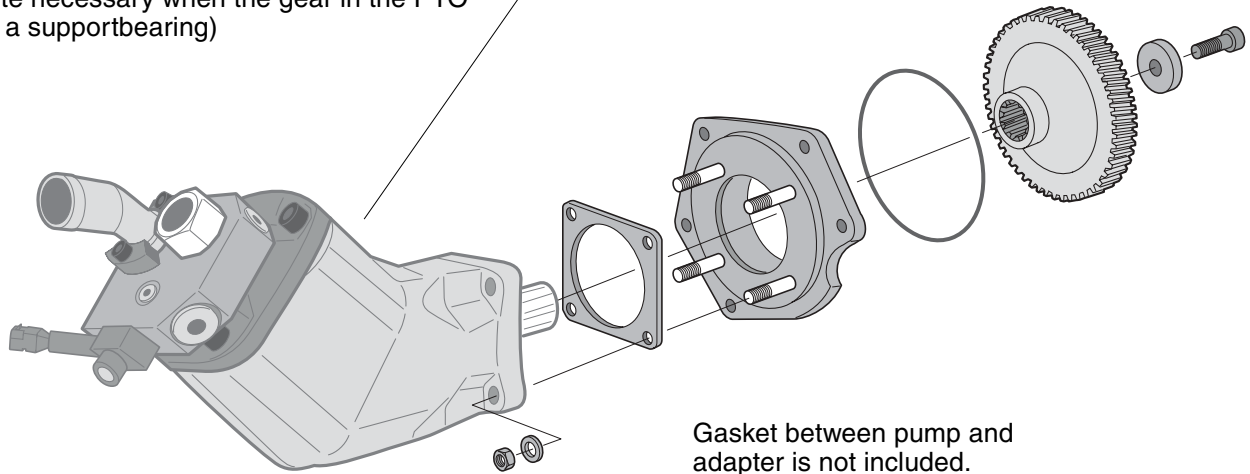

| Pump size                     | F1-25           | F1-41 | F1-51 | F1-61 | F1-81 | F1-101 | F2-53/53 | F2-70/35 |
|-------------------------------|-----------------|-------|-------|-------|-------|--------|----------|----------|
| Max. operating pressure [bar] | 350             |       |       | 350   |       |        | 350      | 350      |
| Bypass valve                  | <b>Required</b> |       |       |       |       |        |          |          |

**NOTE:** Max operating pressures shown for the F2 frame sizes are valid when both ports are pressurized to the same level simultaneously.

|                            |                        |
|----------------------------|------------------------|
| Max. torque [Nm]           | 600                    |
| Gear ratio (engine : pump) | 1 : 1.19               |
| Pump rotation              | Right hand (clockwise) |

| PTO adapter kit | Ordering number* |
|-----------------|------------------|
| ED-120-F1       | <b>378 2021</b>  |
| ED-120-VP1      | <b>378 2022</b>  |

\* Part numbers valid from 00-10-23 (W0043); replacing 379 9888 and 379 9889 respectively.

## PTO adapter kit for Scania ED 140 engines

- With the adapter kit, an hydraulic pump that meets the ISO standard can be installed on PTO of the Scania 14 liter engine DS 14.
- The PTO gear is not supplied with the kit; it must be ordered separately. For model 144 and later it can be ordered either from Parker Hannifin, ordering number 379 9413, or from Scania Spare Parts.

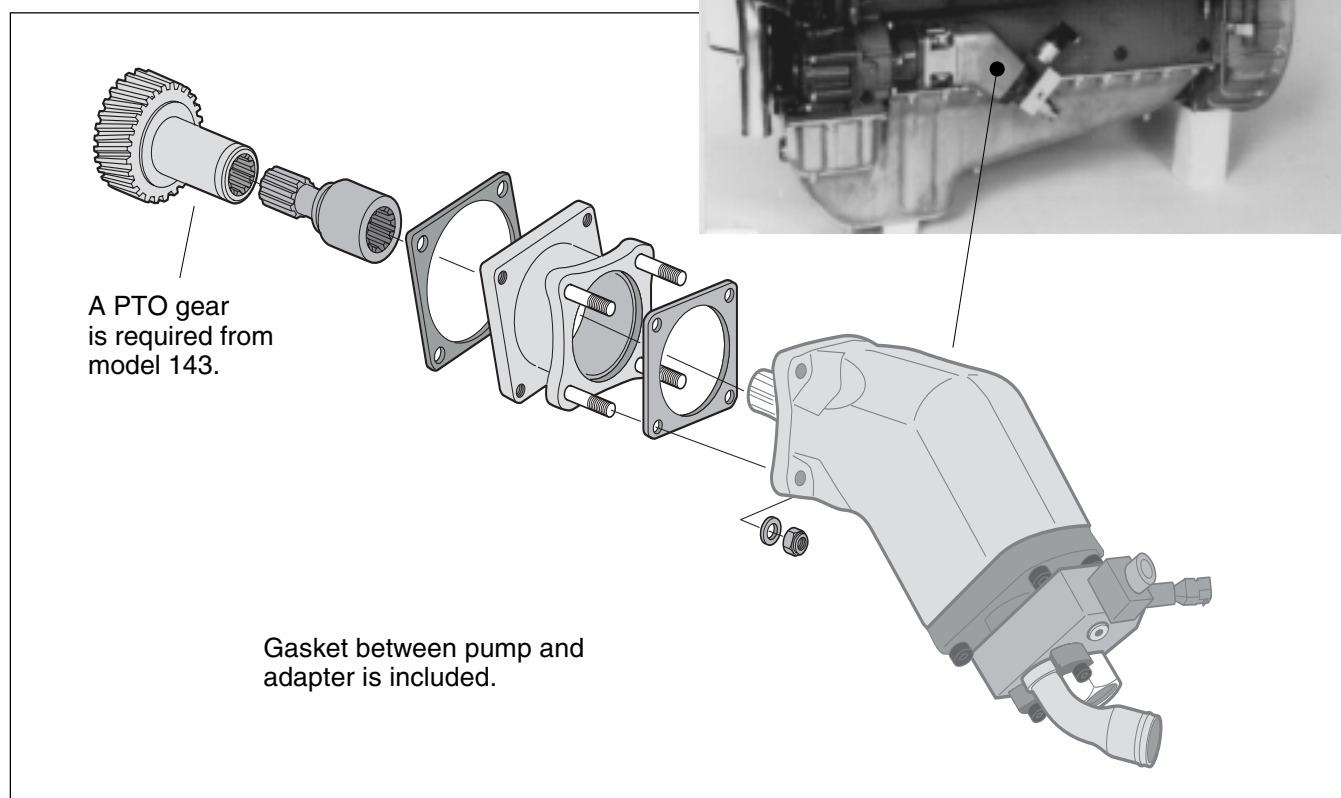
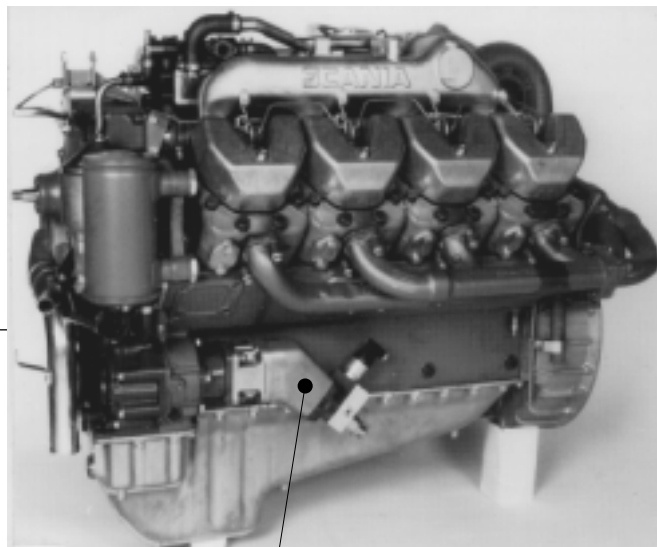

| Pump                          | F1-25           | F1-41 | F1-51 | F1-61 | F1-81 <sup>1)</sup> |
|-------------------------------|-----------------|-------|-------|-------|---------------------|
| Max. operating pressure [bar] | 350             | 350   | 285   | 200   | 150 <sup>1)</sup>   |
| Bypass valve                  | <b>Required</b> |       |       |       |                     |

1) The engine transmission permits only 150 bar on the F1-81.

|                             |                        |
|-----------------------------|------------------------|
| Max. torque [Nm]            | 186                    |
| Gear ratio (engine-to-pump) | 1 : 1                  |
| Pump rotation               | Right hand (clockwise) |

| Designation               | Ordering number |
|---------------------------|-----------------|
| ED-140 adapter kit        | <b>370 8445</b> |
| PTO gear (from model 144) | <b>379 9413</b> |

**NOTE:** Model 143 also requires a PTO gear: Scania part no. 259 206.

### PTO adapter kit for Scania ED 160 engines

- With the adapter kit, an hydraulic pump (e.g. F1 or VP1) that meets the ISO standard can be installed on the PTO of the Scania 16 liter engine.
- The PTO gear is supplied with the chassis.
- **Please note:** The engine must be ordered with a PTO.

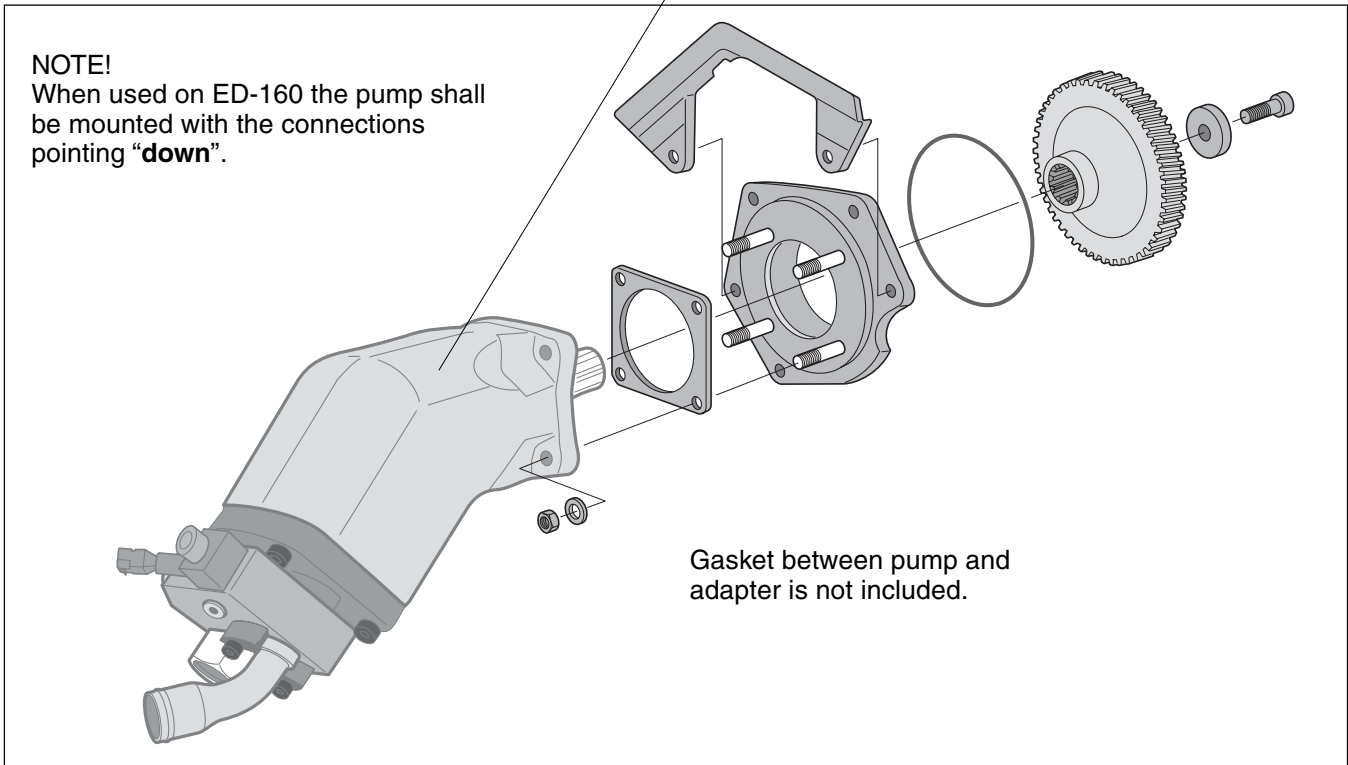

| Pump size                     | F1-25           | F1-41 | F1-51 | F1-61 | F1-81 | F1-101 | F2-53/53 | F2-70/35 |
|-------------------------------|-----------------|-------|-------|-------|-------|--------|----------|----------|
| Max. operating pressure [bar] | 350             |       |       | 350   |       |        | 350      | 350      |
| Bypass valve                  | <b>Required</b> |       |       |       |       |        |          |          |

**NOTE:** Max operating pressures shown for the F2 frame sizes are valid when both ports are pressurized to the same level simultaneously.

|                          |                               |
|--------------------------|-------------------------------|
| Max. torque [Nm]         | 600                           |
| Gear ratio (engine:pump) | 1 : 1.19                      |
| Pump rotation            | Left hand (counter clockwise) |

| PTO adapter kit | Ordering number |
|-----------------|-----------------|
| ED-160-F1       | <b>378 2001</b> |

### PTO adapter kit for Mercedes engines (Actros)

- With the adapter kit, an hydraulic pump that meets the ISO standard can be installed on the PTO of the Mercedes V6 and V8 engines.
- The PTO must be ordered with the chassis from the manufacturer or through the distributor; when ordering, state 'N53 without pump'.

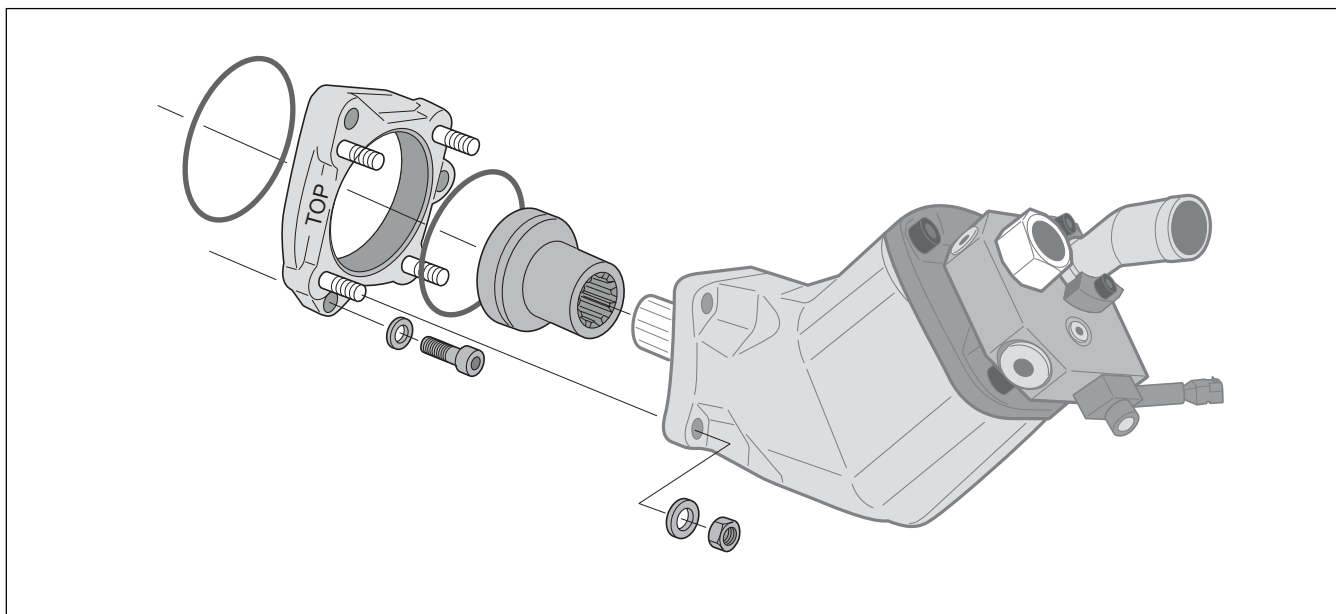

| Pump   | F1-25    | F1-41 | F1-51 | F1-61 | F1-81 | F1-101 |
|--|----------|-------|-------|-------|-------|--------|
| Max. operating pressure [bar]<br>for short duration, non-frequent work cycles<br>(e.g. tippers and skip loaders) | 350      | 350   | 350   | 350   | 350   | 270    |
| Max. operating pressure [bar]<br>for continuous work cycles<br>(e.g. cranes and winches)                         | 350      | 350   | 350   | 350   | 310   | 225    |
| Bypass valve   | Required |       |       |       |       |        |

| Pump   | F2-53/53 | F2-70/35 | VP1-045 | VP1-075 |
|--|----------|----------|---------|---------|
| Max. operating pressure [bar]<br>for short duration, non-frequent work cycles<br>(e.g. tippers and skip loaders) | 270      | 270      | 350     | 350     |
| Max. operating pressure [bar]<br>for continuous work cycles<br>(e.g. cranes and winches)                         | 230      | 230      | 300     | 300     |
| Bypass valve   | Required |          |         |         |

**NOTE:** Max operating pressures shown for the F2 frame sizes are valid when both ports are pressurized to the same level simultaneously.

|  |                        |
|--|------------------------|
| Max. non-frequent/continuous torque [Nm] | 470/390                |
| Gear ratio (engine-to-pump)              | 1 : 1.075              |
| Pump rotation                            | Right hand (clockwise) |

| Adapter kit | Ordering number |
|-------------|-----------------|
| VH-PTO-DB   | 379 2568        |

## Cardan shafts, pump couplings and mounting brackets

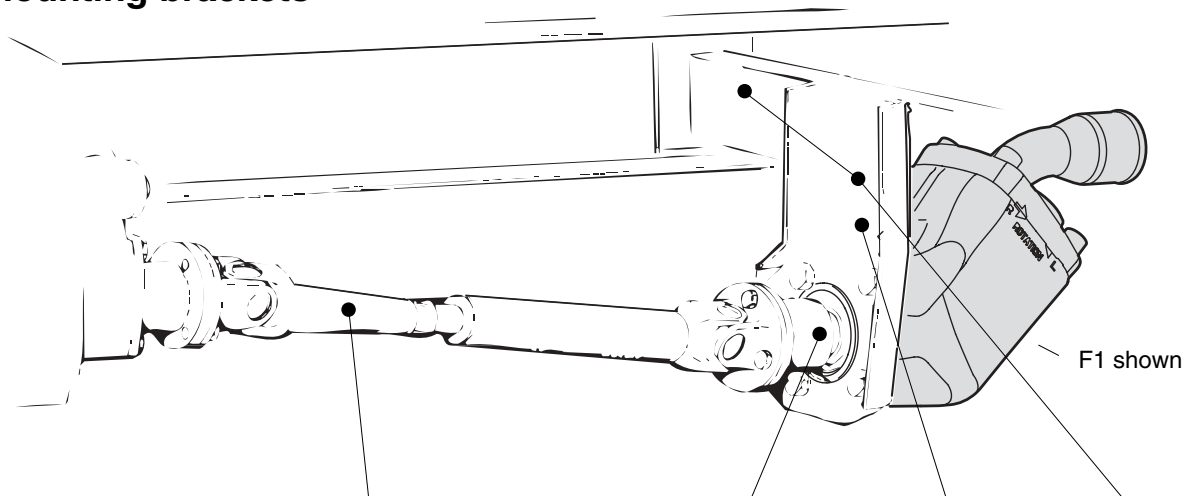

| Pump or splitter box type | Cardan shaft kit Type | Cardan shaft kit Ordering no. | Pump coupling Type   | Pump coupling Ordering no.    | Bracket ordering no. | Bracket kit ordering no. |
|---------------------------|-----------------------|-------------------------------|----------------------|-------------------------------|----------------------|--------------------------|
| F1 <sup>1)</sup>          | SAE 88 <sup>1)</sup>  | <b>073 001</b>                | SAE 88 <sup>1)</sup> | <b>370 4628</b>               | <b>379 7831</b>      | <b>379 7832</b>          |
| F1 (New)                  | "                     | "                             | "                    | <b>378 0644</b>               | "                    | "                        |
| F1 (New)                  | SAE 97                | <b>370 0315</b>               | SAE 97               | <b>378 0645</b>               | <b>379 7831</b>      | <b>379 7832</b>          |
| F1                        | "                     | "                             | "                    | <b>370 4631</b>               | "                    | "                        |
| F2                        | "                     | "                             | "                    | "                             | "                    | "                        |
| T1-51                     | "                     | "                             | "                    | "                             | "                    | "                        |
| VP1                       | "                     | "                             | "                    | "                             | "                    | "                        |
| SB154, SB118              | SAE 97                | <b>370 0315</b>               | SAE 97/<br>DIN 90    | Included with<br>splitter box | <b>370 5221</b>      | <b>370 5220</b>          |

1) The SAE 88 cardan shaft and pump coupling can also be used to drive a series F2, T1-51 or VP1 pump providing max allowed shaft torque (below) is not exceeded.

### Cardan shaft specifications

| Cardan shaft type | Spicer designation | Max length [mm]    | Diameter [mm] | Max torque peak/contin. [Nm] | Ordering number |
|-------------------|--------------------|--------------------|---------------|------------------------------|-----------------|
| SAE 88            | K1140              | 1220 <sup>2)</sup> | 45            | 600/300                      | <b>073 001</b>  |
| SAE 97            | K1310              | 1220 <sup>2)</sup> | 50            | 1000/500                     | <b>370 0315</b> |

2) One end not welded

### PTO flange adapters

| Cardan shaft type | PTO flange type | Flange adapter ordering no.  |
|-------------------|-----------------|------------------------------|
| SAE 88            | SAE 116         | <b>370 5895</b>              |
| SAE 97            | SAE 116         | <b>370 5896</b>              |
| SAE 116           | SAE 97          | <b>370 5897<sup>3)</sup></b> |
| DIN 90            | DIN 100         | <b>370 5898</b>              |
| DIN 100           | DIN 90          | <b>370 5899<sup>3)</sup></b> |

3) **WARNING!** The utilized cardan shaft torque limits (above) must not be exceeded.

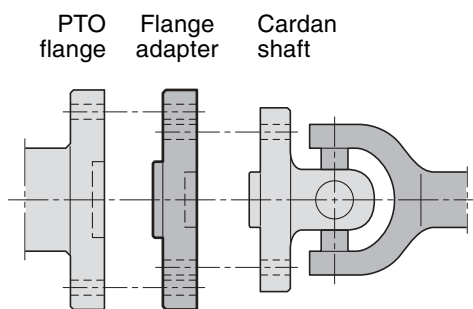

**Pump couplings**

|                |                        |
|----------------|------------------------|
| Designation    | <b>DIN 90 (fig. 1)</b> |
| A              | 90                     |
| B              | 74.5                   |
| C              | 47 h7                  |
| D              | M8                     |
| E <sub>1</sub> | 61.5                   |
| VP1, F2, F1*   | <b>370 4634</b>        |
| F1             | <b>378 0642</b>        |

**NOTE:** Max torque is limited by the cardan shaft.

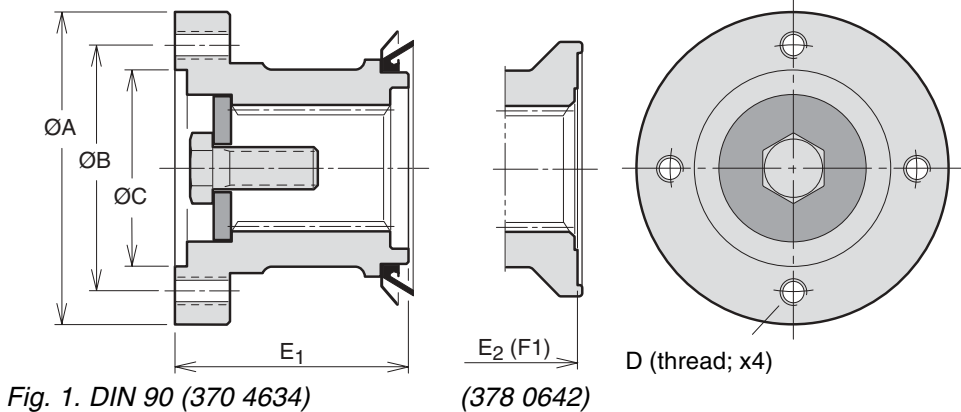

Fig. 1. DIN 90 (370 4634)

(378 0642)

|                     |                        |
|---------------------|------------------------|
| Designation         | <b>DIN 90 (fig. 2)</b> |
| A                   | 90                     |
| B                   | 74.5                   |
| C                   | 47 h7                  |
| D                   | 8.2                    |
| E <sub>1</sub>      | 61.5                   |
| E <sub>2</sub> (F1) | 57.2                   |
| VP1, F2, F1*        | <b>370 7423</b>        |

**NOTE:** Max torque is limited by the cardan shaft.

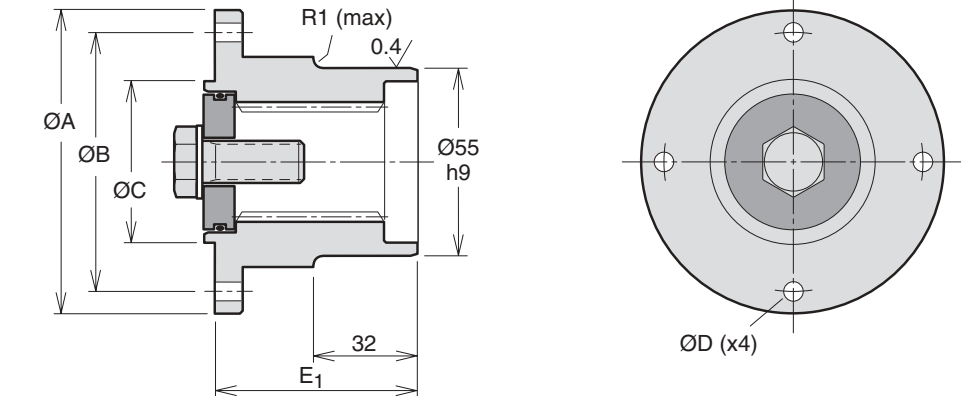

Fig. 2. DIN 90 (370 7423)

|                                    |                       |
|------------------------------------|-----------------------|
| Designation                        | <b>SAE88 (fig. 3)</b> |
| A                                  | 88                    |
| B                                  | 69.9                  |
| C                                  | 57.15 H8              |
| D                                  | 5/16" UNC             |
| E <sub>1</sub>                     | 65                    |
| E <sub>2</sub> (F1)                | 59.5                  |
| Max torque [Nm]<br>interm./contin. | 600/300               |
| VP1, F2, F1*                       | <b>370 4628</b>       |
| F1                                 | <b>378 0644</b>       |

**NOTE:** Max torque is limited by the cardan shaft.

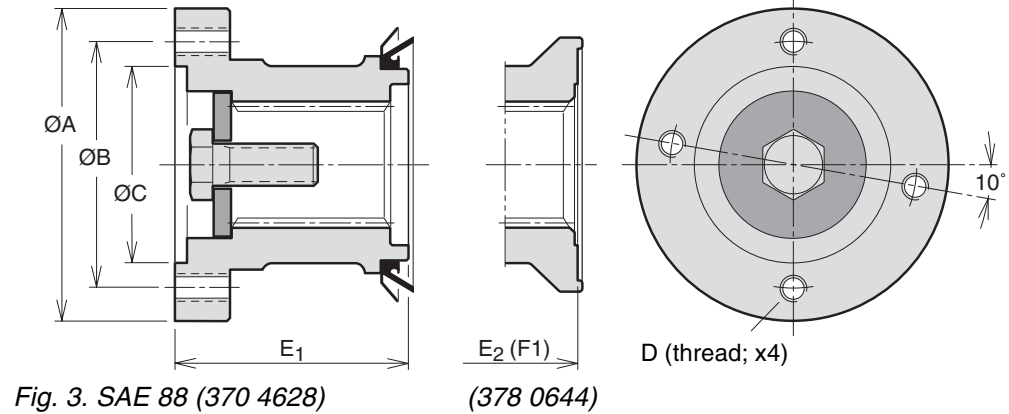

Fig. 3. SAE 88 (370 4628)

(378 0644)

|                                    |                       |
|------------------------------------|-----------------------|
| Designation                        | <b>SAE97 (fig. 4)</b> |
| A                                  | 97                    |
| B                                  | 79.4                  |
| C                                  | 60.33 H8              |
| D                                  | 3/8" UNC              |
| E <sub>1</sub>                     | 65                    |
| E <sub>2</sub> (F1)                | 59.5                  |
| Max torque [Nm]<br>interm./contin. | 1000/500              |
| VP1, F2, F1*                       | <b>370 4631</b>       |
| F1                                 | <b>378 0645</b>       |

F1\* Old versions

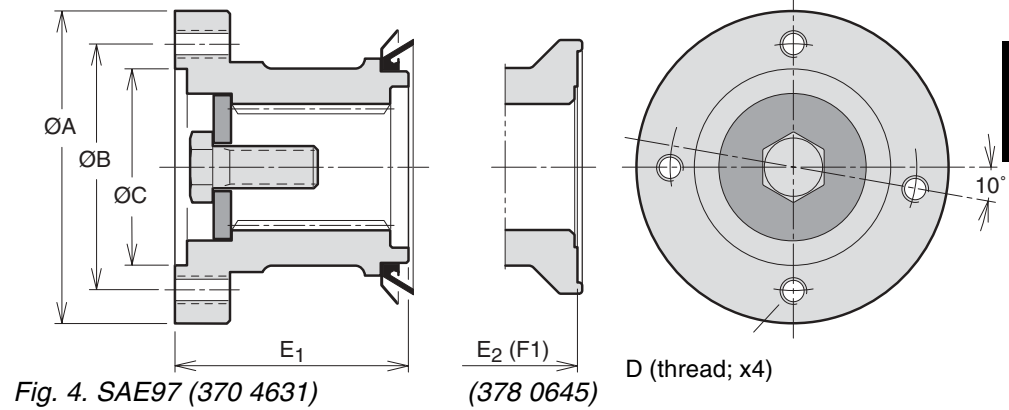

Fig. 4. SAE97 (370 4631)

(378 0645)

## Return filter and filter indicator

### Return flow filter

The low pressure, full flow return filter contains a replaceable fiber glass cartridge with a large flow area. The filter is designed for vertical installation on top of the hydraulic reservoir.

The built-in bypass function opens at 1.6 bar; the overflow is above the cartridge, preventing accumulated dirt inside the filter to enter the flow.

The aluminum housing contains three BSP 1/8" ports which can be utilized for the installation of a filter indicator (see below).

| Designation  | Return filter  |
|--|----------------|
| Rated flow (at 30 cSt) [l/min]   | 230            |
| Cartridge pressure drop at rated flow and 30 cSt [bar]                     | < 0.1          |
| Degree of filtration ( $\beta_{25} \cdot 75$ , ISO 4572) [ $\mu\text{m}$ ] | 20 (abs.)      |
| Cartridge collapse rating (ISO 2941) [bar]                                 | 8              |
| Inlet port size  | BSP 1 1/4"     |
| Weight incl. cartridge [kg]  | 6              |
| Ordering code, filter ass'y  | <b>946 395</b> |
| filter cartridge only  | <b>946 396</b> |

**NOTE:** The flow capacity of the filter should be at least twice the pump flow under normal operating conditions.

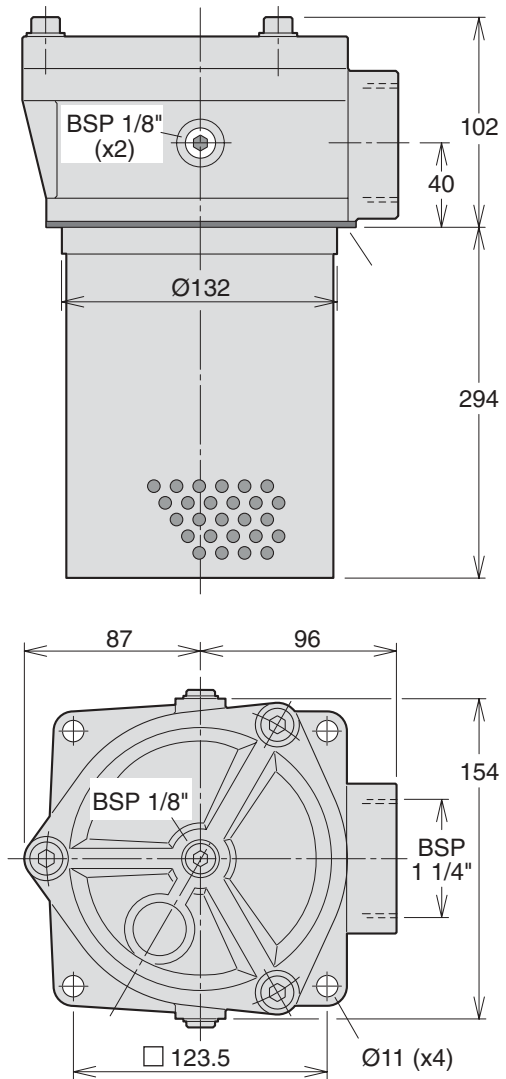

### Filter indicator

The visual filter indicator installs in one of the filter housing ports (BSP 1/8"; see above). When the hydraulic system has reached normal operating temperature, the position of the indicator needle shows the condition of the filter cartridge:

- 'Green' - The cartridge is OK.
- 'Red' - Replace the cartridge.

**NOTE:** A needle in the red area indicates that only part of the oil flow is being filtered which, in turn, means that system components such as the pump will suffer from increased wear.

| Designation                  | Filter indicator |
|------------------------------|------------------|
| 'Green' pressure range [bar] | - 1.0            |
| 'Red' pressure range [bar]   | 1.0 – 1.6        |
| Max pressure (peak) [bar]    | 2.5              |
| Installation thread          | BSP 1/8"         |
| Ordering number              | <b>378 0191</b>  |

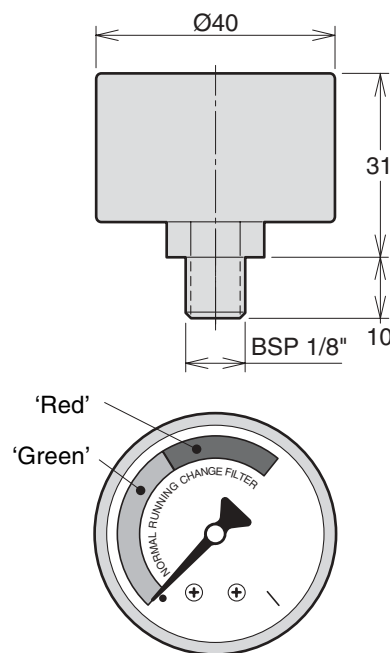



## Air breather filter

The oil level in the reservoir can sink drastically when max pump capacity is utilized e.g. to fill the piston end of a cylinder with a large 'piston/piston rod' ratio and the return flow back to tank is comparatively small. A corresponding volume of air must then enter the tank through the breather.

The air breather shown to the right, which mounts on top of the reservoir, is adequately dimensioned for most applications. It has sufficient filtering properties to prevent external dirt from entering the hydraulic system.

The breather has a built-in function which limits the tank pressure to 0.5 bar.

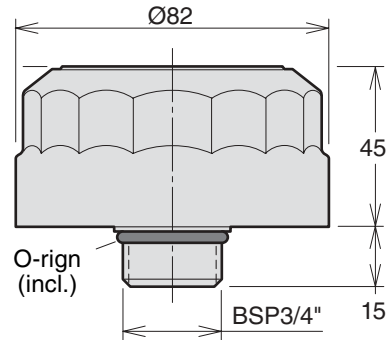

| Designation                                    | Air filter      |
|--|-----------------|
| Nominal air flow [l/min]                       | 300             |
| Nominal degree of filtration [ $\mu\text{m}$ ] | 6               |
| Exhaust opening pressure [bar]                 | 0.5             |
| Installation thread                            | BSP 3/4"        |
| Ordering number                                | <b>378 0190</b> |

**NOTE:** Preferably, the air flow capacity should be at least twice the pump flow under normal operating conditions.

## Check valves

| Check valve | Ordering number | Max flow [l/min] | Max press. [bar] | Opening press. [bar] |
|-------------|-----------------|------------------|------------------|----------------------|
| 1/2"        | <b>379 1963</b> | 75               | 350              | 0,5                  |
| 3/4"        | <b>379 1964</b> | 130              | 350              | 0,5                  |
| 1"          | <b>379 1965</b> | 200              | 350              | 0,5                  |

| Check valve | Dimensions in mm; B and C threads are BSP. |      |      |          |    |    |    |
|-------------|--|------|------|----------|----|----|----|
|             | A  | B    | C    | $\phi$ D | E  | F  | G  |
| 1/2"        | 32   | 1/2" | 1/2" | 30       | 19 | 35 | 69 |
| 3/4"        | 36   | 3/4" | 3/4" | 34       | 20 | 13 | 65 |
| 1"          | 40   | 1"   | 1"   | 43       | 20 | 15 | 70 |

**NOTE:** Free flow is indicated by the arrow.

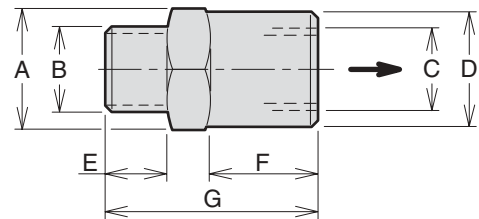

1/2" check valve

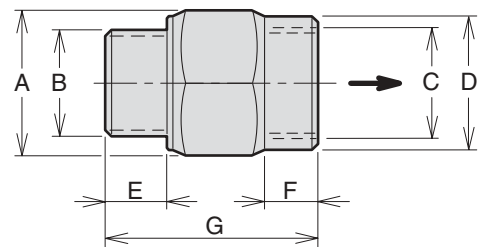

3/4" check valve

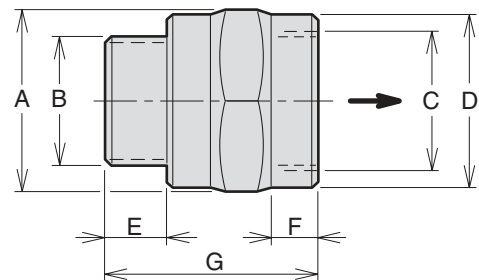

1" check valve

### SB splitter boxes

- The splitter box is utilized to drive two pumps, providing two separate, independent flows.
- The high permissible input shaft torque allows two large pumps to be operated simultaneously; make sure, however, that the PTO and the cardan shaft will stand the intended load.
- Pump mounting flange and shaft end must meet the ISO standard.
- The splitter box is available with either of two gear ratios (input shaft-to-pump):

**SB 118** - 1:1.18

**SB 154** - 1:1.54

- The shipping carton contains all parts required for the installation of the two pumps.

### Recommendations

Use the following tables to verify that max pump rpm and max splitter box input torque are not exceeded.

| Pump size | Max input speed [rpm] |        |
|-----------|-----------------------|--------|
|           | SB 118                | SB 154 |
| F1-20     | 1950                  | 1500   |
| F1-30     | 1700                  | 1300   |
| F1-40     | 1525                  | 1200   |
| F1-60     | 1300                  | 975    |
| F1-80     | 1100                  | 850    |
| F1-110    | 1100                  | 850    |
| T1-50     | 1350                  | 1000   |

Example: An SB 118 with an F1-20 and an F1-80 can be operated at max 1100 rpm (splitter box input speed), and an SB 154 with the same pumps at max 850 rpm.

| Pump size | Pump input torque [Nm] at |         |         |
|-----------|---------------------------|---------|---------|
|           | 250 bar                   | 300 bar | 350 bar |
| F1-20     | 80                        | 95      | 110     |
| F1-30     | 120                       | 140     | 165     |
| F1-40     | 160                       | 190     | 225     |
| F1-60     | 240                       | 285     | 335     |
| F1-80     | 315                       | 380     | 445     |
| F1-110    | 435                       | 525     | 610     |
| T1-50     | 200                       | 240     | 275     |
| F2-53/53  | 420                       | 505     | 590     |
| F2-70/40  | 435                       | 525     | 610     |

Example: An F1-40 at 350 bar requires 225 Nm and an F1-60 at 300 bar 285 Nm.

Total required splitter box input torque:

**SB 118:** (225 + 285) x 1.18 ≈ 610 Nm.

**SB 154:** (225 + 285) x 1.54 ≈ 785 Nm

Compare with max permissible torque (interm. 1000 Nm; continuous 700 Nm).

**NOTE:** If the splitter box should be utilized at close to the max permissible torque and/or max the permissible speed, please contact Parker Hannifin

### Installation information

#### 1. Series F1, T1 and F1 (fig. 2)

Valid: At continuous operation less than 30 min. and/or less than 80 kW continuous power output.

- Remove the uppermost drain plug and add 0.5 liter Shell Spirax AX (or similar fluid).
- Install the breather (and the 90° adapter, part no. 378 1069, if required).

**NOTE:** The F1 or T1 shaft seal **must not** be removed.

#### 2. Series F1 and T1 (left illustration, fig. 3)

Valid: At continuous operation more than 30 min. and/or more than 80 kW continuous power output.

- Remove the shaft seals.
- Install a drain hose between the drain port on the side of the splitter box (see the illustr.) and the reservoir; it must end below the lowest oil level in the reservoir. Utilize one of the 'banjo' couplings included in hose kit 378 1085.

#### 3. Series F1 (right illustration, fig. 3)

Valid: At continuous operation more than 30 min. and/or more than 80 kW continuous power output.

- Install hose kit 378 1085 between the lowest drain port on one of the pumps (see fig. 3) and the BPV-F1-25 och -81 avlastningsventiler lowest drain port of the splitter box.
- Install a drain hose between the drain port on the side of the splitter box and the reservoir; it must end below the lowest oil level in the reservoir. Utilize one of the banjo couplings included in hose kit 378 1085.

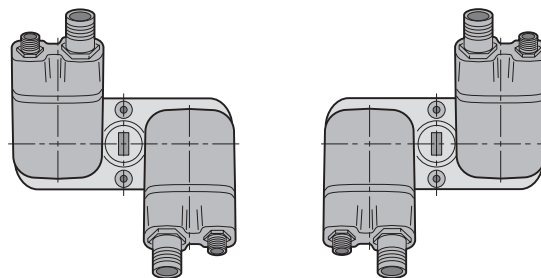

**NOTE:** The inlet (suction) ports of the pumps should always face the splitter box center, as shown, in order to counteract internal gear forces.

Fig. 1. F1-pumps installed on a splitter box.

| Designation                                   | SB 118   | SB 154          |
|---|--|-----------------|
| Gear ratio (inp. shaft-to-pump)               | 1:1.18   | 1:1.54          |
| Max input torque intermittent/continuous [Nm] | — 1000/700 —                                   |                 |
| Max power                                     | Housing oil temperature must not exceed 75 °C. |                 |
| Weight [kg]                                   | — 11.5 —                                       |                 |
| Ordering number                               | <b>379 4981</b>                                | <b>370 5100</b> |

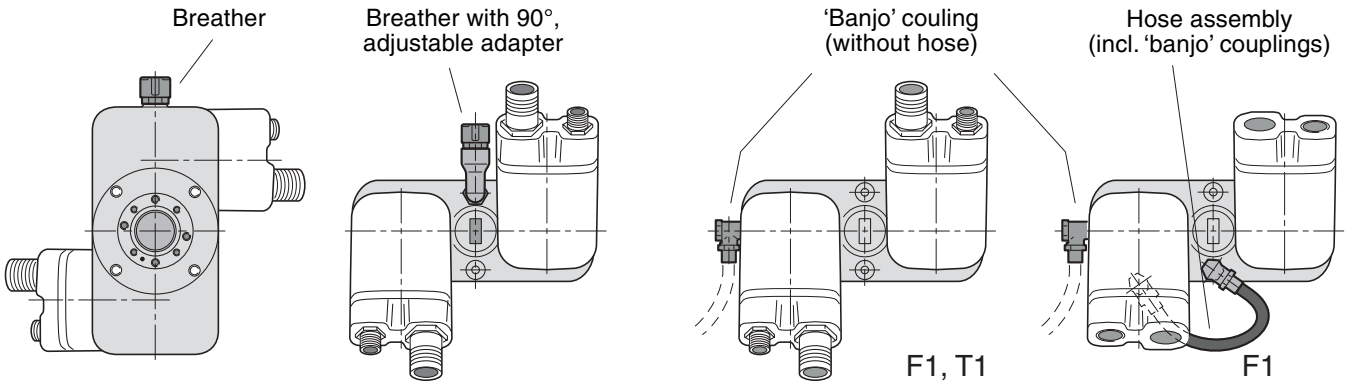

Breather kit (incl. 90°, adjustable adapter and seals):  
 Part no. 378 1069.

Fig. 2. Breather installation on the splitter box.

Hose kit (hose sub-ass'y and separate 'banjo' coupling):  
 Part no. 378 1085.

Fig. 3. Forced cooling of the splitter box.

**Splitter box installation**

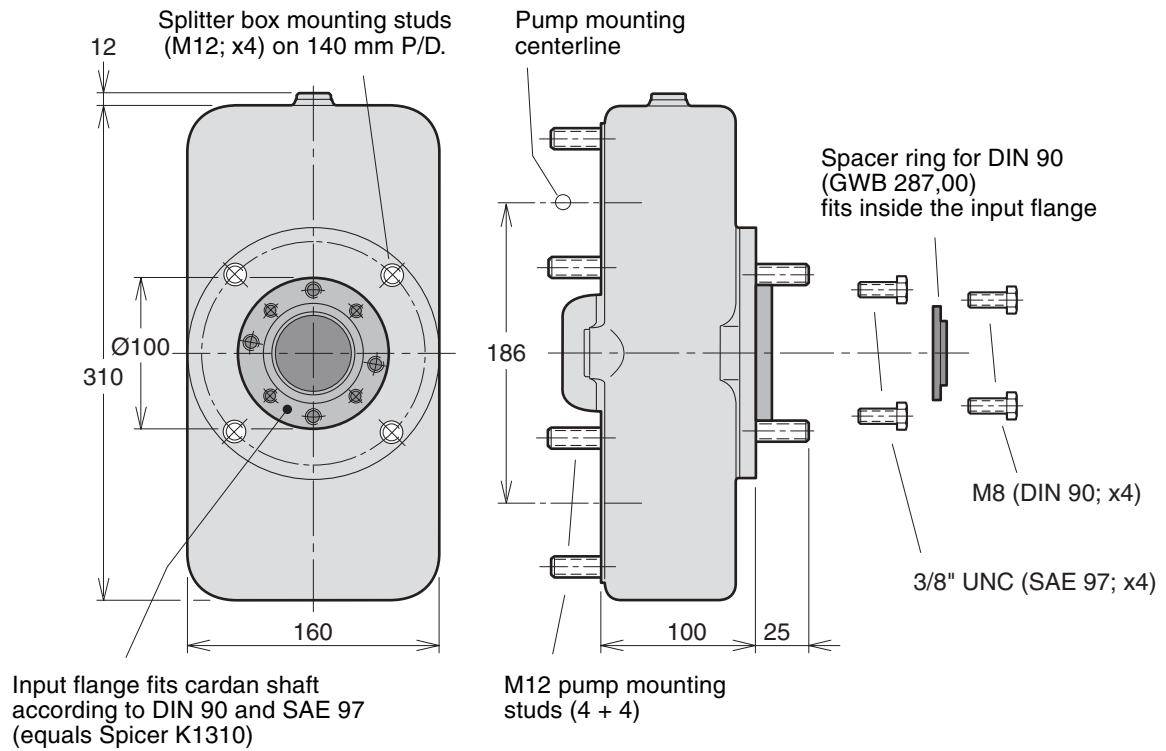

# Installation and start up

Installing couplings, sleeves, and gears on the pump shaft.

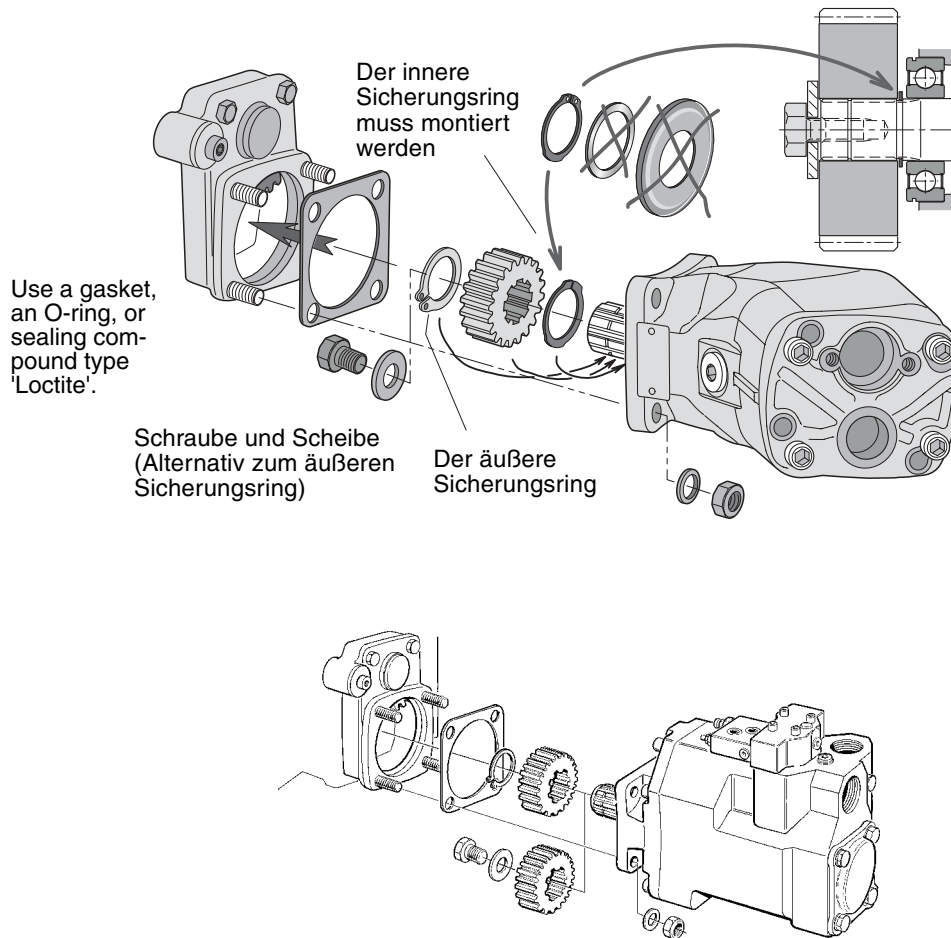

Fig. 6. VP1-to-PTO installation.

## IMPORTANT

Our special tool (part no. 370 6851) facilitates installing couplings, sleeves, and gears on the pump shaft. Force must never be used when installing these parts on the F1 shaft.

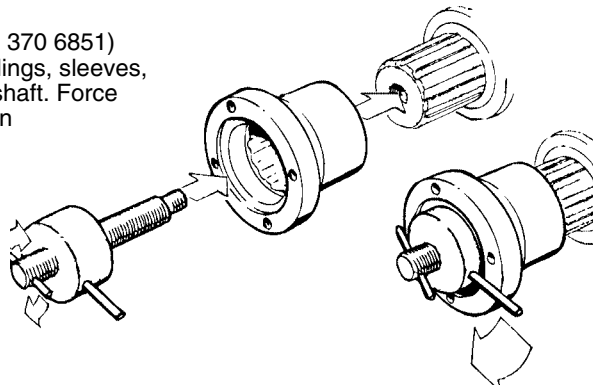
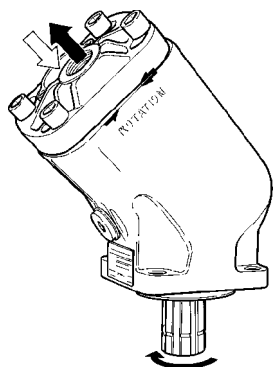

Fig. 7 Mounting tool.

**NOTE:** When considering installing an F1 on a splitter box, please refer to the installation information provided on pages 58- 59, chapter 11.

## Installation and start-up for F1, F2 and T1



Left hand (L.H.; counter clockwise) rotating pump.

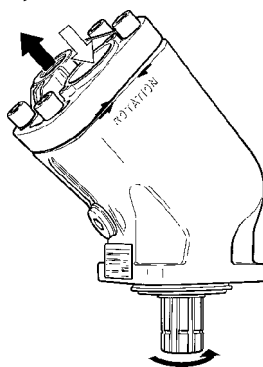

Right hand (R.H.; clockwise) rotating pump.

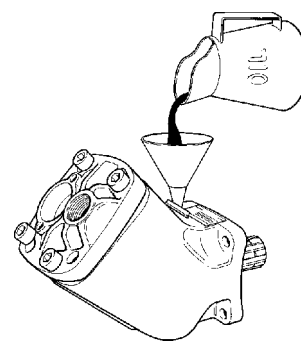

Before start-up, the housing must be filled with hydraulic fluid.

### Direction of rotation

The pictures above show direction of flow vs. shaft rotation.

The direction of rotation can be changed (i. e. from right hand to left hand) by turning the end cap.

Remove the four cap screws and turn the end cap about half a turn while making sure it stays in contact with the barrel housing.

Re-fit the cap screws and torque to 80-100 Nm.

### Installation

The robust shaft bearings allow the fixed displacement pumps to be mounted either on a bracket, driven by a belt or a cardan shaft, or directly on a PTO.

The top illustration on page 60 shows two ways of installing a gear on the shaft of fixed displacement pumps. The pump shaft spline end usually fits directly in the PTO internal spline coupling.

**NOTE:** In order to obtain the longest bearing life, the pump should be installed according to the information shown on page 62 "Pump bearing life".

### Fluid viscosity

Recommended viscosity:  
20 to 30 mm<sup>2</sup>/s (cSt).

Operating viscosity limits:

- Min 10 mm<sup>2</sup>/s; max 400 mm<sup>2</sup>/s.
- At start-up, max 4000 mm<sup>2</sup>/s.

### Fluids

The fixed displacement pumps data shown in the specifications for each pump in chapter 3 to 6 are valid when operating on high quality, mineral based hydraulic oil. Type HLP (according to DIN 51524) hydraulic oil is suitable as well as biologically degradable fluids like natural and synthetic esters and polyalphaolefins.

The utilized hydraulic fluid shall meet one of the following Swedish standards:

- SS 15 54 34
  - SMR Hydraulic Oil Standard 1996-2.
- Contact Parker Hannifin (Mobile Controls Div.) for further information.

**NOTE:** - ATF (automatic transmission fluid) and API type CD engine oils may also be useable.

- Seals are made of nitrile rubber; make sure the utilized fluid is compatible with this material.

### Fluid temperature

Main circuit: Max 75 °C.

### Drain line

Fixed displacement pumps don't need an external drain line as they are internally drained.

### Filtration

Filtration should follow ISO standard 4406, code 18/13.

To obtain the longest life of fixed displacement pumps, we recommend an oil cleanliness of 10 µm (absolute).

### Start-up

Make sure the entire hydraulic system is clean before filling it with a recommended hydraulic fluid. In particular, make sure the pump is filled (to at least 50%) as the internal leakage does not provide sufficient lubrication at start-up.

**NOTE:** - The suction port should always be above the pressure port when the pump is installed above the reservoir oil level.

- During operation, the pump must be filled with oil to at least 50%.

**NOTE:** When considering installing an fixed displacement pump on a splitter box, please refer to the installation information provided on pages 58 and 59, chapter 11.

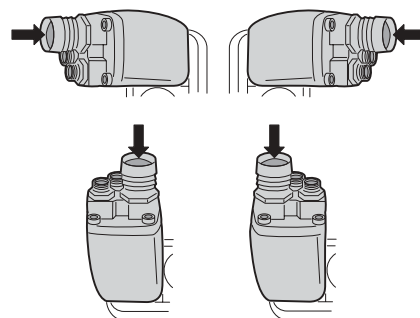

**T1-to-PTO installation**

- 'Left hand' and 'Right hand' rotation defined in the illustrations on page 61.

- The driving gear of the PTO and the driven gear of the pump are shown in the illustration below. (A right hand rotating pump is shown).

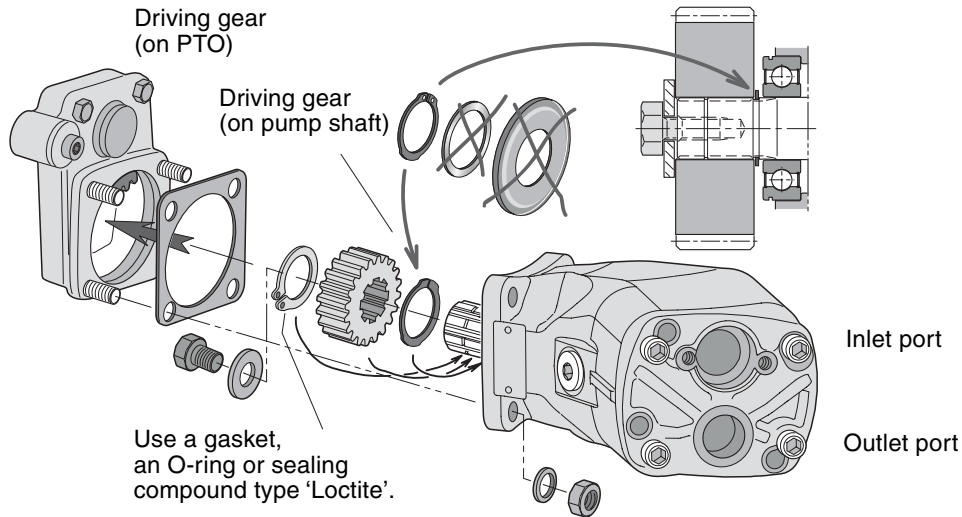

**Pump bearing life**

Bearing life is dependent on how the pump is installed on the PTO as shown in the illustrations below.

A pump mounted according to fig. 1 gives the lowest bearing life; the highest is obtained when installed according to fig. 3.

Parker Hannifin will assist in determining bearing life in a particular application.

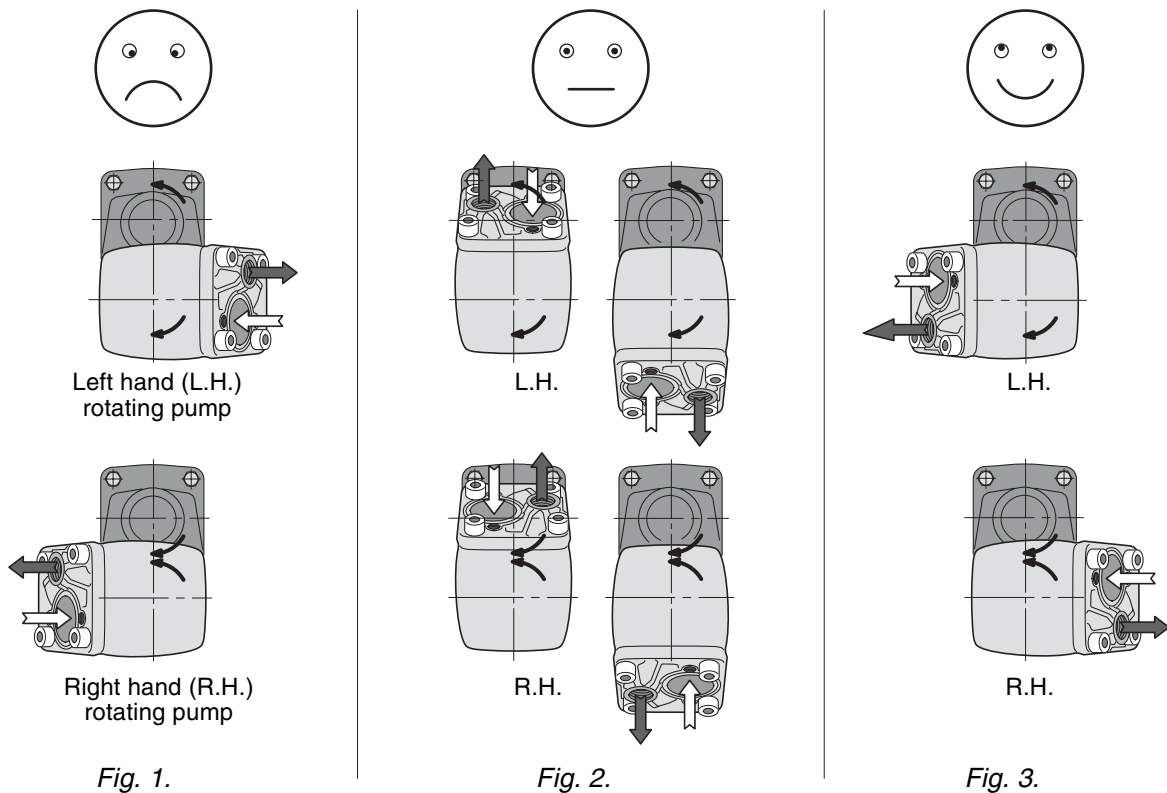

## Installation and start-up for VP1

### Direction of rotation

The basic VP1 pump is uni-directional; there is a left hand and a right hand version (indicated by the arrow on the side of the VP1 pump (fig. 4 and 5). Consequently, the required direction of rotation must be stated when ordering the pump.

### Installation

The VP1 can be installed (close-coupled) directly on a PTO (which meets ISO DIN 5462). Before start-up, the pump must be filled with hydraulic fluid and purged. Utilize the uppermost purge plug (refer to the installation drawing on page 32, chapter 7). Figure 6 shows two ways of installing a gear on the VP1 shaft. On a non-geared or a geared PTO with support bearings, the pump shaft is usually installed directly in the internally splined PTO output shaft.

### Hydraulic fluids

The VP1 data shown in the specifications on page 31, chapter 7 are valid when operating on a high quality, mineral based fluid. Hydraulic fluids type HLP (DIN 51524), ATF (automatic transmission fluids), and API type CD engine oils are suitable.

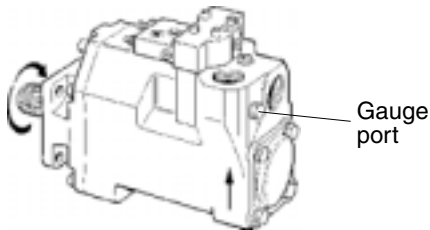

Fig. 4. Left hand rotating pump.

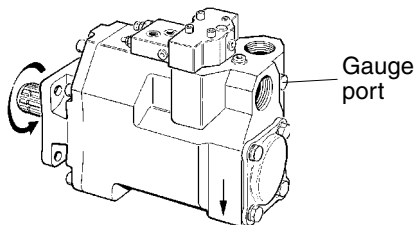

Fig. 5. Right hand rotating pump.

### Fluid temperature

Main circuit: Max 75 °C.

### Viscosity

Recommended viscosity: 20 to 30 mm<sup>2</sup>/s (cSt).  
Operating viscosity limits: 10 - 400 mm<sup>2</sup>/s.  
At start-up: Max 1000 mm<sup>2</sup>/s.

### Filtration

To obtain long VP1 life, we recommend a filtration level of:

- 25 µm (absolute) in clean environment or at low pressures.
- 10 µm (absolute) in contaminated environment or at high pressures.

Filtration should meet ISO standard 4406, code 18/13.

### Drain line

The LS valve *requires a separate drain line*; it should be routed directly to the reservoir (refer to fig. 8).

### Start-up

Make sure the entire hydraulic system is clean before filling it with a recommended fluid. In addition, the VP1 pump must be purged to remove any entrapped air in the pump housing; utilize the uppermost purge port (fig. 8).

### IMPORTANT

As shown in fig. 8, the pump inlet must always be below the lowest reservoir oil level.

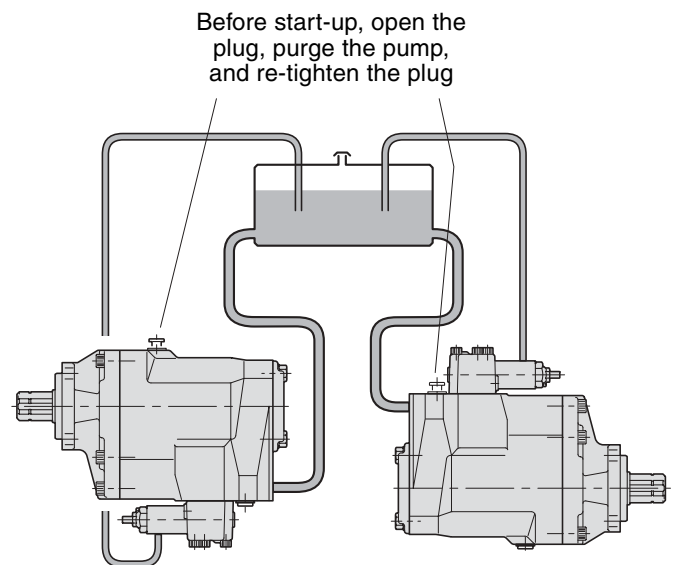

Fig. 8. VP1 should be installed below the reservoir fluid level.

*Purging should be performed when the pump is connected to the reservoir and the system is filled with fluid.*

## Parker PTO's

Parker's power take-off units are designed to meet the requirement of the majority of today's truck applications. The PTO range covers a great many European trucks and is being continually updated to fit new gearboxes. The PTO's are used in a variety of applications such as Tippers, Hook Loaders, Skip Loaders and Cranes, and are specifically designed to close-couple pumps with the current ISO-Standard mounting flange. Alternatively, the units can be fitted with our cardan shaft adaptor to enable them to be used for a wide range of propshaft driven applications.

- Tailor made for the Parker Truck Hydraulics pumps Possibility to close-couple any ISO-standard pump
- Shaft-driven adaptor for other applications Competitively priced
- Easy to install
- Electrical indicator available on latest PTO's.

Parker can, with its range of PTO units, the F1, F2, T1 and VP1 truck pumps, and a great number of accessories, offer the total truck hydraulic package. Parker have in Europe become synonymous for extraordinary quality. Many body builders and chassis manufacturers now include our products as a standard part of their programme."

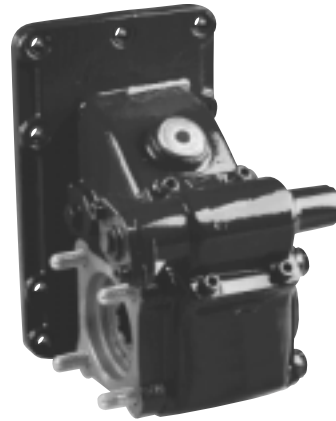

SCANIA



VOLVO



ZF



## PTO's from Parker Chelsea

### A comprehensive range

Parker Chelsea PTO's are designed to offer more output and shaft options than any other manufacturer, to ensure total compatibility no matter what the vehicle or application. A large percentage of the world's major OEM and transmission manufacturers and bodybuilders depend upon PTO's and auxiliary power products from Parker Chelsea for applications such as trucks, refuse vehicles, fire tenders, construction vehicles like backhoe loaders, excavators, tele handlers, etc. Close coupled pumps are another important accommodation where Chelsea outputs meet both SAE and DIN standards.

# CHELSEA®



### 660 Series PTO

Heavy duty 6-bolt PTO to suit most popular transmission types. Intermittent torque rating up to 500 Nm.



### 880/885 Series PTO

Heavy duty 8-bolt PTO's available with air shift, hotshift and constant mesh options. Intermittent torque rating up to 678 Nm.



### 236 Series PTO

'Air/Hotshift' PTO for medium and heavy duty transmissions. Intermittent torque rating up to 406 Nm.





## **WARNING**

**FAILURE OR IMPROPER SELECTION OR IMPROPER USE OF THE PRODUCTS AND/OR SYSTEMS DESCRIBED HEREIN OR RELATED ITEMS CAN CAUSE DEATH, PERSONAL INJURY AND PROPERTY DAMAGE.**

This document and other information from Parker Hannifin Corporation, its subsidiaries and authorized distributors provide product and/or system options for further investigation by users having technical expertise. It is important that you analyze all aspects of your application, including consequences of any failure, and review the information concerning the product or system in the current product catalogue. Due to the variety of operating conditions and applications for these products or systems, the user, through its own analysis and testing, is solely responsible for making the final selection of the products and systems and assuring that all performance, safety and warning requirements of the application are met.

The products described herein, including without limitation, product features, specifications, designs, availability and pricing, are subject to change by Parker Hannifin Corporation and its subsidiaries at any time without notice.

## **Offer of Sale**

Please contact your Parker representation for a detailed "Offer of Sale".

# Hydraulics Group Sales Offices

## Europe

**Austria**  
**Wiener Neustadt**  
Tel: +43 (0)2622 23501  
Fax: +43 (0)2622 66212

**Belgium**  
**Nivelles**  
Tel: +32 (0)67 280 900  
Fax: +32 (0)67 280 999

**Czech Republic**  
**Prague**  
Tel: +420 2 830 85 221  
Fax: +420 2 830 85 360

**Denmark**  
**Ballerup**  
Tel: +45 4356 0400  
Fax: +45 4373 8431

**Finland**  
**Vantaa**  
Tel: +358 (0)9 4767 31  
Fax: +358 (0)9 4767 3200

**France**  
**Contamine-sur-Arve**  
Tel: +33 (0)450 25 80 25  
Fax: +33 (0)450 03 67 37

**Germany**  
**Kaarst**  
Tel: +49 (0)2131 4016 0  
Fax: +49 (0)2131 4016 9199

**Hungary**  
**Budapest**  
Tel: +36 (06)1 220 4155  
Fax: +36 (06)1 422 1525

**Ireland**  
**Dublin**  
Tel: +353 (0)1 293 9999  
Fax: +353 (0)1 293 9900

**Italy**  
**Corsico (MI)**  
Tel: +39 02 45 19 21  
Fax: +39 02 4 47 93 40

**The Netherlands**  
**Oldenzaal**  
Tel: +31 (0)541 585000  
Fax: +31 (0)541 585459

**Norway**  
**Ski**  
Tel: +47 64 91 10 00  
Fax: +47 64 91 10 90

**Poland**  
**Warsaw**  
Tel: +48 (0)22 863 49 42  
Fax: +48 (0)22 863 49 44

**Portugal**  
**Leca da Palmeira**  
Tel: +351 22 9997 360  
Fax: +351 22 9961 527

**Slovakia**  
*Ref. Czech Republic*

**Spain**  
**Madrid**  
Tel: +34 91 675 73 00  
Fax: +34 91 675 77 11

**Sweden**  
**Spånga**  
Tel: +46 (0)8 597 950 00  
Fax: +46 (0)8 597 951 10

**United Kingdom**  
**Warwick**  
Tel: +44 (0)1926 317 878  
Fax: +44 (0)1926 317 855

## International

**Australia**  
**Castle Hill**  
Tel: +61 (0)2-9634 7777  
Fax: +61 (0)2-9899 6184

**Canada**  
**Milton, Ontario**  
Tel: +1 905-693-3000  
Fax: +1 905-876-0788

**China**  
**Beijing**  
Tel: +86 10 6561 0520  
Fax: +86 10 6561 0526

**Asia Pacific Group**  
**Hong Kong, Kowloon**  
Tel: +852 2428 8008  
Fax: +852 2425 6896

**India**  
**Mumbai**  
Tel: +91 22 7907081  
Fax: +91 22 7907080

**Japan**  
**Tokyo**  
Tel: +(81) 3 6408 3900  
Fax: +(81) 3 5449 7201

**Latin America Group**  
**Brazil**  
Tel: +55 12 3954-5100  
Fax: +55 12 3954-5266

**South Africa**  
**Kempton Park**  
Tel: +27 (0)11-961 0700  
Fax: +27 (0)11-392 7213

**USA**  
**Cleveland (industrial)**  
Tel: +1 216-896-3000  
Fax: +1 216-896-4031  
**Lincolnshire (mobile)**  
Tel: +1 847-821-1500  
Fax: +1 847-821-7600

**Parker Hannifin is the world's premier supplier of motion and control systems and solutions, with sales and manufacturing facilities throughout the world. For product information and details of your nearest Parker sales office, visit us at [www.parker.com/euro\\_mcd](http://www.parker.com/euro_mcd) or call free on 00800 2727 5374.**



Catalogue HY17-8200/UK  
PDF 03/04

© Copyright 2004  
Parker Hannifin Corporation  
All rights reserved.