

9 Displacements 9 Schluckvolumen 9 Cylindrée 9 Despazamientos	(3.6 – 24.1 in ³ /rev) 59...395 cm ³ /rev	
Maximum Pressure Eingangsdruck Pression entrée Presion Maxima	Cont (2500 psid) ...172.4 bar	Int (3000 psid) ...206.8 bar
Maximum Oil Flow Schluckstrom Débit d'huile Caudal Maximo de Aceite	(30 gpm) ...113.6 lpm	
Maximum Speed Drehzahl Vitesse de rotation Velocidad Maxima	858 rpm	
Maximum Torque Max Drehmoment Couple Torque Maximo	Cont (4164 lb in) ...470 Nm	Int (5215 lb in) ...589 Nm
Maximum Side Load at Key Seitenlast Charges latérales Carga Maxima Lateral	(1450 lb) ... 6450 N	

When the Ultimate in Efficiency and Reliability is a Must

This high performance motor contains a power element that is pressure loaded against internal leakage for high volumetric efficiency. It is wear compensated, so that its volumetric efficiency will not degrade with use. It can provide up to 5215 lb-in of torque through a one-piece solid fixed axis shaft. This shaft design allows for full stationary spline contact between shaft and rotor, minimizing spline contact stresses. It also allows the shaft to be extended through the rear cover for mounting parking brakes, auxiliary drive functions or encoders for speed readout or closed loop control. Low internal pressure drop means high mechanical efficiency and higher flow capability. This rugged motor is the most compact on the market.

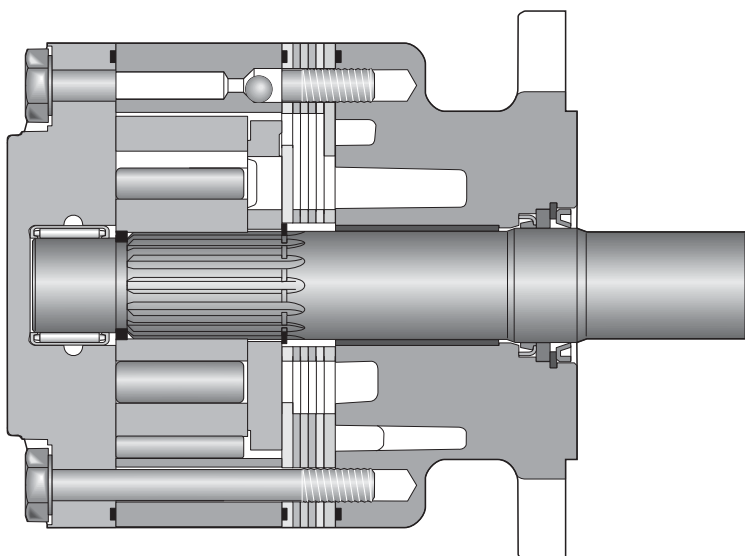

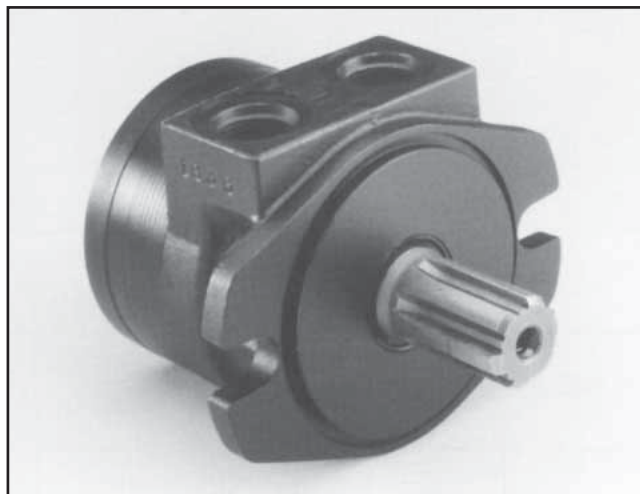
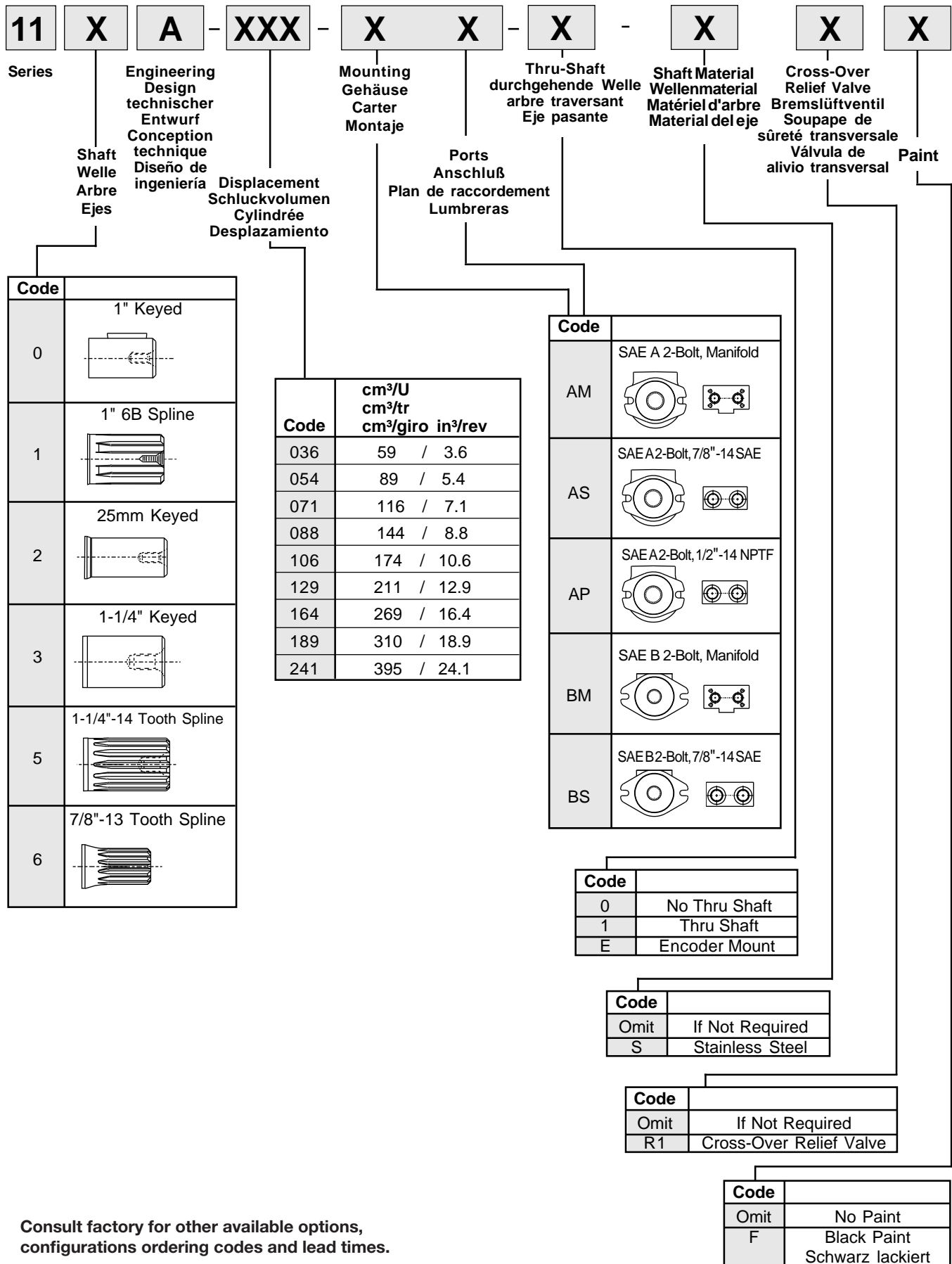

Consult factory for other available options, configurations ordering codes and lead times.

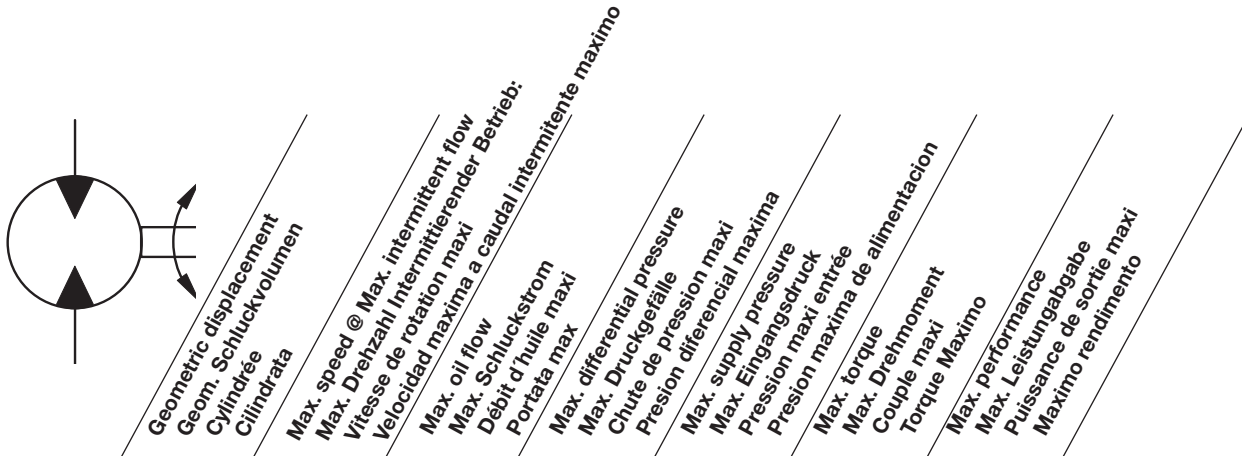

Motor Series 110A	cm ³ /rev in ³ /rev	rev/min	cont / int* l/min g/min		cont / int* bar psid		max bar psig	cont / int* Nm lb-in		max KW HP
110A 036	59 3.6	858	45.4 12	53 14	170 2500	210 3000	225 3250	127 1125	149 1319	8.5 11.4
110A 054	89 5.4	740	60.6 16	68.1 18	170 2500	210 3000	225 3250	182 1608	213 1884	11.2 15.1
110A 071	116 7.1	684	75.7 20	83.3 22	170 2500	210 3000	225 3250	256 2267	308 2725	14.2 19.1
110A 088	144 8.8	622	75.7 20	94.6 25	170 2500	210 3000	225 3250	324 2874	389 3449	14.6 19.6
110A 106	174 10.6	519	75.7 20	94.5 25	155 2250	210 3000	225 3250	352 3115	465 4121	13.1 17.6
110A 129	211 12.9	437	75.7 20	94.6 25	155 2250	190 2750	225 3250	412 3651	503 4453	12.9 17.3
110A 164	269 16.4	415	75.7 20	114 30	140 2000	170 2500	225 3250	470 4164	589 5215	12.1 16.2
110A 189	310 18.9	350	75.7 20	114 30	140 2000	170 2500	225 3250	542 4803	675 5977	7.9 10.6
110A 241	395 24.1	279	75.7 20	114 30	120 1750	155 2250	225 3250	594 5261	764 6765	9.2 12.4

Performance data based on tests using 15W40 oil with a viscosity of 55 cSt (215 SUS) at 54° C (130° F). Performance data is typical. Actual data may vary slightly from one production motor to another.

Les données sur les performances sont basées sur des tests utilisant de l'huile 15W40 d'une viscosité de 55 cSt (215 SUS) à 54°C (130°F). Ces données correspondent à des situations typiques. Les données réelles peuvent varier légèrement d'un moteur de production à l'autre.

Leistungsdaten sind gemessen mit SAE 15W40 bei einer Viskosität von 43,1 Cst bei 54°C. Geringfügige Abweichungen von den Katalogerten sind möglich.

Datos técnicos obtenidos con aceite 15W40 de 55 cSt (215 SUS) de viscosidad a 54°C (130°F). Los datos proporcionados son valores típicos. Los valores exactos reales podrían tener una pequeña variación entre distintos motores.

* Intermittent operation rating applies to 10% of every minute.
Intermittierende Werte maximal 10% von jeder Betriebsminute.
Fonctionnement interm. 10% max. de chaque minute d'utilisation.
Capacidad de funcionamiento intermitente valida para 10% por cada minuto.

110A 036

3.6 cu in / rev

PRESSURE (PSID)

	500	1000	1500	2000	2500	3000	3500
2	244	473	688	882	1031		
	128	124	119	105	82		
4	238	471	700	905	1067	1203	1293
	257	251	245	226	193	139	87
6	232	470	713	928	1103	1255	1344
	385	381	377	362	331	289	250
8	226	461	700	922	1117	1289	1404
	513	508	503	490	454	403	359
10	221	453	688	917	1132	1324	1464
	642	635	629	622	584	526	481
12	216	443	675	897	1117	1349	1564
	770	762	755	747	708	651	601
14	212	433	662	877	1103	1375	1664
	898	889	880	871	835	782	728

FLOW (GPM)

TORQUE (LB IN) 1664
SPEED (RPM) 728

59 cc / rev

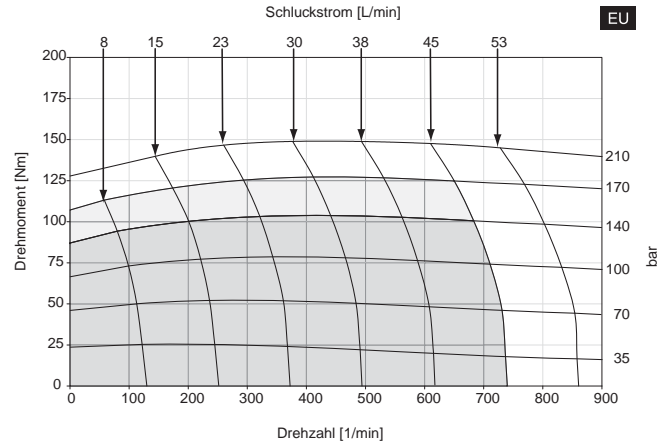

110A 054

5.4 cu in / rev

PRESSURE (PSID)

	500	1000	1500	2000	2500	3000	3500
2	365	716	1051	1368	1635		
	86	83	80	72	58		
4	365	713	1076	1407	1700	1957	2134
	171	167	164	153	134	101	60
6	361	722	1100	1445	1765	2055	2278
	257	253	250	244	226	198	171
8	352	713	1057	1419	1731	2020	2237
	342	338	334	329	309	278	247
10	340	713	1057	1392	1697	1985	2196
	428	424	419	415	396	366	332
12	331	679	1038	1382	1697	2011	2316
	513	508	503	498	480	450	408
14	318	653	1019	1372	1732	2129	2543
	599	593	587	581	566	536	488
16	309	636	987	1335	1700	2091	2491
	684	678	671	664	645	618	566
18	281	600	955	1298	1668	2052	2438
	770	762	755	747	724	701	647
20	264	567	880	1220	1581	1947	2235
	856	849	843	830	804	785	729
22	247	541	824	1190	1593	2026	2423
	942	936	931	913	885	871	813

FLOW (GPM)

TORQUE (LB IN) 2491
SPEED (RPM) 566

89 cc / rev

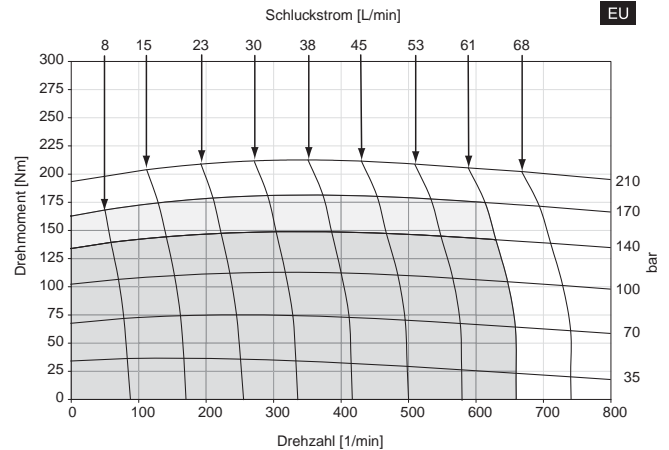

■ Cont. ■ Cont. with no side load □ Int.
 ■ Int. with rated side load

Intermittent operation rating applies to 10% of every minute.
Fonctionnement interm. 10% max. de chaque minute d'utilisation.

Performance data based on tests using 15W40 oil with a viscosity of 55 cSt (215 SUS) at 54°C (130°F). Performance data is typical. Actual data may vary slightly from one production motor to another.

Les données sur les performances sont basées sur des tests utilisant de l'huile 15W40 d'une viscosité de 55 cSt (215 SUS) à 54°C (130°F). Ces données correspondent à des situations typiques. Les données réelles peuvent varier légèrement d'un moteur de production à l'autre.

020 110A.indd, js

Intermittierende Werte maximal 10% von jeder Betriebsminute.

Capacidad de funcionamiento intermitente valida para 10% por cada minuto.

Leistungsdaten sind gemessen mit SAE 15W40 bei einer Viskosität von 43,1 Cst bei 54°C. Geringfügige Abweichungen von den Katalogerten sind möglich.

Datos técnicos obtenidos con aceite 15W40 de 55 cSt (215 SUS) de viscosidad a 54°C (130°F). Los datos proporcionados son valores típicos. Los valores exactos reales podrían tener una pequeña variación entre distintos motores.

110A 071

7.1 cu in / rev

PRESSURE (PSID)

	500	1000	1500	2000	2500	3000	3500
2	480 65	949 63	1407 62	1853 56	2260 47		
4	480 130	994 128	1492 125	1989 118	2430 105	2848 83	3243 47
6	458 195	972 192	1483 189	1966 187	2458 176	2915 154	3322 133
8	446 260	961 258	1475 255	1966 251	2458 239	2915 219	3362 193
10	424 325	927 322	1449 319	1944 316	2444 306	2915 290	3382 260
12	412 390	904 387	1407 383	1921 379	2444 371	2898 353	3391 316
14	396 455	859 451	1373 447	1876 442	2373 437	2882 419	3401 374
16	379 521	825 515	1339 510	1853 505	2345 497	2848 482	3342 429
18	362 586	791 580	1288 574	1785 568	2317 556	2814 545	3283 486
20	339 651	757 644	1237 638	1763 631	2288 618	2780 608	3243 543
22	305 716	701 709	1187 701	1740 694	2232 680	2746 673	3243 601

FLOW (GPM)

TORQUE (LB IN) 701
SPEED (RPM) 709

116 cc / rev

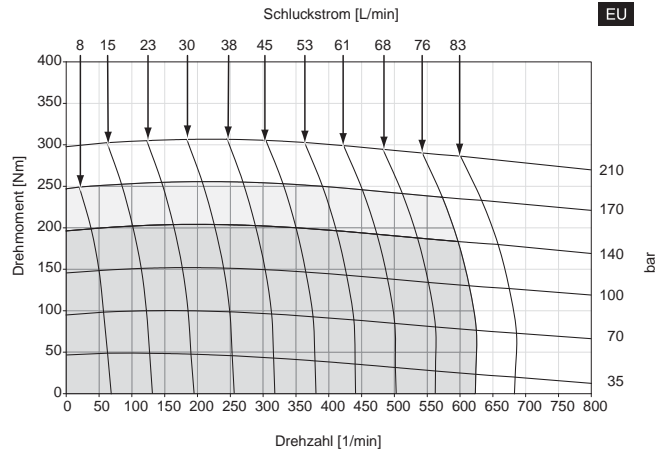

Intermittent operation rating applies to 10% of every minute.
Fonctionnement interm. 10% max. de chaque minute d'utilisation.

Performance data based on tests using 15W40 oil with a viscosity of 55 cSt (215 SUS) at 54° C (130° F). Performance data is typical. Actual data may vary slightly from one production motor to another.

Les donnees sur les performances sont basees sur des tests utilisant de l'huile 15W40 d'une viscosite de 55 cSt (215 SUS) a 54°C (130°F). Ces donnees correspondent a des situations typiques. Les donnees reelles peuvent varier legerement d'un moteur de production a l'autre.

020 110A.indd, js

■ Cont. □ Cont. with no side load □ Int.
 □ Int. with rated side load

Intermittierende Werte maximal 10% von jeder Betriebsminute.

Capacidad de funcionamiento intermitente valida para 10% por cada minuto.

Leistungsdaten sind gemessen mit SAE 15W40 bei einer Viskosität von 43,1 Cst bei 54°C. Geringfügige Abweichungen von den Katalogerten sind möglich.

Datos tecnicos obtenidos con aceite 15W40 de 55 cSt (215 SUS) de viscosidad a 54°C (130°F). Los datos proporcionados son valores tipicos. Los valores exactos reales podrian tener una pequena variacion entre distintos motores.

110A 088

8.8 cu in / rev

PRESSURE (PSID)

	500	1000	1500	2000	2500	3000	3500
2	605 52	1210 51	1774 50	2324 48	2869 41		
4	590 105	1207 103	1804 102	2387 99	2975 88	3475 73	3929 63
6	574 158	1204 156	1833 154	2451 152	3080 142	3593 126	4141 107
8	553 210	1183 208	1817 206	2437 203	3067 192	3634 178	4154 159
10	532 263	1162 261	1801 259	2423 253	3054 243	3675 235	4167 219
12	509 315	1127 312	1762 309	2381 303	3006 295	3623 284	4179 264
14	487 367	1092 363	1722 358	2339 353	2958 347	3571 335	4192 310
16	468 420	1044 415	1659 411	2269 403	2914 396	3529 384	4143 362
18	448 472	997 468	1595 463	2199 454	2870 444	3487 435	4094 416
20	428 525	973 520	1551 516	2178 507	2832 499	3446 486	4051 458
22	408 578	949 573	1506 569	2158 562	2794 555	3405 537	4008 499
25	348 656	846 651	1423 647	2008 636	2610 625	3191 608	3809 575
30	279 787	740 782	1313 776	1821 760	2381 744	2921 725	3555 697

FLOW (GPM)

144 cc / rev

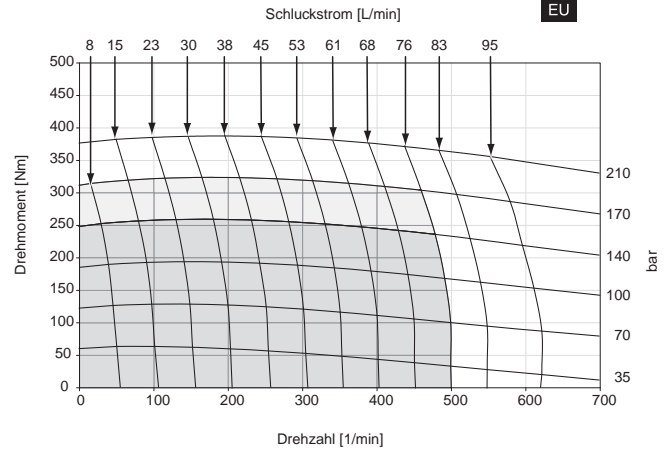

Intermittent operation rating applies to 10% of every minute.
Fonctionnement interm. 10% max. de chaque minute d'utilisation.

Performance data based on tests using 15W40 oil with a viscosity of 55 cSt (215 SUS) at 54° C (130° F). Performance data is typical. Actual data may vary slightly from one production motor to another.

Les données sur les performances sont basées sur des tests utilisant de l'huile 15W40 d'une viscosité de 55 cSt (215 SUS) à 54°C (130°F). Ces données correspondent à des situations typiques. Les données réelles peuvent varier légèrement d'un moteur de production à l'autre.

020.110A.indd.js

Intermittierende Werte maximal 10% von jeder Betriebsminute.

Capacidad de funcionamiento intermitente valida para 10% por cada minuto.

Leistungsdaten sind gemessen mit SAE 15W40 bei einer Viskosität von 43,1 Cst bei 54°C. Geringfügige Abweichungen von den Katalogerten sind möglich.

Datos técnicos obtenidos con aceite 15W40 de 55 cSt (215 SUS) de viscosidad a 54°C (130°F). Los datos proporcionados son valores típicos. Los valores exactos reales podrían tener una pequeña variación entre distintos motores.

- Cont.
- Cont. with no side load
- Int. with rated side load
- Int.

110A 106

10.6 cu in / rev

PRESSURE (PSID)

	500	1000	1500	1750	2000	2250	2500	2750	3000	3250	3500
2	742 44	1501 43	2227 42	2569 41	2919 40	3264 39	3585 37	3897 34	4201 31	4537 27	4871 23
4	721 87	1485 86	2214 85	2576 83	2935 82	3302 79	3669 76	3990 71	4251 66	4599 61	4945 57
6	700 131	1468 129	2202 128	2583 127	2969 126	3359 122	3754 118	4036 112	4302 106	4660 104	5019 102
8	675 174	1442 173	2189 171	2569 169	2952 166	3340 162	3733 158	4071 153	4403 149	4715 146	5019 144
10	650 218	1417 216	2176 214	2554 210	2935 207	3321 203	3711 198	4106 197	4504 196	4770 193	5019 190
12	616 262	1383 258	2138 255	2509 252	2885 248	3264 245	3648 241	4025 238	4403 235	4715 232	5019 229
14	582 305	1350 301	2100 296	2465 293	2834 290	3207 287	3585 284	3943 279	4302 275	4660 272	5019 268
16	567 349	1278 344	2050 340	2410 336	2775 331	3155 328	3543 324	3903 320	4264 316	4626 311	4989 307
18	553 392	1206 388	1999 384	2354 379	2716 373	3103 369	3501 365	3862 361	4226 357	4592 351	4960 345
20	529 436	1168 431	1885 427	2270 422	2674 416	3060 412	3458 408	3822 403	4188 399		
22	506 479	1130 475	1771 470	2185 465	2632 460	3018 455	3416 451	3781 446	4150 441		
25	492 545	1110 541	1747 537	2145 531	2573 526	2951 520	3342 515	3700 511	4061 507		
30	470 654	1076 651	1708 647	2078 641	2474 634	2840 628	3219 621	3564 615	3913 608		

TORQUE (LB IN) 5019
SPEED (RPM) 229

FLOW (GPM)

174 cc / rev

Schluckstrom [L/min]

EU

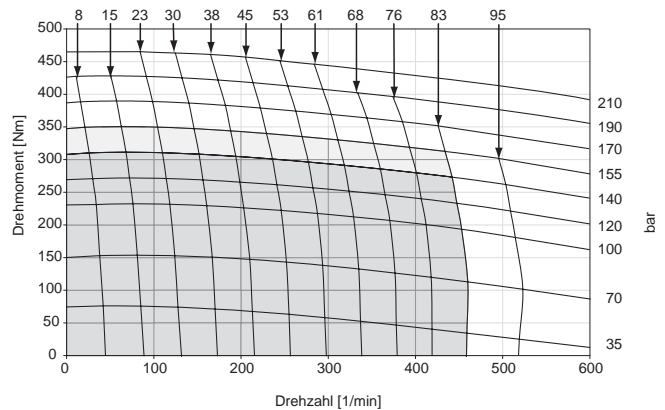

■ Cont. ■ Cont. with no side load □ Int. with rated side load

Intermittent operation rating applies to 10% of every minute.
Fonctionnement interm. 10% max. de chaque minute d'utilisation.

Performance data based on tests using 15W40 oil with a viscosity of 55 cSt (215 SUS) at 54° C (130° F). Performance data is typical. Actual data may vary slightly from one production motor to another.

Les données sur les performances sont basées sur des tests utilisant de l'huile 15W40 d'une viscosité de 55 cSt (215 SUS) à 54°C (130°F). Ces données correspondent à des situations typiques. Les données réelles peuvent varier légèrement d'un moteur de production à l'autre.

020 110A.indd, js

Intermittierende Werte maximal 10% von jeder Betriebsminute.

Capacidad de funcionamiento intermitente valida para 10% por cada minuto.

Leistungsdaten sind gemessen mit SAE 15W40 bei einer Viskosität von 43,1 Cst bei 54°C. Geringfügige Abweichungen von den Katalogerten sind möglich.

Datos técnicos obtenidos con aceite 15W40 de 55 cSt (215 SUS) de viscosidad a 54°C (130°F). Los datos proporcionados son valores típicos. Los valores exactos reales podrían tener una pequeña variación entre distintos motores.

110A 129

12.9 cu in / rev

PRESSURE (PSID)

	500	1000	1500	1750	2000	2250	2500	2750	3000	3250	3500
2	905	1827	2698	3112	3527	3943	4336	4729	5115	5522	5925
	36	35	34	33	32	31	29	27	25	23	20
4	880	1807	2691	3128	3567	3999	4420	4805	5180	5599	6017
	72	70	69	68	66	64	62	58	55	51	48
6	854	1786	2684	3144	3607	4055	4503	4881	5245	5677	6108
	107	106	105	104	103	100	97	93	89	87	85
8	822	1755	2666	3122	3582	4035	4490	4912	5330	5723	6108
	143	142	140	139	137	134	130	127	123	121	118
10	790	1725	2648	3101	3556	4015	4476	4944	5416	5769	6108
	179	177	175	173	171	168	164	162	160	157	154
12	750	1683	2605	3060	3511	3965	4419	4867	5324	5718	6104
	215	212	210	208	205	202	199	196	193	189	186
14	710	1642	2562	3020	3465	3914	4363	4790	5233		
	251	247	244	242	240	237	234	230	226		
16	685	1557	2501	2948	3394	3850	4309	4742	5183		
	287	283	280	277	274	271	268	263	259		
18	661	1472	2439	2876	3322	3785	4256	4695	5133		
	322	319	316	312	307	304	301	297	293		
20	628	1418	2294	2741	3205	3651	4105	4522			
	358	355	351	347	343	339	336	331			
22	596	1363	2150	2605	3089	3517	3954				
	394	390	386	382	378	374	370				
25	571	1322	2093	2532	2997	3427	3869				
	448	444	440	436	431	427	422				
30	531	1254	1999	2410	2843	3276					
	537	533	530	524	519	514					

TORQUE (LB IN) 6108
SPEED (RPM) 154

FLOW (GPM)

211 cc / rev

Schluckstrom [L/min]

EU

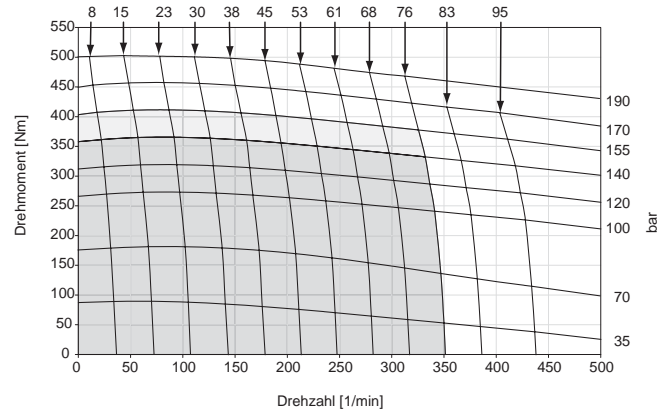

■ Cont. ■ Cont. with no side load □ Int.
 ■ Int. with rated side load

Intermittent operation rating applies to 10% of every minute.
Fonctionnement interm. 10% max. de chaque minute d'utilisation.

Performance data based on tests using 15W40 oil with a viscosity of 55 cSt (215 SUS) at 54°C (130°F). Performance data is typical. Actual data may vary slightly from one production motor to another.

Les données sur les performances sont basées sur des tests utilisant de l'huile 15W40 d'une viscosité de 55 cSt (215 SUS) à 54°C (130°F). Ces données correspondent à des situations typiques. Les données réelles peuvent varier légèrement d'un moteur de production à l'autre.

020 110A.indd.js

Intermittierende Werte maximal 10% von jeder Betriebsminute.

Capacidad de funcionamiento intermitente valida para 10% por cada minuto.

Leistungsdaten sind gemessen mit SAE 15W40 bei einer Viskosität von 43,1 Cst bei 54°C. Geringfügige Abweichungen von den Katalogerten sind möglich.

Datos tecnicos obtenidos con aceite 15W40 de 55 cSt (215 SUS) de viscosidad a 54°C (130°F). Los datos proporcionados son valores tipicos. Los valores exactos reales podrian tener una pequena variacion entre distintos motores.

110A 164

16.4 cu in / rev

PRESSURE (PSID)

	500	1000	1500	1750	2000	2250	2500	2750	3000	3250
2	1155 28	2323 27	3406 26	3928 25	4437 24	4954 23	5462 22	5986 21	6507 20	7020 19
4	1122 56	2297 55	3414 54	3963 53	4505 51	5023 49	5530 48	6065 46	6597 44	7124 43
6	1088 85	2271 84	3422 83	3997 82	4573 80	5092 79	5599 77	6144 74	6687 72	7227 70
8	1047 113	2232 112	3394 110	3963 109	4531 108	5071 106	5605 104	6164 101	6722 98	7247 95
10	1005 141	2193 139	3367 138	3928 137	4489 135	5051 133	5612 131	6184 128	6758 125	
12	955 169	2061 167	3318 166	3888 164	4463 163	5021 161	5579 158	6141 155		
14	904 197	2086 195	3269 193	3878 192	4437 191	4998 188	5547 185	6072 181		
16	861 225	1925 223	3191 221	3763 219	4346 217	4908 215	5475 212			
18	818 254	1879 251	3113 248	3677 246	4255 243	4827 241				
20	783 282	1853 279	3015 276	3577 273	4155 270	4733 268				
22	718 310	1710 307	2721 304	3209 301	3706 297	4170 294				
25	672 352	1626 349	2596 345	3068 342	3550 338	4038 335				
30	596 423	1488 418	2388 414	2832 410	3289 406	3817 401				

TORQUE (LB IN) 6758
SPEED (RPM) 125

FLOW (GPM)

269 cc / rev

Schluckstrom [L/min]

EU

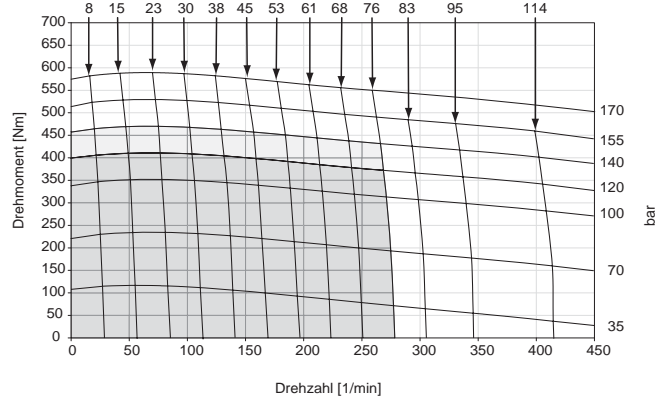

■ Cont. ■ Cont. with no side load □ Int.
 ■ Int. with rated side load

Intermittent operation rating applies to 10% of every minute.
Fonctionnement interm. 10% max. de chaque minute d'utilisation.

Performance data based on tests using 15W40 oil with a viscosity of 55 cSt (215 SUS) at 54° C (130° F). Performance data is typical. Actual data may vary slightly from one production motor to another.

Les données sur les performances sont basées sur des tests utilisant de l'huile 15W40 d'une viscosité de 55 cSt (215 SUS) à 54°C (130°F). Ces données correspondent à des situations typiques. Les données réelles peuvent varier légèrement d'un moteur de production à l'autre.

020 110A.indd, js

Intermittierende Werte maximal 10% von jeder Betriebsminute.

Capacidad de funcionamiento intermitente valida para 10% por cada minuto.

Leistungsdaten sind gemessen mit SAE 15W40 bei einer Viskosität von 43,1 Cst bei 54°C. Geringfügige Abweichungen von den Katalogerten sind möglich.

Datos técnicos obtenidos con aceite 15W40 de 55 cSt (215 SUS) de viscosidad a 54°C (130°F). Los datos proporcionados son valores típicos. Los valores exactos reales podrían tener una pequeña variación entre distintos motores.

110A 189

18.9 cu in / rev

PRESSURE (PSID)

	500	1000	1250	1500	1750	2250	2500
2	1285 23	2619 22	3224 21	3838 20	4442 18	5548 16	6131 13
4	1264 47	2589 46	3250 45	3859 44	4486 42	5668 40	6282 38
6	1228 73	2559 72	3240 71	3865 70	4513 69	5765 67	6409 66
8	1171 97	2509 96	3176 95	3829 94	4503 93	5771 90	6439 89
10	1114 121	2449 120	3111 119	3793 118	4476 117	5777 114	6468 112
12	1065 145	2391 144	3061 143	3750 142	4439 141	5747 137	
14	1016 169	2333 168	3011 167	3707 166	4402 165	5717 161	
16	975 200	2257 199	2938 198	3636 197	4326 195	5645 185	
18	966 232	1988 230	2506 228	3037 227	3563 226		
20	941 263	1815 261	2253 259	2702 258	3143 256		
22	916 295	1643 293	2001 290	2367 288	2724 286		
25	879 342	1384 339	1622 335	1865 334	2094 331		
30	816 420	952 417	990 412	1027 410	1045 407		

FLOW (GPM)

310 cc / rev

Schluckstrom [L/min]

EU

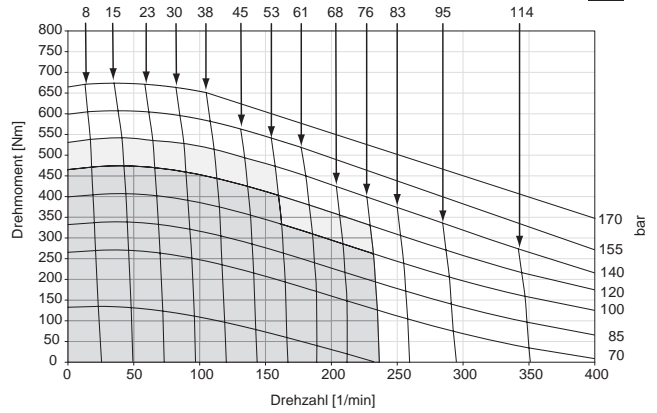

TORQUE (LB IN) 2724
SPEED (RPM) 286

Intermittent operation rating applies to 10% of every minute.
Fonctionnement interm. 10% max. de chaque minute d'utilisation.

Performance data based on tests using 15W40 oil with a viscosity of 55 cSt (215 SUS) at 54° C (130° F). Performance data is typical. Actual data may vary slightly from one production motor to another.

Les données sur les performances sont basées sur des tests utilisant de l'huile 15W40 d'une viscosité de 55 cSt (215 SUS) à 54°C (130°F). Ces données correspondent à des situations typiques. Les données réelles peuvent varier légèrement d'un moteur de production à l'autre.

020.110A.indd.js

■ Cont. ■ Cont. with no side load □ Int.
 Int. with rated side load

Intermittierende Werte maximal 10% von jeder Betriebsminute.

Capacidad de funcionamiento intermitente valida para 10% por cada minuto.

Leistungsdaten sind gemessen mit SAE 15W40 bei einer Viskosität von 43,1 Cst bei 54°C. Geringfügige Abweichungen von den Katalogerten sind möglich.

Datos tecnicos obtenidos con aceite 15W40 de 55 cSt (215 SUS) de viscosidad a 54°C (130°F). Los datos proporcionados son valores tipicos. Los valores exactos reales podrian tener una pequena variacion entre distintos motores.

110A 241

24.1 cu in / rev

PRESSURE (PSID)

	500	1000	1250	1500	1750	2250
2	1515 15	3184 14	3884 12	4660 11	5427 10	6645 9
4	1534 35	3145 34	4027 32	4718 30	5504 29	6904 28
6	1496 56	3107 55	4027 54	4718 53	5504 52	7077 51
8	1400 74	3030 73	3884 72	4660 70	5571 68	7163 66
10	1304 93	2915 92	3740 91	4603 90	5571 89	
12	1266 112	2851 112	3708 110	4584 109	5549 107	
14	1227 130	2787 129	3676 128	4564 127	5527 126	
16	1189 149	2723 148	3644 147	4545 146	5504 144	
18	1170 167	2685 166	3596 165	4488 164	5437 162	
20	1151 184	2685 183	3596 182	4430 180	5370 178	
22	1112 205	2608 204	3452 203	4258 202	5169 200	
25	1055 235	2455 232	3260 231	4085 230	4900 228	
30	959 288	2225 285	2925 282	3682 279	4363 273	

FLOW (GPM)

TORQUE (LB IN) 5169
SPEED (RPM) 200

395 cc / rev

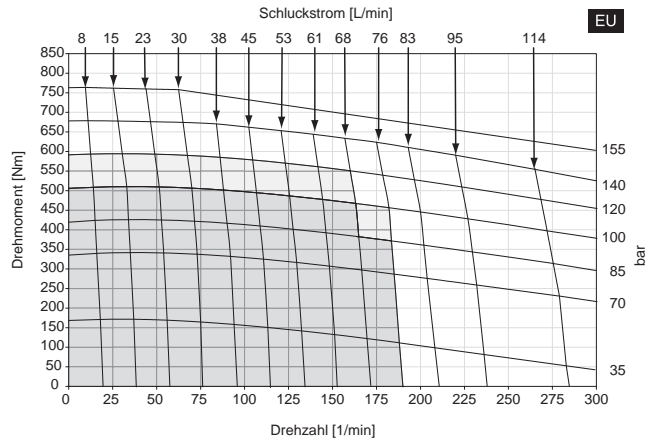

EU

Cont.
 Cont. with no side load
 Int. with rated side load
 Int.

Intermittent operation rating applies to 10% of every minute.
Fonctionnement interm. 10% max. de chaque minute d'utilisation.

Performance data based on tests using 15W40 oil with a viscosity of 55 cSt (215 SUS) at 54°C (130°F). Performance data is typical. Actual data may vary slightly from one production motor to another.

Les données sur les performances sont basées sur des tests utilisant de l'huile 15W40 d'une viscosité de 55 cSt (215 SUS) à 54°C (130°F). Ces données correspondent à des situations typiques. Les données réelles peuvent varier légèrement d'un moteur de production à l'autre.

020 110A.indd, js

Intermittierende Werte maximal 10% von jeder Betriebsminute.

Capacidad de funcionamiento intermitente valida para 10% por cada minuto.

Leistungsdaten sind gemessen mit SAE 15W40 bei einer Viskosität von 43,1 Cst bei 54°C. Geringfügige Abweichungen von den Katalogerten sind möglich.

Datos técnicos obtenidos con aceite 15W40 de 55 cSt (215 SUS) de viscosidad a 54°C (130°F). Los datos proporcionados son valores típicos. Los valores exactos reales podrían tener una pequeña variación entre distintos motores.

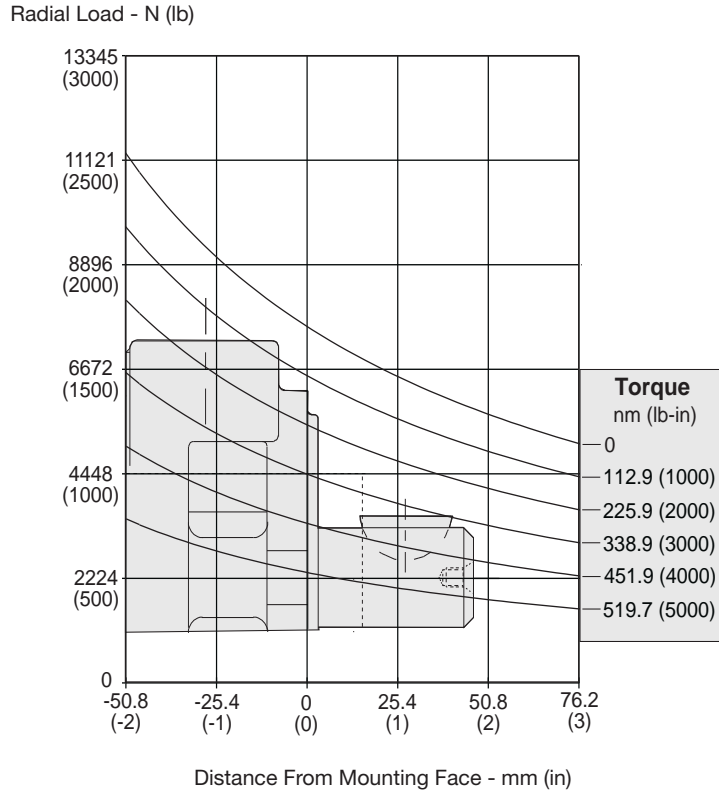

The allowable side load curve is based on L_{10} bushing life of 3×10^6 revolutions @ 100 RPM.
 Die zulässige radiale Wellenbelastung bezieht sich auf die Lager-Lebensdauer 3×10^6 Umdrehungen.
 L'effort radial admissible sur l'arbre depend a une duree de vie 3×10^6 de rotation.
 La curva de carga lateral admisible se basa en vida util de cojinete de 3×10^6 revoluciones.

Equation to Calculate the Expected Radial Bearing Life
Gleichung zur Ermittlung der Lagerlebensdauer

Equation to calculate the dynamic bearing life for a given load:
 Bestimmung der erlaubten radialen Wellenbelastung mit vorgegebener Last

Use F_a , F_b and S in equation to determine hours of L_{10} bearing life.
 Die Lebensdauer in Stunden ergibt sich durch einsetzen von F_a , F_b , und S in die nachstehende Formel.

$$L = \frac{3.0 \times 10^6}{60 \times S} \left\{ \frac{F_a}{F_b} \right\}^{3.33}$$

Where / Mit:

- S = Shaft Speed RPM / Abtriebswellendrehzahl in min^{-1}
- L = Life In Hours / Lebensdauer in Stunden
- F_a = Allowable side load defined by above curve at a distance from mounting flange. / Erlaubte radiale Wellenbelastung als Function der Laenge
- F_b = Application side load. / Anwendungsseitige Wellenbelastung

Note: Calculations are based on L_{10} bearing life per ISO 281.
 Auslegung basiert auf einer L_{10} Lebensdauer nach ISO 281

Code: AM

**SAE A 2-Bolt,
Manifold**

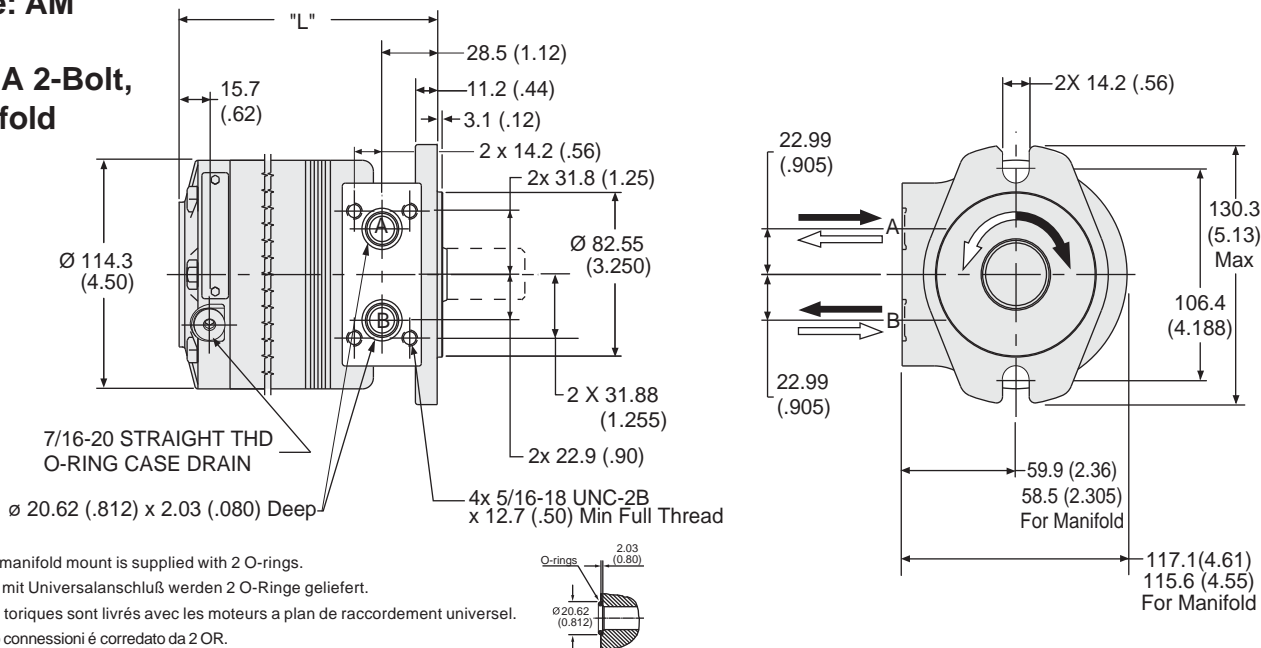

Code AM	036	054	071	088	106	129	164	189	241
Weight/Gewicht	7.0	7.4	7.7	8.0	8.4	8.7	9.4	9.8	10.8
Poids/Peso	(15.4)	(16.2)	(16.9)	(17.5)	(18.4)	(19.1)	(20.6)	(21.6)	(23.7)
Length	"L" mm	112	117	121	127	131	147	154	169
	"L" (in)	(4.41)	(4.60)	(4.78)	(4.98)	(5.17)	(5.80)	(6.07)	(6.64)

Code: AS

**SAE A 2-Bolt,
7/8"-14 SAE
O-Ring**

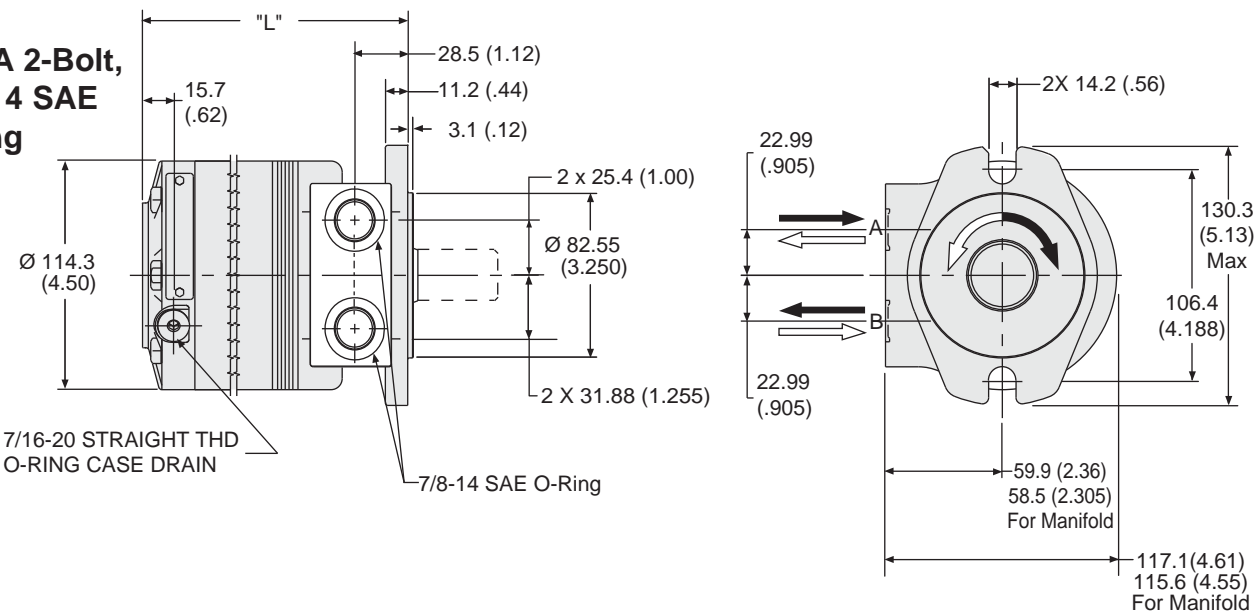

Code AS	036	054	071	088	106	129	164	189	241
Weight/Gewicht	7.0	7.4	7.7	8.0	8.4	8.7	9.4	9.8	10.8
Poids/Peso	(15.4)	(16.2)	(16.9)	(17.5)	(18.4)	(19.1)	(20.6)	(21.6)	(23.7)
Length	"L" mm	112	117	121	127	131	147	154	169
	"L" (in)	(4.41)	(4.60)	(4.78)	(4.98)	(5.17)	(5.80)	(6.07)	(6.64)

English equivalents for metric specifications are shown in ().

020 110A.indd, js

Code: AP

**SAE A 2-Bolt,
1/2" BSPP**

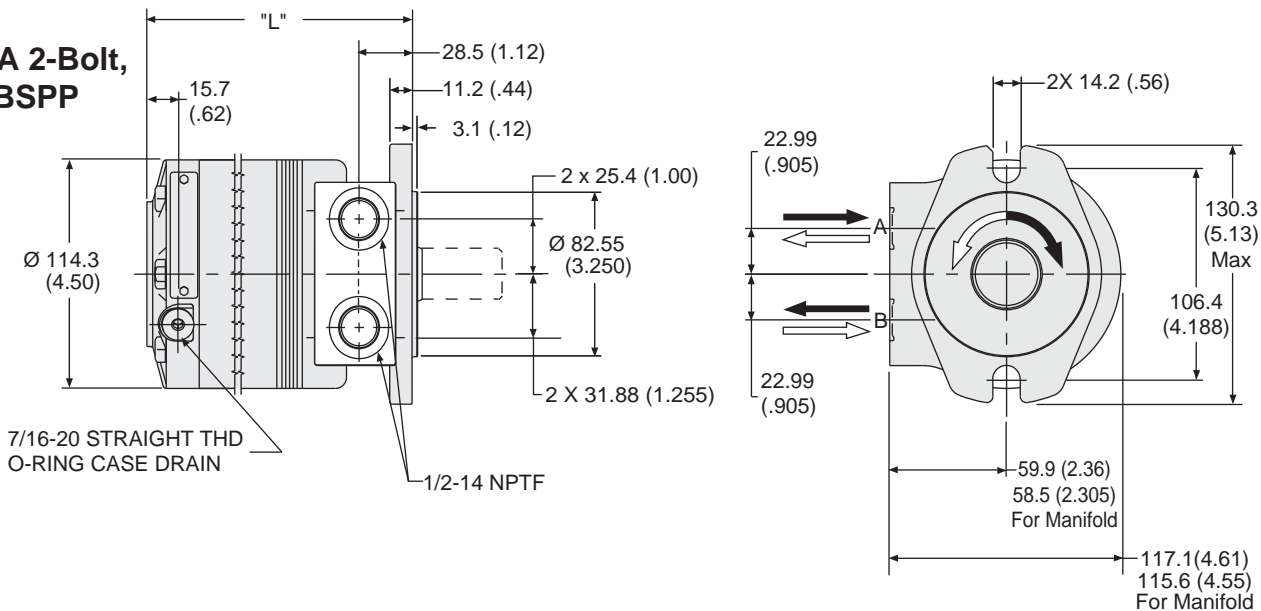

Code AT	036	054	071	088	106	129	164	189	241	
Weight/Gewicht	kg	7.0	7.4	7.7	8.0	8.4	8.7	9.4	9.8	10.8
Poids/Peso	(lb)	(15.4)	(16.2)	(16.9)	(17.5)	(18.4)	(19.1)	(20.6)	(21.6)	(23.7)
Length	"L" mm	112	117	121	127	131	138	147	154	169
	"L" (in)	(4.41)	(4.60)	(4.78)	(4.98)	(5.17)	(5.42)	(5.80)	(6.07)	(6.64)

Code: BM

**SAE B 2-Bolt,
Manifold**

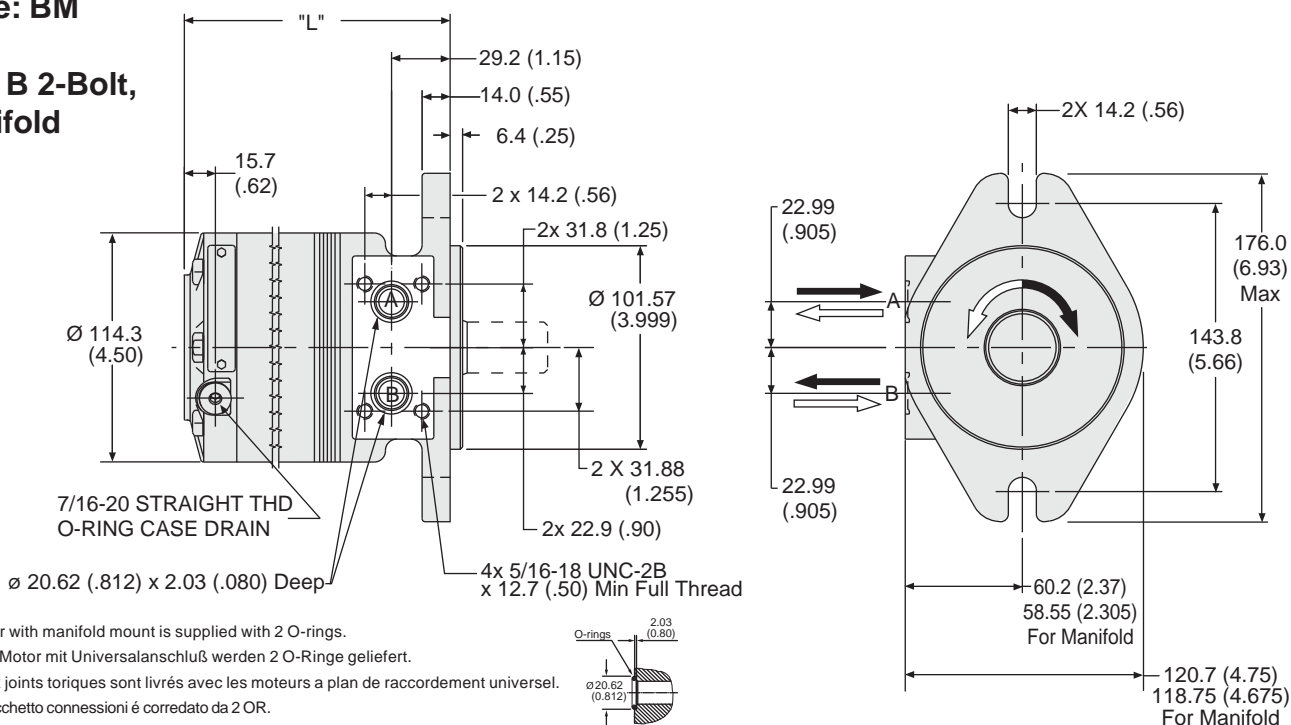

Motor with manifold mount is supplied with 2 O-rings.
 Zum Motor mit Universalanschluß werden 2 O-Ringe geliefert.
 Deux joints toriques sont livrés avec les moteurs a plan de raccordement universel.
 Il blocchetto connessioni é corredato da 2 OR.

Code BM	036	054	071	088	106	129	164	189	241	
Weight/Gewicht	kg	7.0	7.4	7.7	8.0	8.4	8.7	9.4	9.8	10.8
Poids/Peso	(lb)	(15.4)	(16.2)	(16.9)	(17.5)	(18.4)	(19.1)	(20.6)	(21.6)	(23.7)
Length	"L" mm	112	117	121	127	131	138	147	154	169
	"L" (in)	(4.41)	(4.60)	(4.78)	(4.98)	(5.17)	(5.42)	(5.80)	(6.07)	(6.64)

English equivalents for metric specifications are shown in ().

Code: BS

**SAE B 2-Bolt,
 7/8"-14 SAE
 O-Ring**

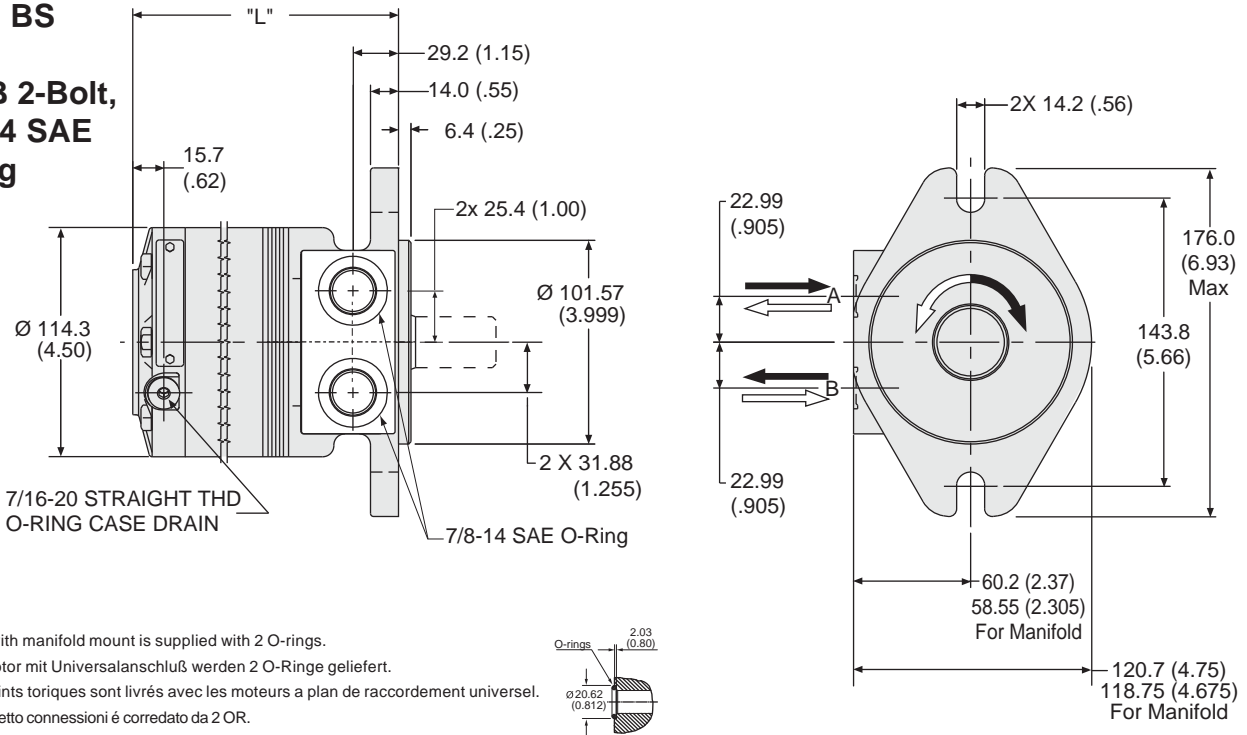

Motor with manifold mount is supplied with 2 O-rings.
 Zum Motor mit Universalanschluß werden 2 O-Ringe geliefert.
 Deux joints toriques sont livrés avec les moteurs a plan de raccordement universel.
 Il blocchetto connessione è corredato da 2 OR.

Code BS	036	054	071	088	106	129	164	189	241
Weight/Gewicht kg	7.0	7.4	7.7	8.0	8.4	8.7	9.4	9.8	10.8
Poids/Peso (lb)	(15.4)	(16.2)	(16.9)	(17.5)	(18.4)	(19.1)	(20.6)	(21.6)	(23.7)
Length "L" mm	112	117	121	127	131	138	147	154	169
"L" (in)	(4.41)	(4.60)	(4.78)	(4.98)	(5.17)	(5.42)	(5.80)	(6.07)	(6.64)

English equivalents for metric specifications are shown in ().

020 110A.indd, js

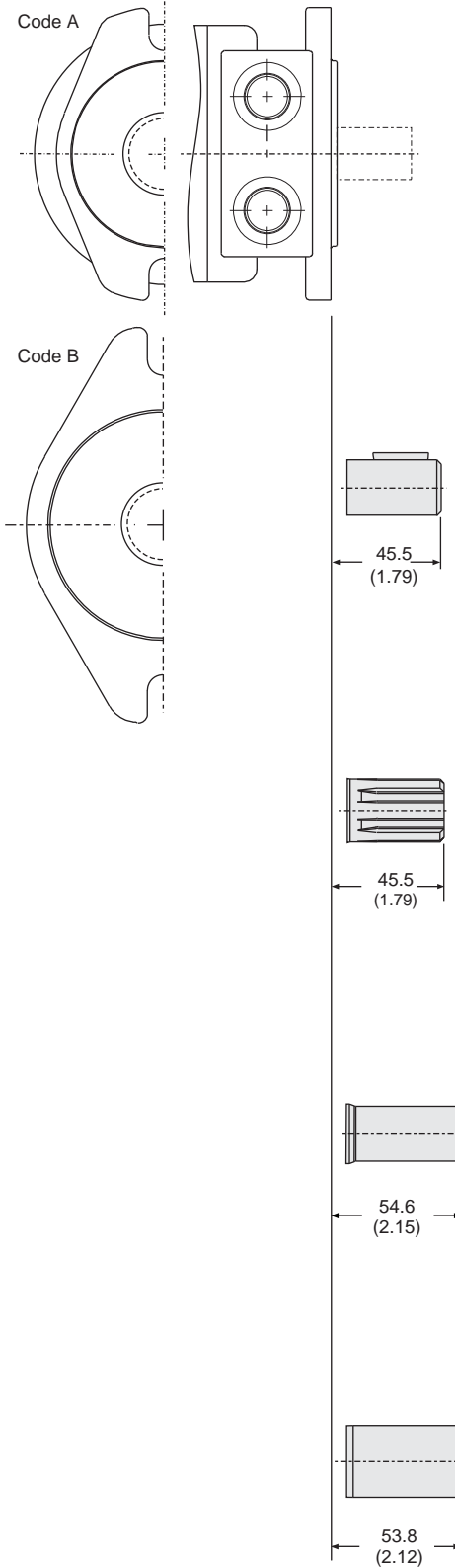

English equivalents for metric specifications are shown in ().

020 110A.indd, js

Code: 0

1" Keyed

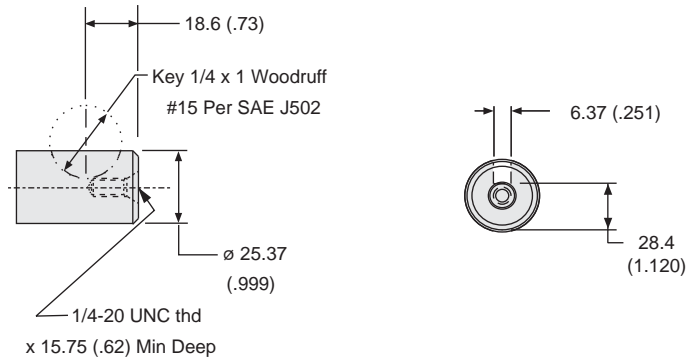

Code: 1

1" 6B Spline

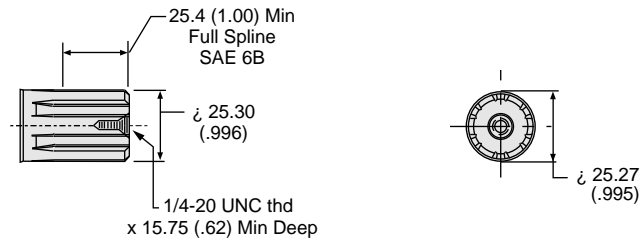

Code: 2

25mm Keyed

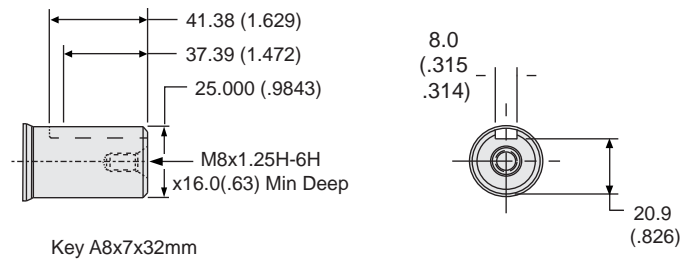

Code: 3

1-1/4" Keyed

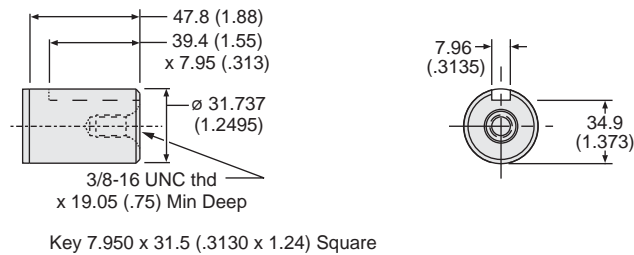

English equivalents for metric specifications are shown in ().

020 110A.indd, js

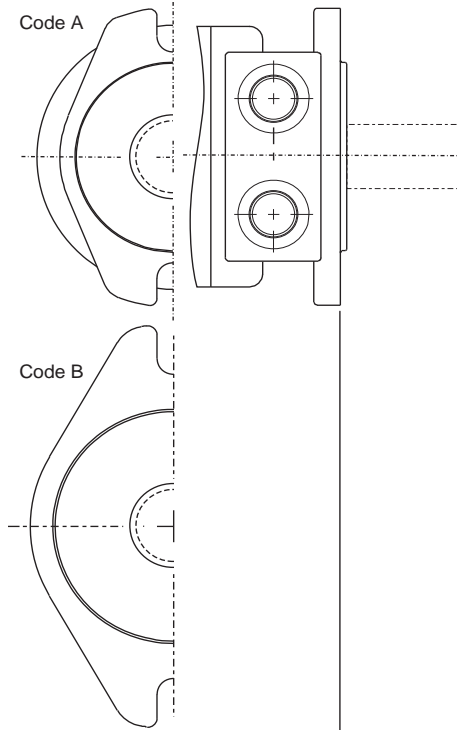

Code: 5

1-1/4"-14 Tooth Spline

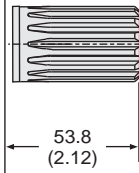

Code: 6

7/8"-13 Tooth Spline

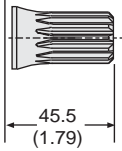

English equivalents for metric specifications are shown in ().

Code: 5

1-1/4"-14 Tooth Spline

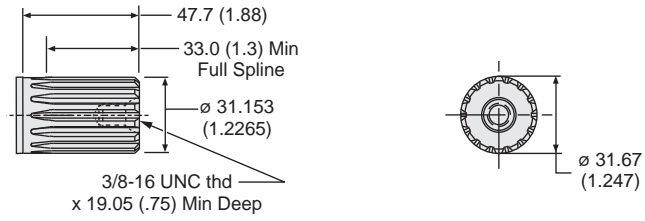

Code: 6

7/8"-13 Tooth Spline

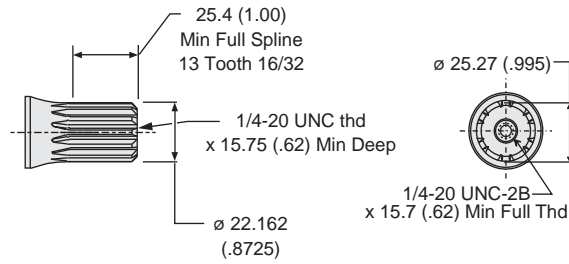

English equivalents for metric specifications are shown in ().

