



# **Hydraulic Motor/Pump Series F11/F12**

*Fixed Displacement*

*Catalogue HY17-8249/US  
March 2004*



<b>Conversion</b>	<b>factors</b>
1 kg .....	2.20 lb
1 N .....	0.225 lbf
1 Nm .....	0.738 lbf ft
1 bar .....	14.5 psi
1 l .....	0.264 US gallon
1 cm <sup>3</sup> .....	0.061 cu in
1 mm .....	0.039 in
$\frac{9}{5}^{\circ}\text{C} + 32$ .....	1 <sup>o</sup> F

<b>Content</b>	<b>Page</b>
General information .....	4
F11 cross section .....	4
F12 cross sections .....	5
Specifications .....	6
Ordering codes	
F11-CETOP .....	7
F11-ISO .....	8
F11-SAE .....	9
F12-ISO .....	10
F12-Cartridge .....	11
F12-SAE .....	12
Preferred versions F11/F12 .....	13
Technical information	
Bearing life .....	14
Bearing life calculation .....	14
Required information .....	14
Noise level .....	15
Efficiency .....	15
Selfpriming speed and required inlet pressure .....	16
Installation dimensions	
F11-5 CETOP .....	17
F11-10 CETOP .....	18
F11-14 CETOP .....	19
F11-19 CETOP .....	20
F11-14 ISO .....	21
F11-14 SAE .....	22
F11-19 SAE .....	23
F12-30, -40, -60, -80 and -110 ISO .....	24-25
F12-30, -40, -60, -80 and -110 Cartridge .....	26-27
F12-30, -40, -60, -80 and -110 4 bolt flange .....	28-29
F12-30, -40, and -60 2 bolt flange .....	30-31
F11-150 CETOP .....	32
F11-150 SAE .....	33
F11-250 SAE .....	34
Technical information	
F11 saw motors .....	35
F11 fan motors .....	35
F12 integrated flushing valve .....	36
F12 accessory valve blocks .....	36
Type BT brake valve .....	37
Type SR pressure relief/make-up valve .....	37
Type SV pressure relief valve .....	38
Speed sensor .....	38
F12 main port suction fittings .....	39
Suction fittings .....	39
Suction fitting kits .....	39
Split-flange kits .....	39
Installation information .....	40
Direction of rotation .....	40
Hydraulic fluids .....	40
Operating temperature .....	40
Installation information	
Viscosity .....	41
Filtration .....	41
Case pressure .....	41
Case drain connections .....	42
Before start-up .....	42

F11 and F12 are bent axis, fixed displacement heavy-duty motor/pump series. They can be used in numerous applications in both open and closed loop circuits.

- Series F11 is available in the following frame sizes and versions:
  - F11-5, -10, -14, 19 and -150 with CETOP mounting flange and shaft end
  - F11-14 with ISO flange and shaft
  - F11-14, -19, -150 and -250 with SAE flange and shaft
- Series F12 conforms to current ISO and SAE mounting flange and shaft end configurations. A very compact cartridge version is also available.
- Thanks to the unique spherical piston design, F11/F12 motors can be used at unusually high shaft speeds. Operating pressures to 480 bar provides for the high output power capability.
- The 40° angle between shaft and cylinder barrel allows for a very compact, lightweight motor/pump.

- The laminated piston ring offers important advantages such as low internal leakage and thermal shock resistance.
- The pump version has highly engineered valve plates for increased selfpriming speed and low noise, available with left and right hand rotation.
- The F11/F12 motors produce very high torque at start-up as well as at low speeds.
- Our unique timing gear design synchronizes shaft and cylinder barrel, making the F11/F12 very tolerant to high 'G' forces and torsional vibrations.
- Heavy duty roller bearings permit substantial external axial and radial shaft loads.
- The F11's and F12's have a simple and straightforward design with very few moving parts, making them very reliable motors/pumps.
- The unique piston locking, timing gear and bearing set-up as well as the limited number of parts add up to a very robust design with long service life and, above all, proven reliability.

**F11 cross section**

1. Barrel housing
2. Valve plate
3. Cylinder barrel
4. Guide spacer with O-rings
5. Timing gear
6. Roller bearing
7. Bearing housing
8. Shaft seal
9. Output/input shaft
10. Piston with laminated piston ring

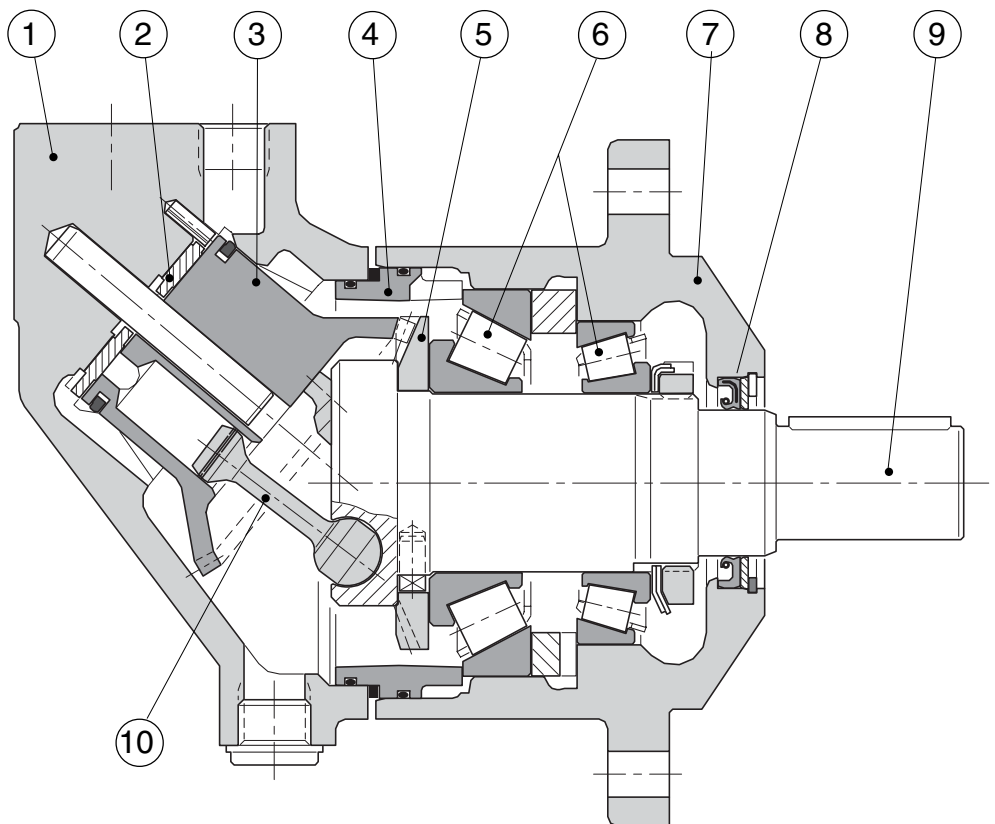

**F12 cross sections**

**F12-30, -40, -60 and -80**  
 (F12-60 shown)

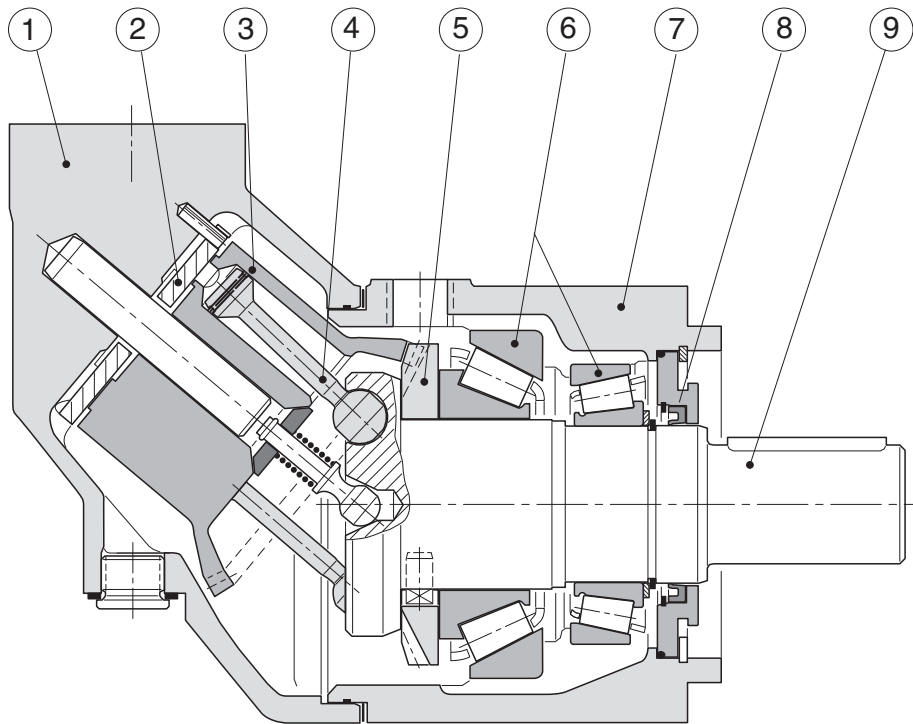

- Legend:
- |                            |                            |                               |
|----------------------------|----------------------------|-------------------------------|
| 1. Barrel housing          | 5. Timing gear             | 9. Output/input shaft         |
| 2. Valve plate             | 6. Tapered roller bearings | 10. Port E (F12-110)          |
| 3. Cylinder barrel         | 7. Bearing housing         | 11. Needle bearings (F12-110) |
| 4. Piston with piston ring | 8. Shaft seal              |                               |

**F12-110**

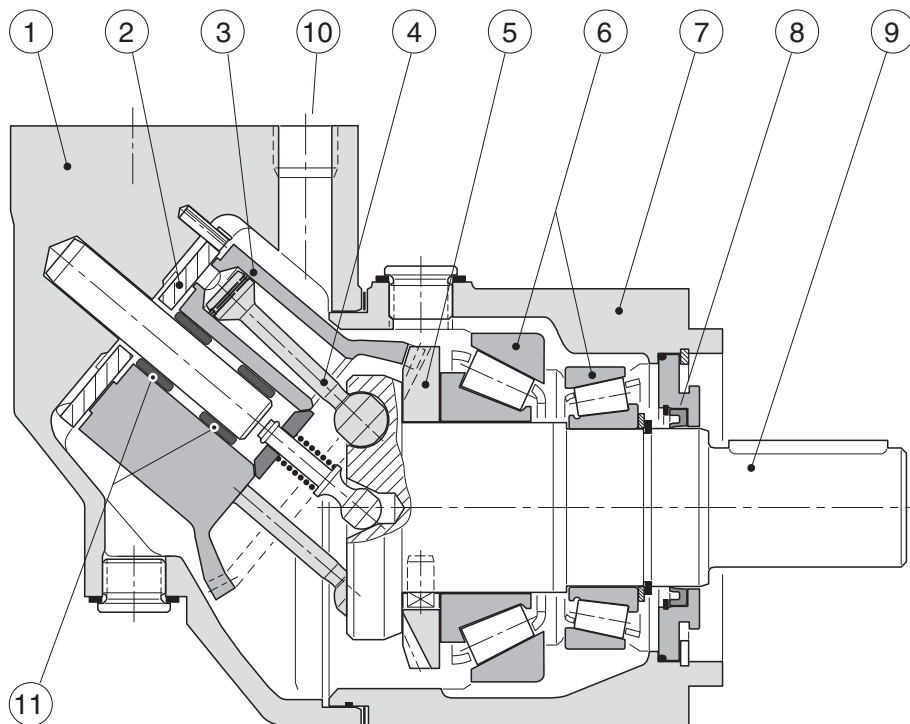

**Specifications**

Frame size	F11-5	-10	-14	-19	F12-30	-40	-60	-80	-110	F11-150	-250	
<b>Displacement</b> [cm <sup>3</sup> /rev] [cu in/rev]	4.9 0.30	9.8 0.60	14.3 0.87	19.0 1.16	30.0 1.83	40.0 2.44	59.8 3.65	80.4 4.91	110.1 6.72	150 9.15	242 14.8	
<b>Operating pressure</b>												
max intermittent <sup>1)</sup> [bar] [psi]	420 6 000	—————			420 6 000	480 7 000	—————			480 7 000	420 6 000	420 6 000
max continuous [bar] [psi]	350 5 000	—————			350 5 000	420 6000	—————			420 6000	350 5 000	350 5 000
<b>Motor operating speed</b> [rpm]												
max intermittent <sup>1)</sup>	12 000	11 000	10 000	9 000	7 100	6 400	5 600	5 200	4 700	3 000	2 700	
max continuous	10 800	9 900	9 000	8 100	5 600	5 000	4 300	4 000	3 600	2 600	2 400	
min continuous	50	—————			—————					50	—————	
<b>Max pump selfpriming speed<sup>2)</sup></b> L or R function; max [rpm]	4 600	4 200	3 900	3 500	3 150	2 870	2 500	2 300	2 290	1 700	1 500	
<b>Motor input flow</b>												
max intermittent <sup>1)</sup> [l/min] [gpm]	58 15.3	108 28.5	143 37.8	171 45.2	213 56.3	256 67.6	335 88.5	418 110.4	517 136.6	450 119.0	650 172.8	
max continuous [l/min] [gpm]	52 13.7	97 25.6	128 33.8	153 40.4	168 44.4	200 52.8	257 67.9	322 85.1	396 104.6	390 103.0	580 153.6	
<b>Main circuit temp.<sup>3)</sup>, max</b> [°C] [°F]	80 175	—————			—————					80 175	—————	
min [°C] [°F]	-35 -31	-35 -31	-30 -22	-35 -31	-35 -31			-35 -31		-35 -31	-35 -31	
<b>Mass moment of inertia</b>												
(x10 <sup>-3</sup> ) [kg m <sup>2</sup> ] (x10 <sup>-2</sup> ) [lbf ft <sup>2</sup> ]	0.16 0.38	0.39 0.92	0.42 1.00	1.1 2.61	1.7 4.03	2.9 6.88	5 11.86	8.4 19.93	11.2 26.58	40 94.92	46 109.16	
<b>Weight</b> [kg] [lb]	5 11	7.5 16.5	8.3 18.8	11 24	12 26	16.5 36	21 46	26 57	36 79	70 154	77 170	

- 1) Intermittent: max 6 seconds in any one minute.
- 2) Selfpriming speed valid at sea level.
- 3) See also installation information, operating temperature.

**Basic formulas for hydraulic motors**

Flow (q)

$$q = \frac{D \times n}{1000 \times \eta_v} \text{ [l/min]}$$

D - displacement [cm<sup>3</sup>/rev]

n - shaft speed [rpm]

$\eta_v$  - volumetric efficiency

$\Delta p$  - differential pressure [bar]  
(between inlet and outlet)

$\eta_{hm}$  - mechanical efficiency

$\eta_t$  - overall efficiency

( $\eta_t = \eta_v \times \eta_{hm}$ )

Torque (M)

$$M = \frac{D \times \Delta p \times \eta_{hm}}{63} \text{ [Nm]}$$

Power (P)

$$P = \frac{q \times \Delta p \times \eta_t}{600} \text{ [kW]}$$

**Ordering codes**

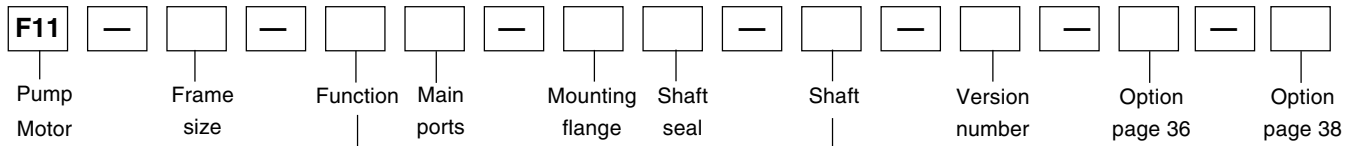

**F11-CETOP**

Frame size	
Code	Displacem. (cm <sup>3</sup> /rev)
5	4.9
10	9.8
14	14.3
19	19.0
150	150.0

Version number
(assigned for special versions)

Option
None

Frame size		5	10	14	19	150
Code	Function					
M	Motor	x	x	-	x	x
H	Motor, high pressure	x	x	x	x	x
Q	Motor, silent	(x)	(x)	-	(x)	(x)
J	Motor, clockwise rot'n <sup>1)</sup>	(x)	(x)	-	(x)	(x)
G	Motor, counter clockw. <sup>1)</sup>	(x)	(x)	-	(x)	(x)
R	Pump, clockwise rot'n	x	x	x	x	x
L	Pump, counter clockw.	x	x	x	x	x

Frame size		5	10	14	19	150
Code	Shaft					
K	Metric key	x	x	x	x	x
D	Spline, DIN 5480	(x)	(x)	(x)	(x)	(x)

Frame size		5	10	14	19	150
Code	Main ports					
B	BSP threads	x	x	x	x	-
R	With anti-cavitation valve; clockwise rot'n <sup>2)</sup>	-	x	x	x	-
L	With anti-cavitation valve; counter clockw. <sup>2)</sup>	-	x	x	x	-
U	SAE, UN threads	(x)	(x)	-	(x)	-
F	SAE 6000 psi flange	-	-	-	-	x

Frame size		5	10	14	19	150
Code	Shaft seal					
N	NBR <sup>3)</sup> , low pressure	x	x	-	x	x
H	NBR <sup>3)</sup> , high pressure	x	x	-	x	x
E	FPM <sup>4)</sup> , low pressure, high temperature	x	x	x	x	x
V	FPM <sup>4)</sup> , high pressure, high temperature	-	x	x	x	-

Frame size		5	10	14	19	150
Code	Mounting flange					
C	CETOP flange	x	x	x	x	x
W	Saw motor flange	-	x	x	x	-

Frame size		5	10	14	19	150
Code	Option					
S	With speed sensor	-	-	x	x	-
P	Prepared for speed sensor	-	-	x	x	-

- x: Available      (x): Optional      -: Not available
- 1) Internal drain
- 2) BSP threads
- 3) NBR - Nitrile rubber
- 4) FPM - Fluor rubber

**Ordering codes**

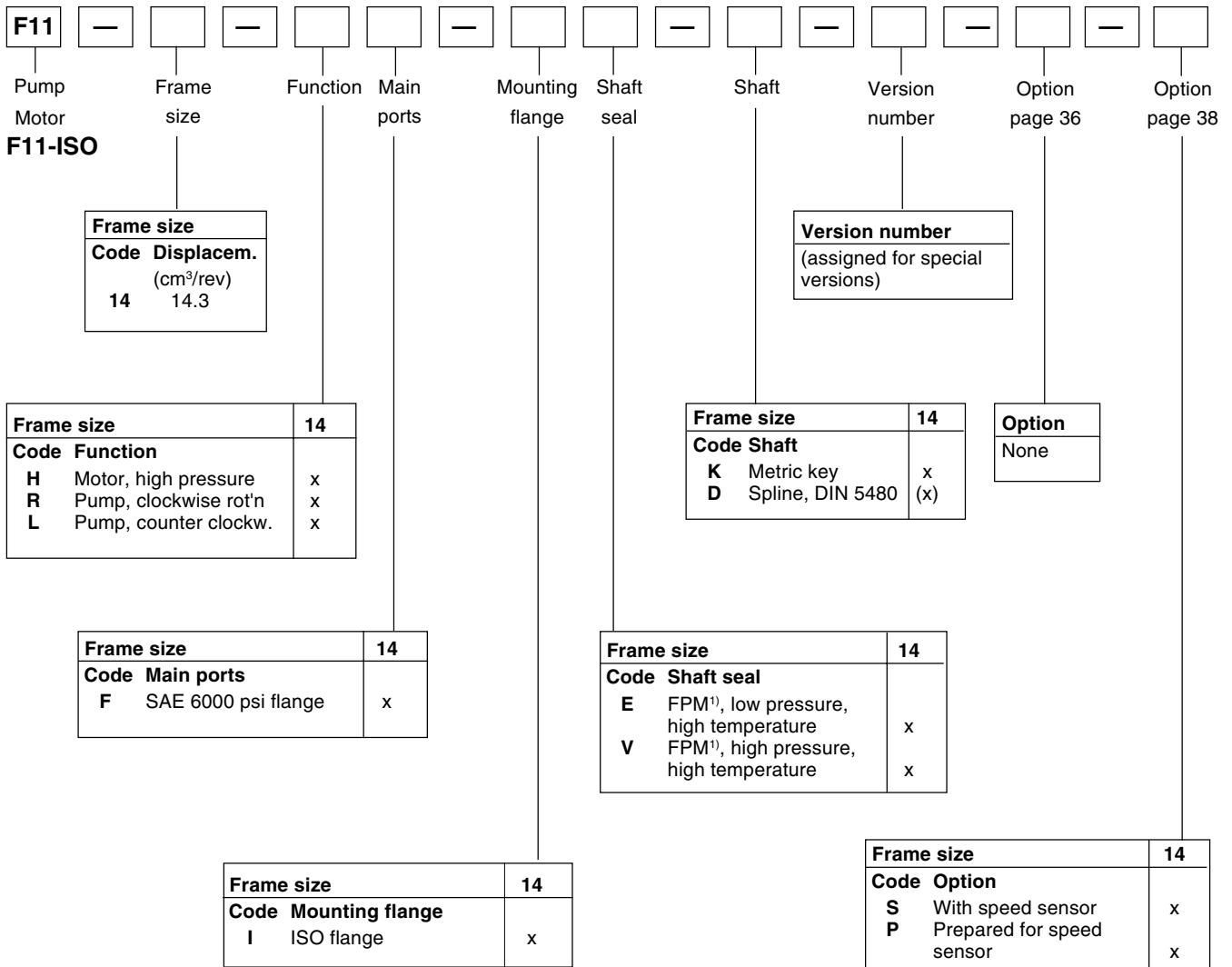

x: Available      (x): Optional      - : Not available  
 1) FPM - Fluor rubber



**Ordering codes**

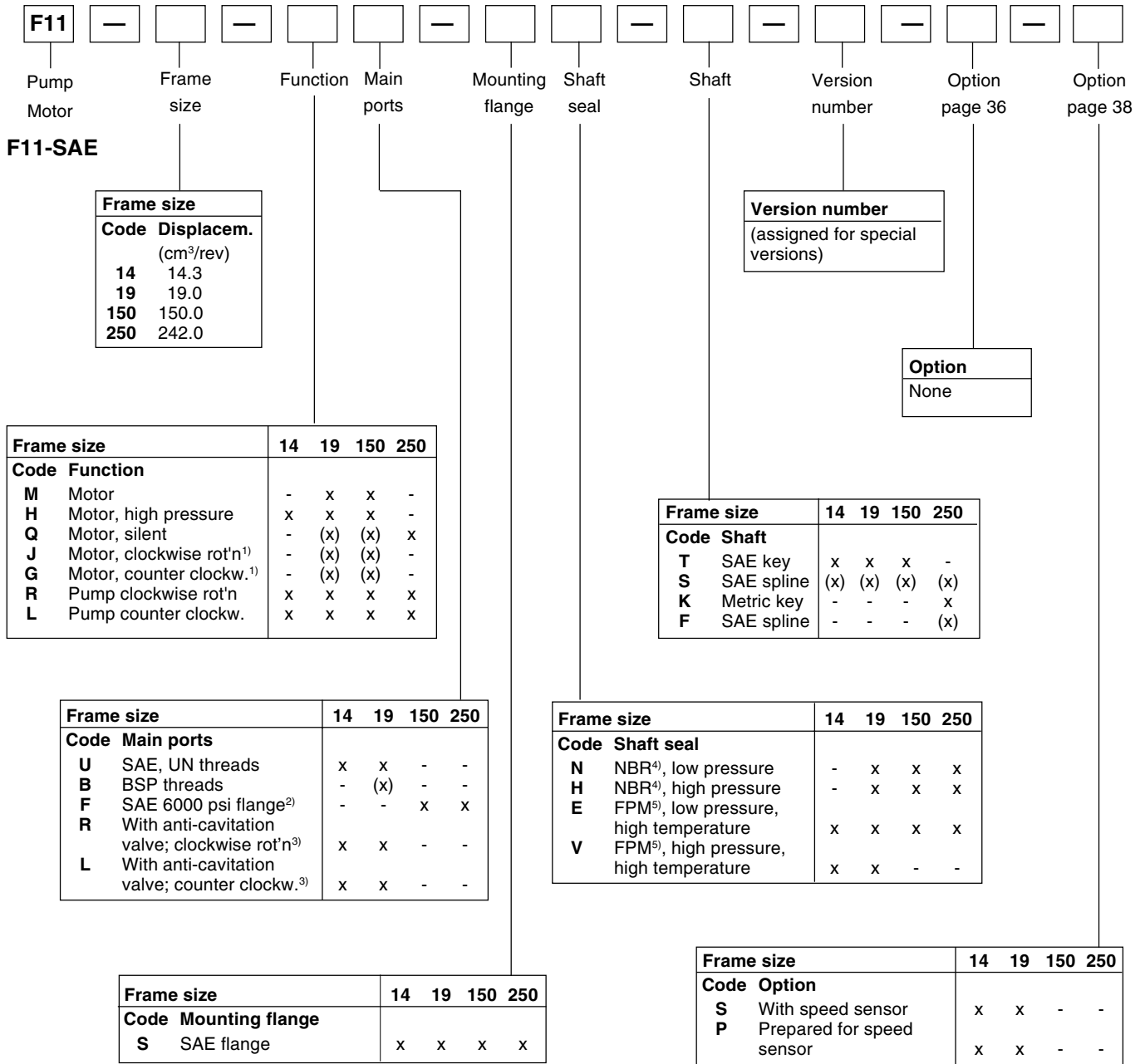

- x: Available      (x): Optional      -: Not available
- 1) Internal drain
  - 2) Metric thread
  - 3) BSP threads
  - 4) NBR - Nitrile rubber
  - 5) FPM - Fluor rubber

Ordering codes

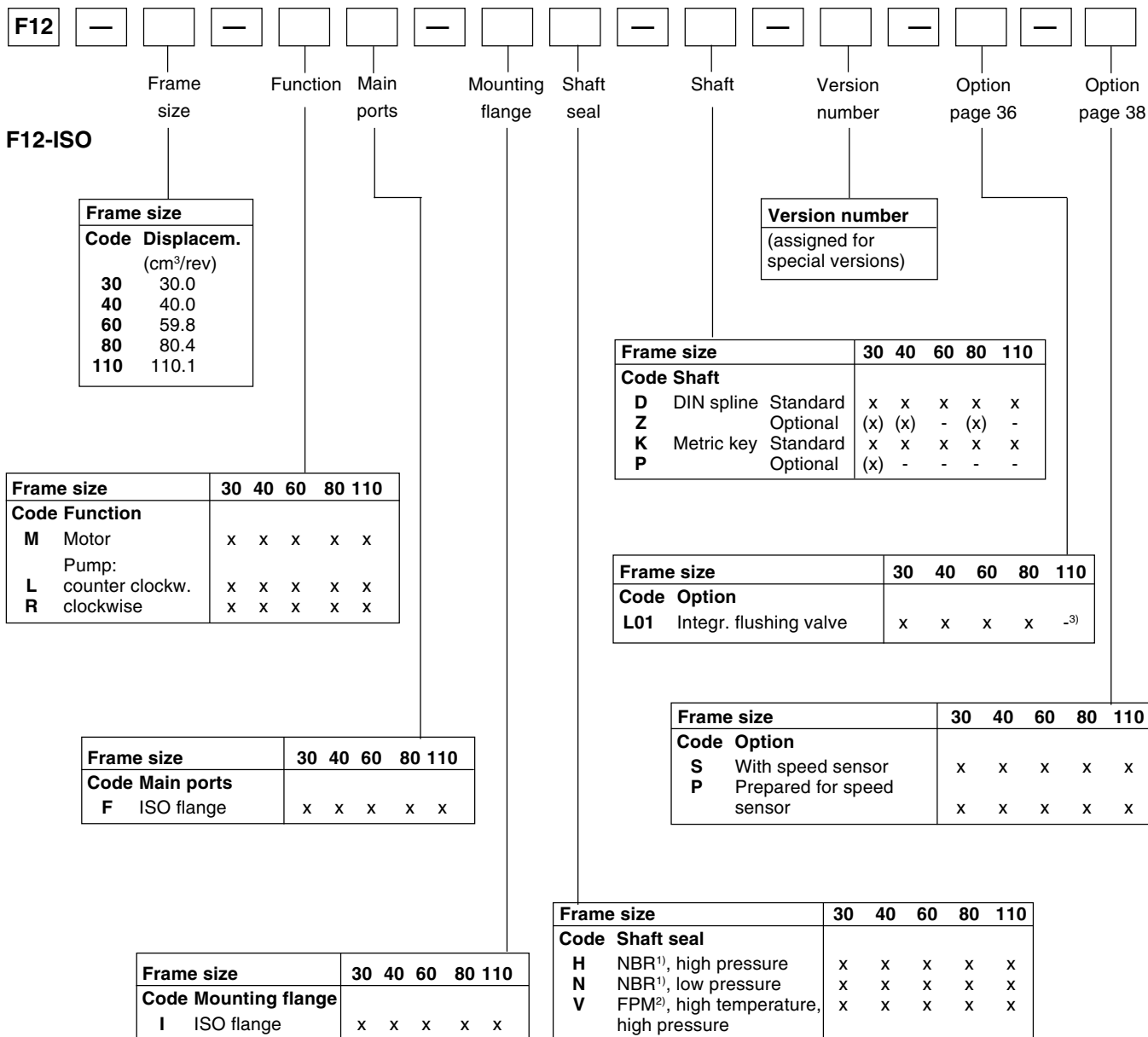

x: Available      (x): Optional      -: Not available

1) NBR - Nitrile rubber

2) FPM - Fluor rubber

3) F12-110: Accessory valve block (page 36)

**Ordering codes**

**Series F11/F12**

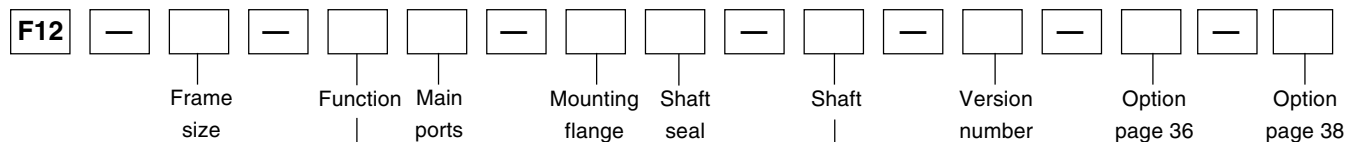

**F12-Cartridge**

Frame size	
Code	Displacem. (cm <sup>3</sup> /rev)
30	30.0
40	40.0
60	59.8
80	80.4
110	110.1

**Version number**  
(assigned for special versions)

Frame size		30	40	60	80	110
Code	Shaft					
C	DIN spline Standard	x	x	x	x	x
K	Metric key Standard	x	-	x	x	-
X	" " Optional	-	(x)	-	-	-

Frame size		30	40	60	80	110
Code	Function					
M	Motor	x	x	x	x	x

Frame size		30	40	60	80	110
Code	Option					
L01	Integr. flushing valve	x	x	x	x	- <sup>3)</sup>

Frame size		30	40	60	80	110
Code	Main ports					
F	ISO flange	x	x	x	x	x

Frame size		30	40	60	80	110
Code	Option					
S	With speed sensor	x	x	x	x	x
P	Prepared for speed sensor	x	x	x	x	x

Frame size		30	40	60	80	110
Code	Mounting flange					
C	Cartridge	x	x	x	x	x

Frame size		30	40	60	80	110
Code	Shaft seal					
H	NBR <sup>1)</sup> , high pressure	x	x	x	x	x
N	NBR <sup>1)</sup> , low pressure	x	x	x	x	x
V	FPM <sup>2)</sup> high temperature, high pressure)	x	x	x	x	x

x: Available      (x): Optional      -: Not available

1) NBR - Nitrile rubber

2) FPM - Fluor rubber

3) F12-110: Accessory valve block (page 36)

Ordering codes

**F12** [ ] [ ] [ ] [ ] [ ] [ ] [ ] [ ] [ ] [ ] [ ] [ ] [ ] [ ] [ ] [ ]

Frame size    Function    Main ports    Mounting flange    Shaft seal    Shaft    Version number    Option page 36    Option page 38

**F12-SAE**

Frame size	
Code	Displacem. (cm³/rev)
30	30.0
40	40.0
60	59.8
80	80.4
110	110.1

Code	Function	30	40	60	80	110
M	Motor	x	x	x	x	x
L	Pump: counter clockw.	x	x	x	x	x
R	clockwise	x	x	x	x	x

Code	Main ports	30	40	60	80	110
S	SAE flange	x	x	x	x	x
U	SAE, UN threads	(x)	(x)	(x)	-	(x)

Code	Shaft seal	30	40	60	80	110
H	NBR <sup>1)</sup> , high pressure	x	x	x	x	x
N	NBR <sup>1)</sup> , low pressure	x	x	x	x	x
V	FPM <sup>2)</sup> , high temperature, high pressure	x	x	x	x	x

Code	Option	30	40	60	80	110
L01	Integr. flushing valve	x	x	x	x	- <sup>3)</sup>

Code	Option	30	40	60	80	110
S	With speed sensor	x	x	x	x	x
P	Prepared for speed sensor	x	x	x	x	x

Code	Shaft	30	40	60	80	110
S	SAE spline Standard	x	x	x	x	x
U	" " Optional	-	-	-	(x)	-
T	SAE key Standard	x	x	x	x	x

Code	Version number	30	40	60	80	110
	(assigned for special versions)					

x: Available    (x): Optional    -: Not available

1) NBR - Nitrile rubber

2) FPM - Fluor rubber

3) F12-110: Accessory valve block (page 36)

**Preferred versions F11/F12 catalogue****F11**

<b>Ordering Codes</b>	<b>Part number</b>
F11-005-MB-CN-K	3703665
F11-005-MB-CH-K	3707249
F11-005-HU-CH-K	3707308
F11-010-MB-CN-K	3703603
F11-010-MB-CH-K	3706030
F11-010-HU-CH-K	3707310
F11-014-HB-CE-K	3783201
F11-014-HB-CV-K	3782830
F11-019-MB-CN-K	3703516
F11-019-MB-CH-K	3707893
F11-150-MF-CN-K	3703468
F11-150-MF-CH-K	3707008
F11-150-HF-SH-S	3707325
F11-250-QF-SH-F	3706440
F11-250-QF-SH-K	3795858

**F12**

<b>Ordering Codes</b>	<b>Part number</b>
F12-30-MF-IH-D	3799843
F12-30-MF-IH-K	3799844
F12-30-MS-SH-S	3799851
F12-30-MS-TH-S	3799616
F12-40-MF-IH-D	3799525
F12-40-MF-IH-K	3799526
F12-40-MS-SH-S	3799532
F12-40-MS-SH-T	3799533
F12-40-MS-TH-S	3799617
F12-60-MF-IH-D	3799988
F12-60-MF-IH-K	3799989
F12-60-MS-SH-S	3799998
F12-60-MS-TH-S	3799618
F12-80-MF-IH-D	3780767
F12-80-MF-IH-K	3780772
F12-80-MS-SH-S	3780783
F12-110-MF-IH-D	3781530
F12-110-MF-IH-K	3781534
F12-110-MS-SH-S	3781542

## Bearing life

### General information

Bearing life can be calculated for that part of the load/ life curve (shown below) that is designated 'Bearing fatigue'. 'Rotating group fatigue and wear' and 'Other' caused by material fatigue, fluid contamination, etc. should also be taken into consideration when estimating the service life of a motor/pump in a specific application.

Bearing life calculations are mainly used when comparing different frame sizes. Bearing life, designated  $B_{10}$  (or  $L_{10}$ ), is dependent of system pressure, operating speed, external shaft loads, fluid viscosity in the case, and fluid contamination level.

The  $B_{10}$  value means that 90% of the bearings survive, at a minimum, the number of hours calculated. Statistically, 50% of the bearings will survive at least five times the  $B_{10}$  life.

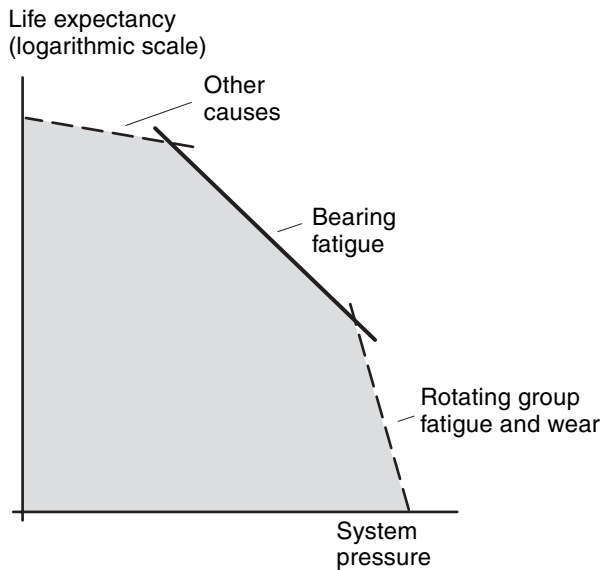

Hydraulic unit life versus system pressure.

### Bearing life calculation

An application is usually governed by a certain duty or work cycle where pressure and speed vary with time during the cycle.

In addition, bearing life depends on external shaft forces, fluid viscosity in the case and fluid contamination.

Parker Hannifin (Mobile Controls Division) has a computer program for calculating bearing life and will assist in determining F11 or F12 motor/pump life in a specific application.

### Required information

When requesting a bearing life calculation from Parker Hannifin (Mobile Controls Division), the following information (where applicable) should be provided:

- A short presentation of the application
- F11 or F12 size and version
- Duty cycle (pressure and speed versus time at given displacements)
- Low system pressure
- Case fluid viscosity
- Life probability ( $B_{10}$ ,  $B_{20}$ , etc.)
- Operating mode (pump or motor)
- Direction of rotation (L or R)
- External shaft loads
- Fixed or rotating radial load
- Distance between flange and radial load
- Angle of attack ( $\alpha$ ) as defined below

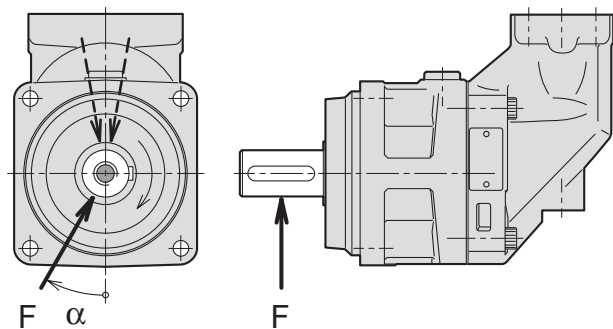

The direction (a) of the radial load is positive in the direction of rotation as shown.

To obtain maximum bearing life, the radial load should, in most cases, be located approximately at  $170^\circ$  (motor; R.H. rot'n) or  $190^\circ$  (pump; R.H rot'n).

**Efficiency**

Because of its high overall efficiency, driving a motor/pump from series F11/F12 requires less fuel or electric power. Also, it allows the use of a small reservoir and heat exchanger, which in turn reduce cost, weight, and installation size.

The diagrams to the right shows volumetric and mechanical efficiencies of an F12-30.

Contact Parker Hannifin for efficiency information on a particular F11/F12 frame size that is being considered.

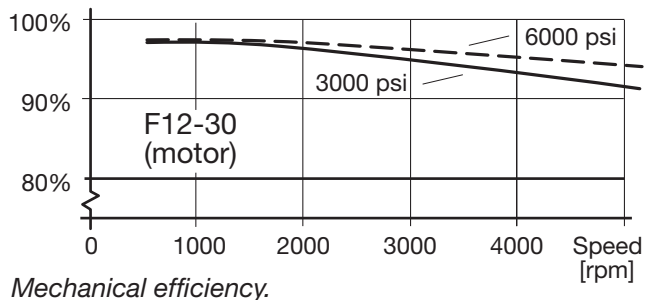
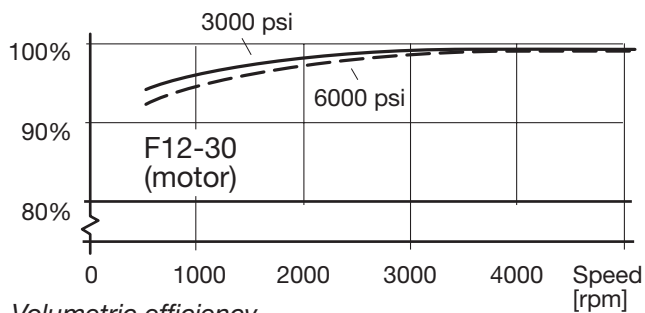

**Noise level**

Series F11/F12 feature low noise levels from low to high speeds and pressures.

As an example, the diagram to the right shows the noise level of an F12-30.

The noise level is measured in a semi-anechoic room, 1 m behind the unit.

The noise level for a particular motor/pump may vary  $\pm 2$  dB(A) compared to what is shown in the diagram.

**NOTE:** Noise information for F11/F12 frame sizes are available from Parker Hannifin.

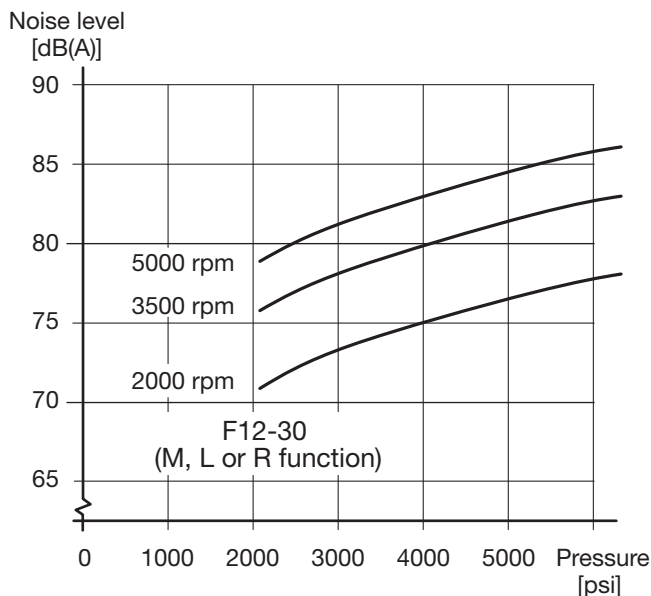

**Selfpriming speed and required inlet pressure**

**Series F11**

In pump applications, the F11 with function **L** (counter clockwise rotation) or **R** (clockwise rotation) is normally used. The **L** and **R** (pump) provide the highest self-priming speeds (see table) as well as the lowest noise level. The **M** (motor) function can also be used as a pump, in either direction, but at a lower selfpriming speed.

Operating above the selfpriming speed (refer to Diagram 1) requires increased inlet pressure.

As an example, at least 1.0 bar is needed when operating the F11-19-M as a pump at 3500 rpm. An F11 with **H** function, used as a motor (e.g. in a hydrostatic transmission), may sometimes operate as a pump at speeds above the selfpriming speed; this requires additional inlet pressure.

Insufficient inlet pressure can cause pump cavitation resulting in greatly increased pump noise and deteriorating performance.

Function	L or R	M	H
F11-5	4600	3800	3200
F11-10	4200	3100	2700
F11-14	3900	-	3200
F11-19	3500	2400	2100
F11-150	1700	1300	1100
F11-250	1500	950	-

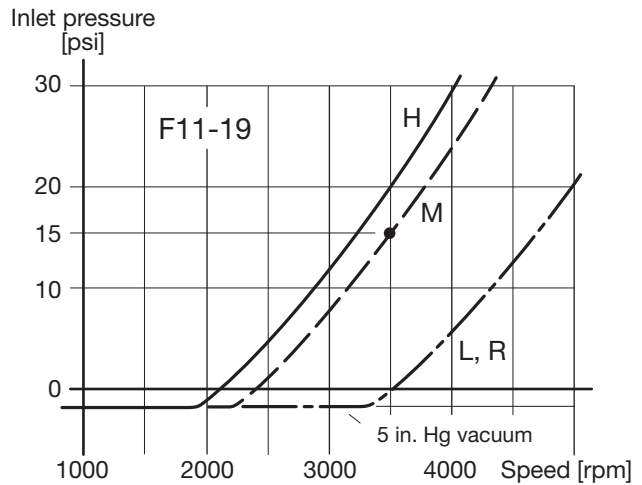
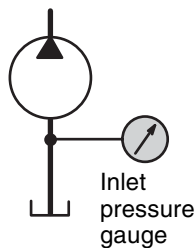

Diagram 1. Min required inlet pressure (F11-19).

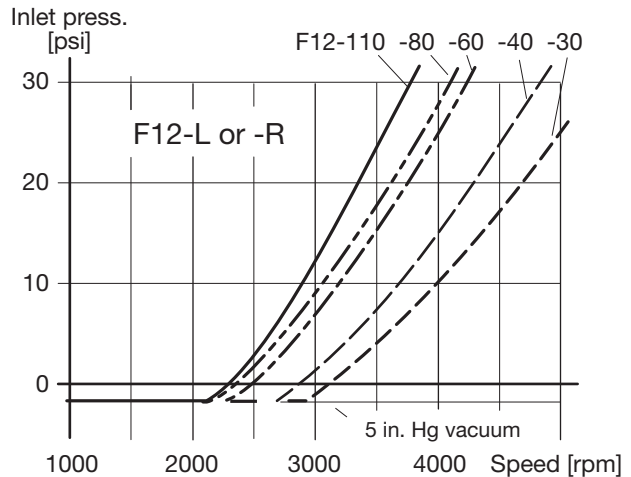

Diagram 2. Min. required pump (F12-L or -R) inlet press.

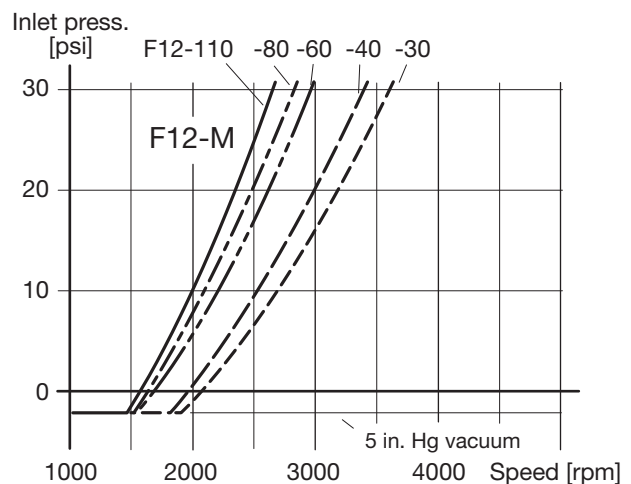

Diagram 3. Min. required motor (F12-M) inlet pressure.

**Series F12**

When operating the F12 as a pump (with **L** or **R** valve plate) above the selfpriming speed, the inlet must be pressurized. Increased noise and deteriorating performance may otherwise be experienced.

Diagrams 2 and 3 show required pump inlet pressure vs. shaft speed.

The F12 motor (type **M** valve plate) sometimes operates as a pump e.g. when used in a propel transmission and the vehicle is going downhill.

Minimum required inlet pressure versus shaft speed is shown in the diagrams.

**NOTE:** Diagrams 1, 2 and 3 are valid at sea level.



**F11-5**  
 (CETOP versions)

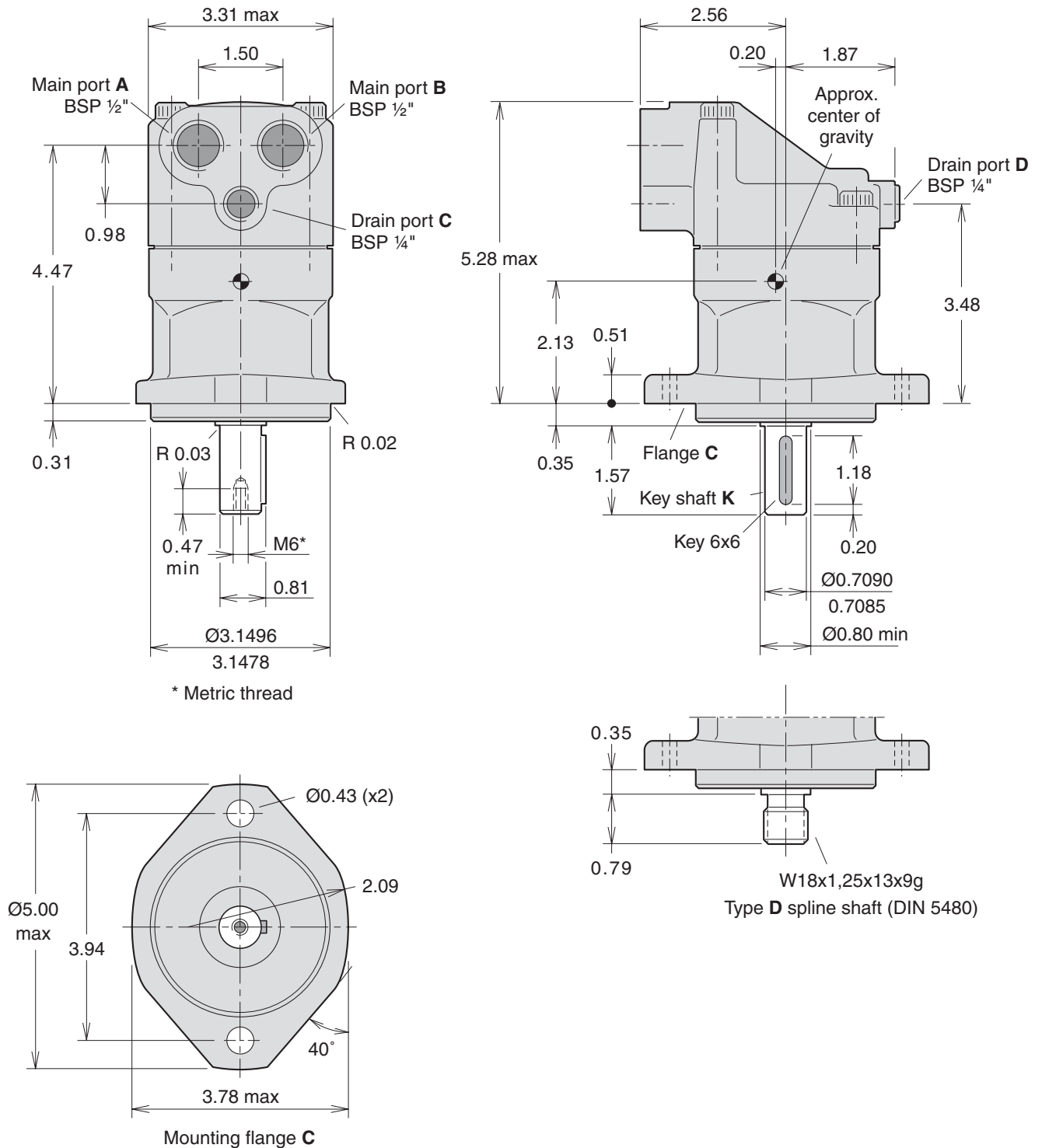

**F11-10**  
 (CETOP versions)

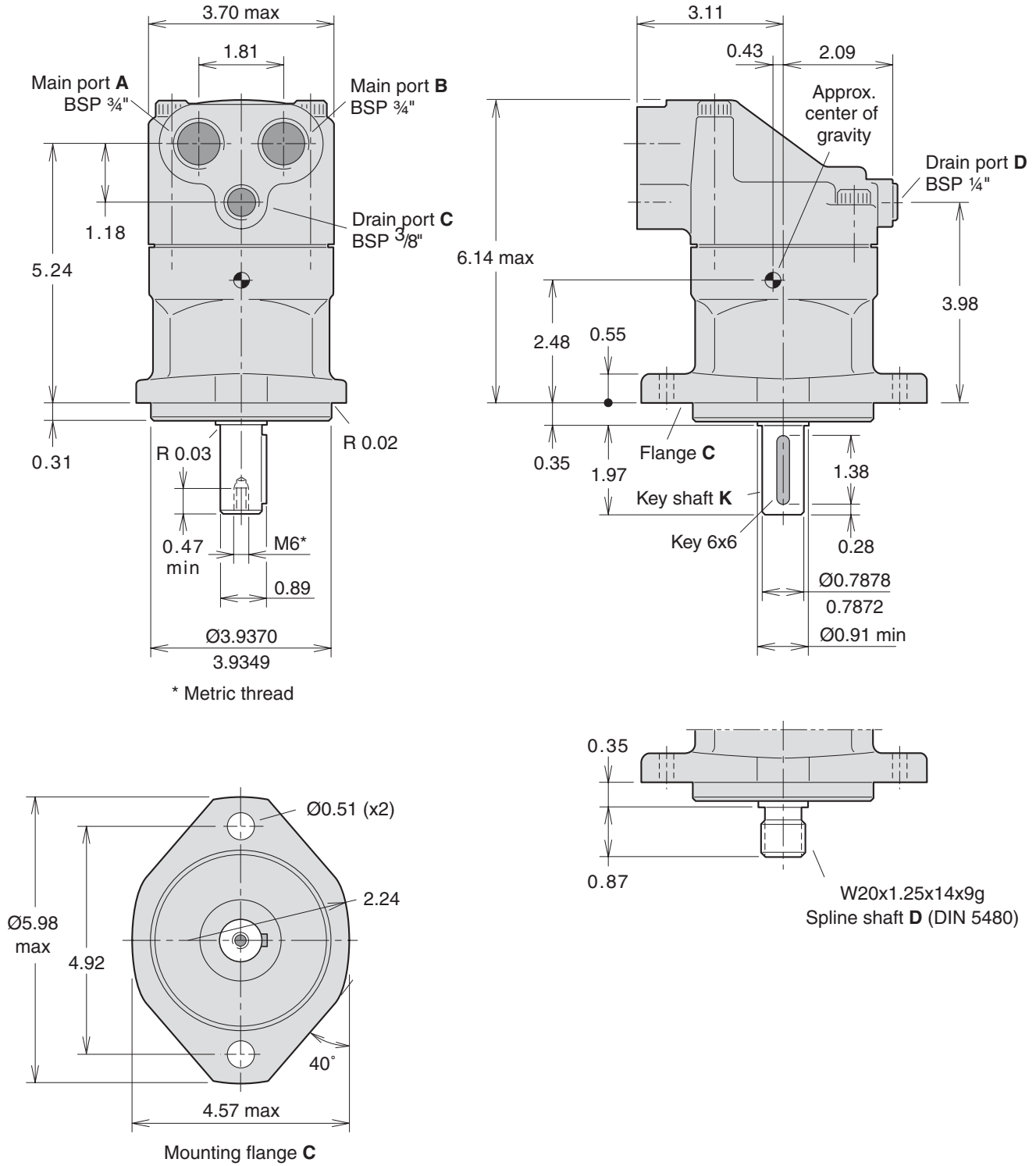

**F11-14**

(CETOP versions)

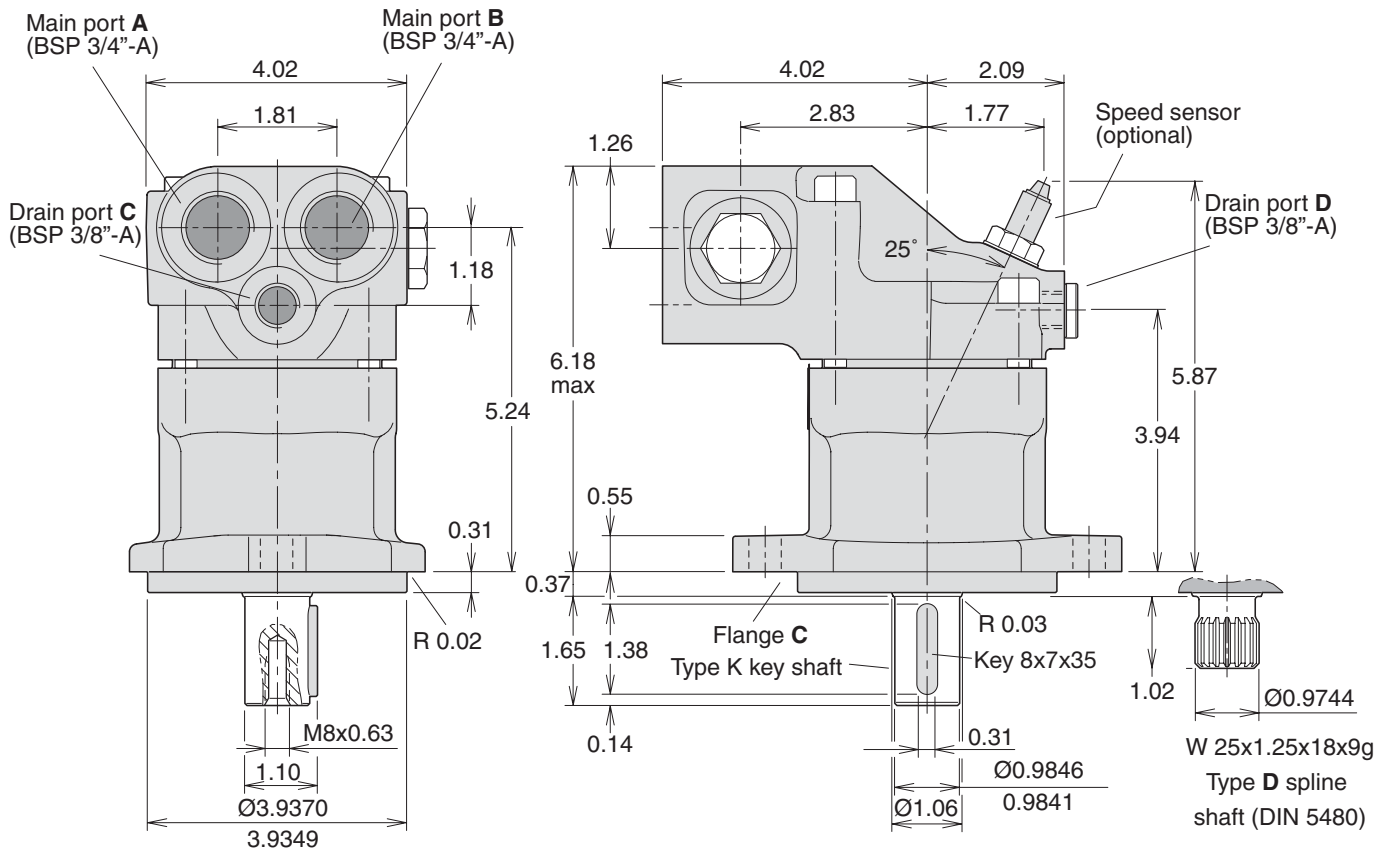

Anticavitation valve  
 (left or right hand optional;  
 right hand shown)

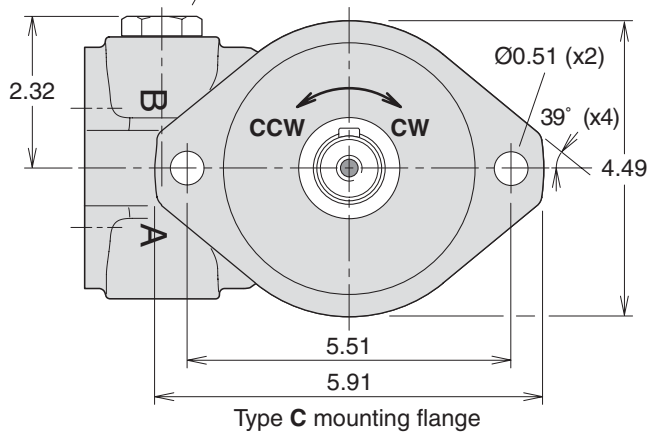

**F11-19**  
 (CETOP version)

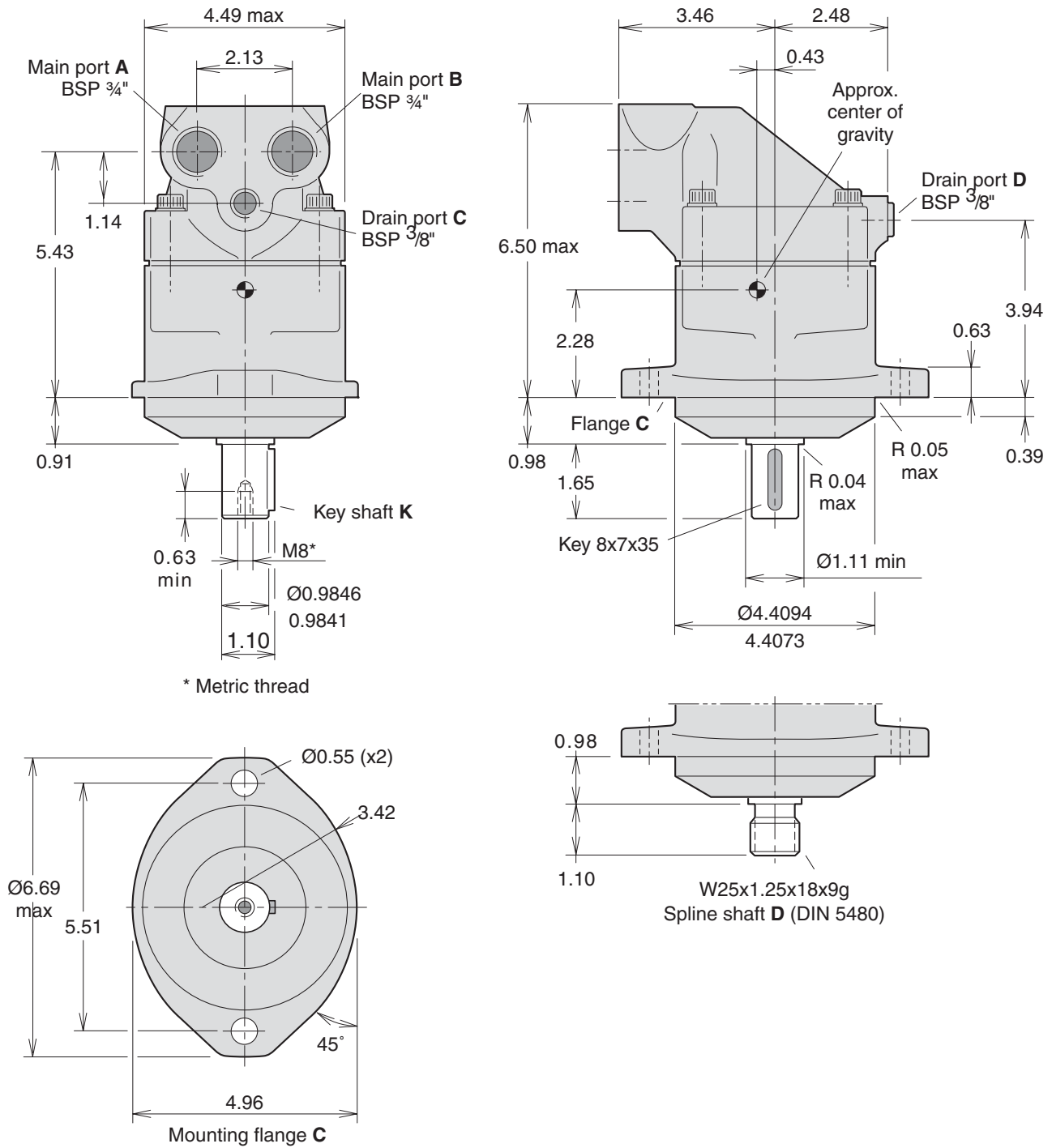

**F11-14**  
 (ISO versions)

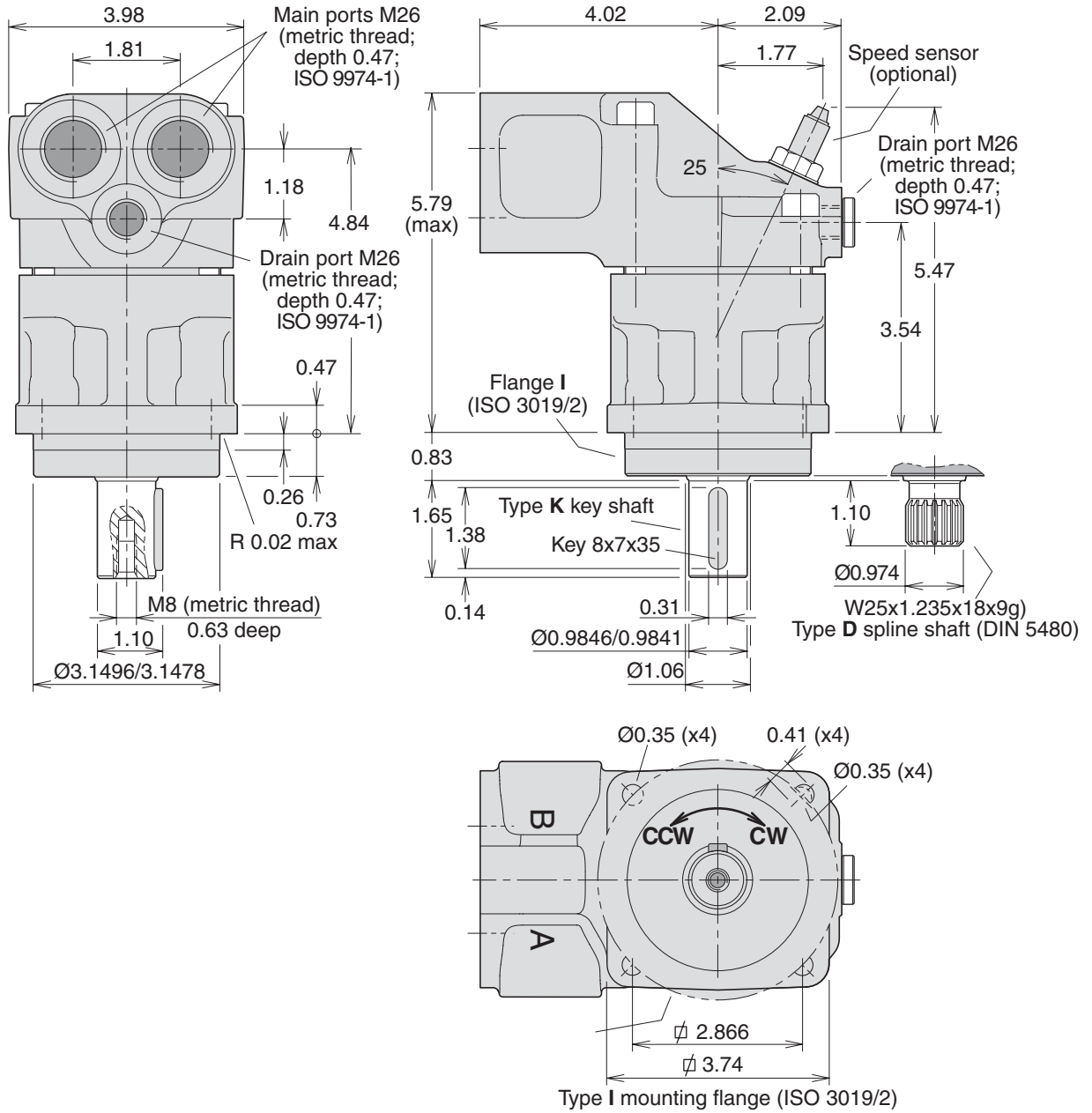

**F11-14**

(SAE versions)

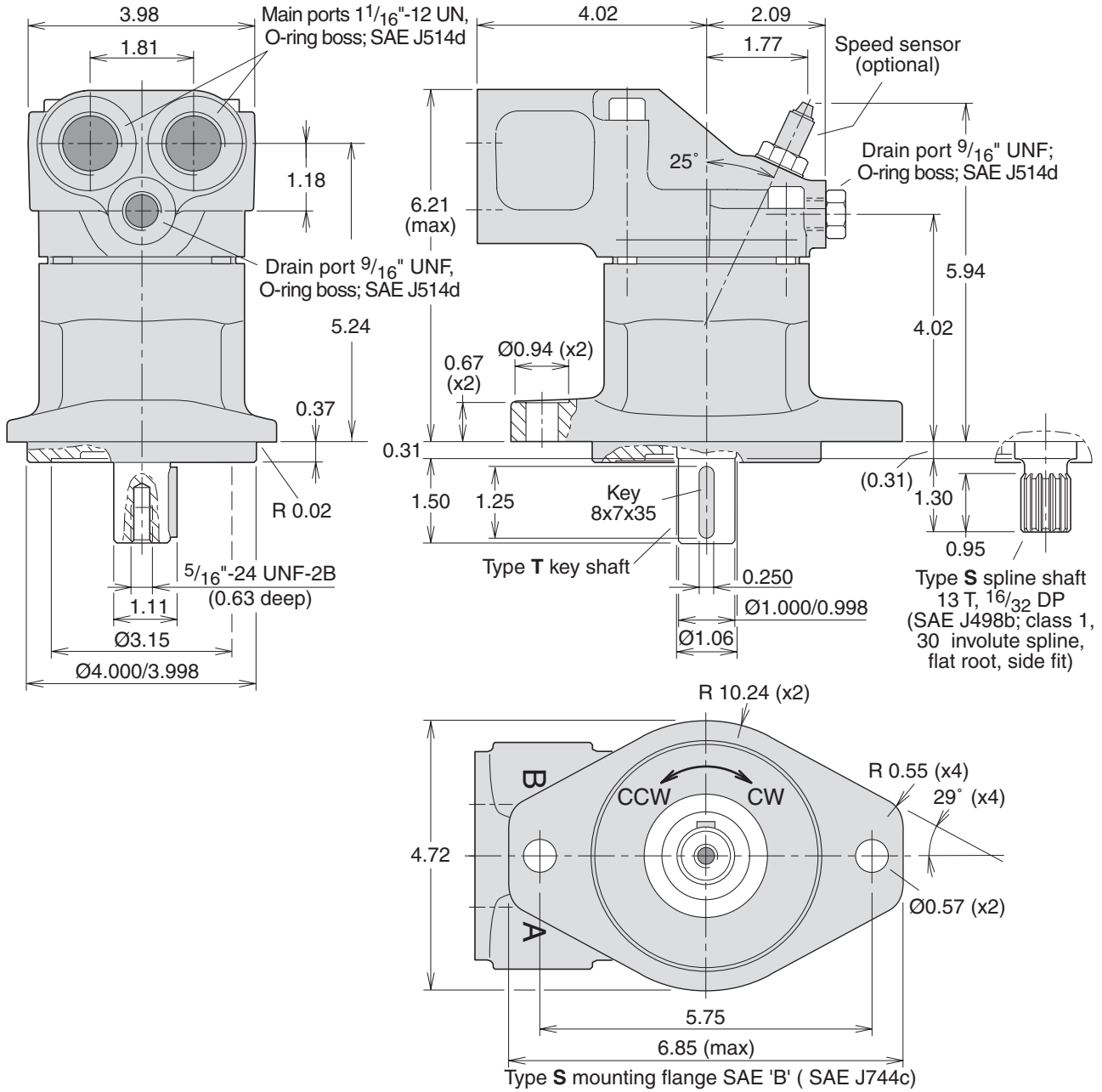

**F11-19**

(SAE version)

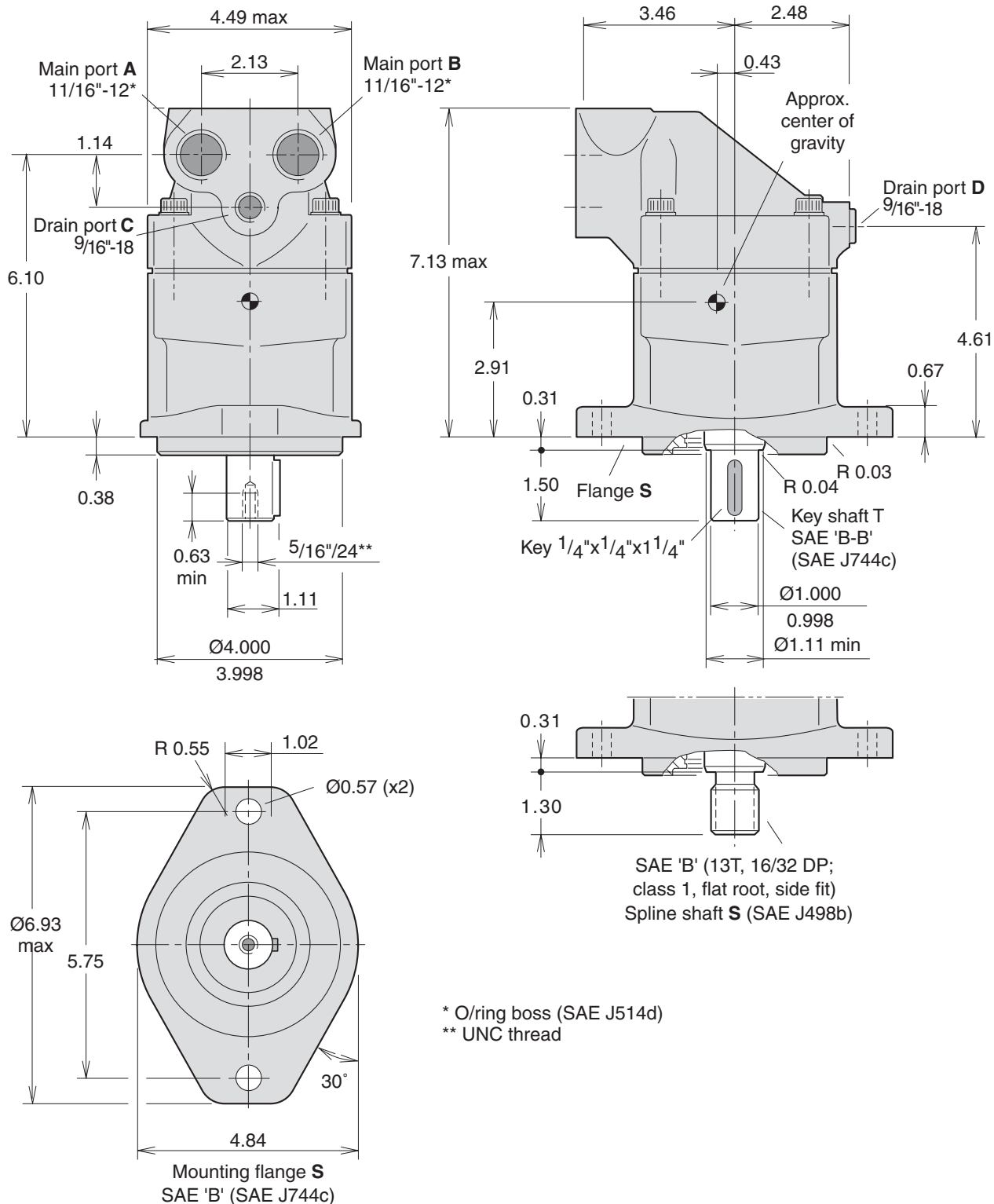

\* O/ring boss (SAE J514d)  
 \*\* UNC thread

**F12-30, -40, -60, -80 and -110**  
 (ISO versions)

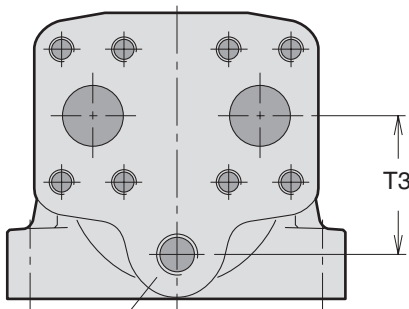
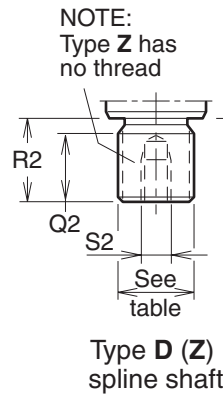
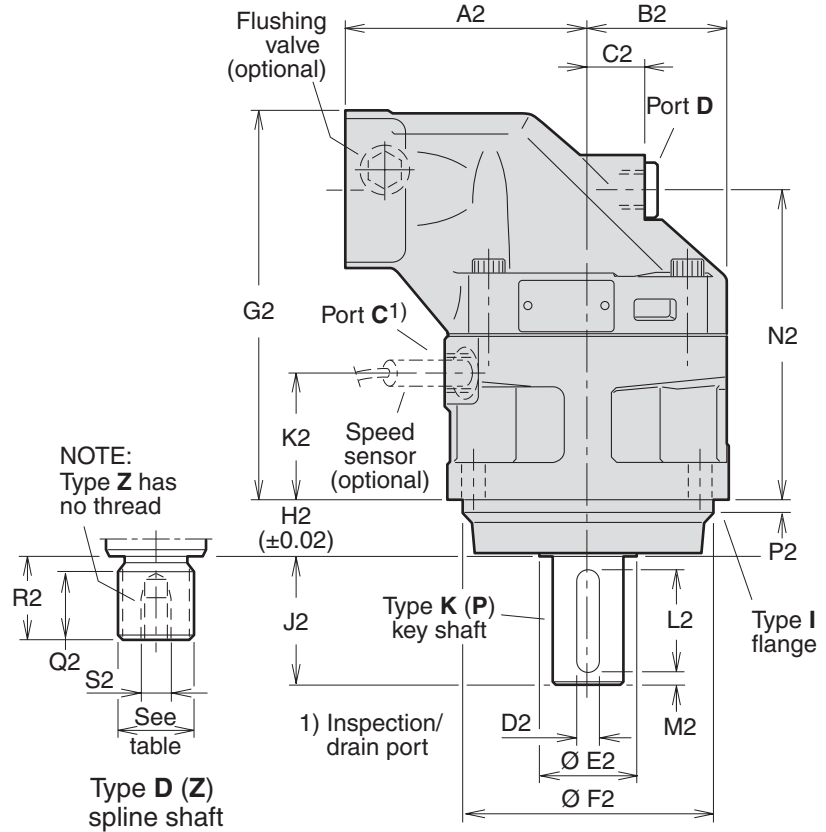
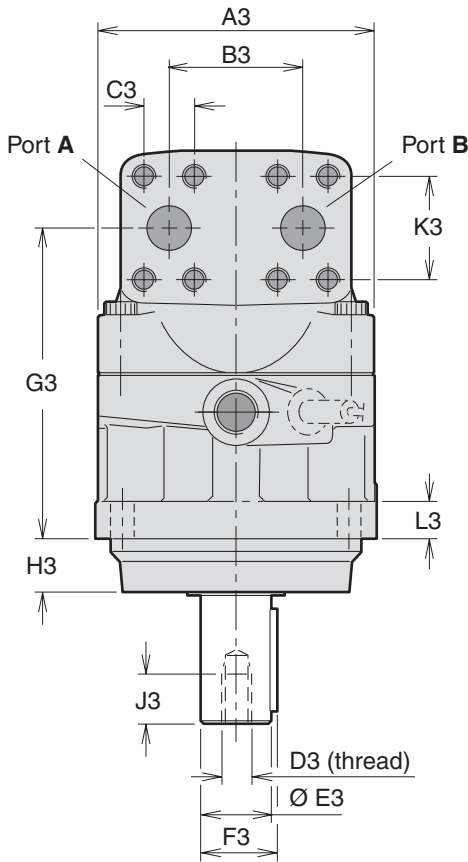

Port E (third drain port)  
 F12-110 barrel housing  
 (ISO/cartridge version)

Shown: F12-80

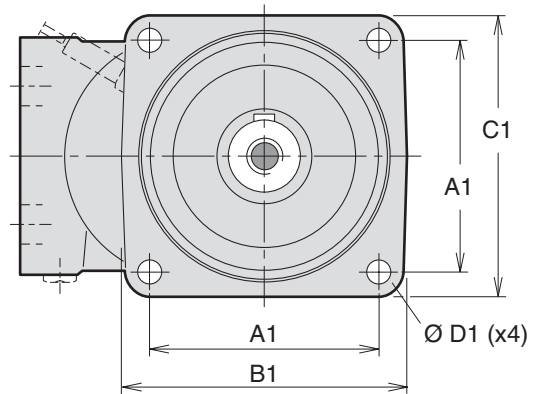

Type I mounting flange  
 (ISO 3019/2)



Dim.	F12-30	F12-40	F12-60	F12-80	F12-110
A1	3.48	4.46	4.46	5.01	5.57
B1	4.65	5.75	5.75	6.22	7.09
C1	4.65	5.59	5.67	6.10	7.09
D1	0.43	0.53	0.53	0.53	0.71
A2	3.94	4.33	4.92	5.32	5.71
B2	2.32	2.56	2.76	3.05	3.35
C2	0.98	1.02	0.87	1.26	1.50
D2	0.32	0.32	0.39	0.47	0.55
E2	1.30	1.65	1.65	2.05	2.26
F2	3.9370/ 3.9349	4.9213/ 4.9188	4.9213/ 4.9188	5.5118/ 5.5093	6.2992/ 6.2967
G2	6.77	6.81	7.48	8.50	9.09
H2	1.00	1.28	1.28	1.28	1.59
J2 <sup>1)</sup>	1.97	2.36	2.36	2.76	3.23
J2 <sup>2)</sup>	1.97	-	-	-	-
K2	2.16	2.05	2.13	2.76	2.61
L2	1.58	1.97	1.97	2.21	2.76
M2	0.20	0.20	0.20	0.28	0.24
N2	5.37	5.39	6.06	6.79	7.05
P2	0.32	0.32	0.32	0.32	0.32
Q2	1.10	1.10	1.30	1.42	1.61
R2 <sup>3)</sup>	1.38	1.38	1.61	1.77	1.97
R2 <sup>4)</sup>	1.69	1.38	-	1.61	-
S2 <sup>3)</sup>	M12 x24	M12 x24	M12 x28	M16 x36	M16 x36
A3	4.80	5.28	5.67	6.10	6.69
B3	2.60	2.60	2.60	2.95	3.29
C3	0.937	0.937	0.937	1.094	1.250
D3*	M12	M12	M12	M16	M16
E3	1.1817/ 1.1812	1.1817/ 1.1812	1.3787/ 1.3780	1.5755/ 1.5749	1.7724/ 1.7717
F3	1.30	1.30	1.50	1.69	1.91
G3	5.37	5.39	6.06	6.79	7.05
H3	0.93	1.20	1.20	1.20	1.52
J3	0.95	0.95	1.10	1.42	1.42
K3	2.000	2.000	2.000	2.250	2.626
L3	0.71	0.79	0.79	0.79	0.87
S3	0.63	0.63	0.63	1.02	-
T3	-	-	-	-	2.68

\* Metric thread

1) Key shaft type K

2) " " " P

3) Spline shaft type D

4) " " " Z.

Ports	F12-30	F12-40	F12-60	F12-80	F12-110
A, B size	3/4"	3/4"	3/4"	1"	1 1/4"
Screw thread <sup>1)</sup>	M10 (0.79)	M10 (0.79)	M10 (0.79)	M12 (0.79)	M14 (1.02)
C, D thread <sup>2)</sup>	M22 x1.5	M22 x1.5	M22 x1.5	M22 x1.5	M22 x1.5
E thread <sup>2)</sup>	-	-	-	-	M22 x1.5

A, B: ISO 6162

1) Metric thread (depth in inches)

2) Metric thread x pitch in mm.

**Spline shaft (DIN 5480; in mm)**

	Type D (standard)	Type Z (optional)
F12-30	W30x2x14x9g	W25x1.25x18x9g
-40	W32x2x14x9g	W30x2x14x9g
-60	W35x2x16x9g	W32x2x14x9g
-80	W40x2x18x9g	W35x2x16x9g
-110	W45x2x21x9g	-

**Metric key shaft (in mm)**

	Type K (standard)	Type P (optional)
F12-30	30 dia.	25 dia.
-40	30 dia.	-
-60	35 dia.	-
-80	40 dia.	-
-110	45 dia.	-

 = Max 5 100 psi (350 bar) operating pressure.

**F12-30, -40, -60, -80 and -110**  
 (Cartridge versions)

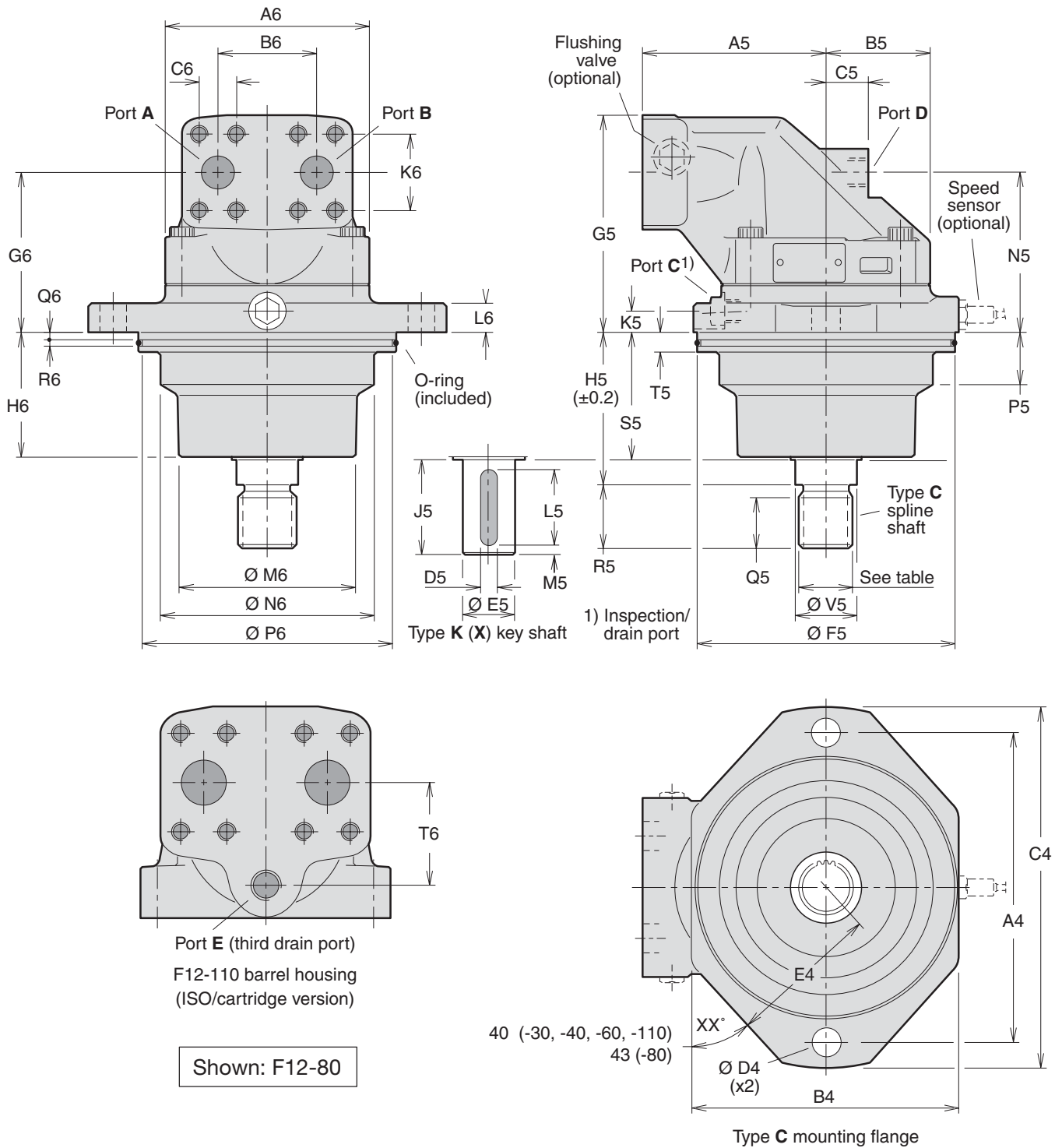

Dim.	F12-30	F12-40	F12-60	F12-80	F12-110	Ports	F12-30	F12-40	F12-60	F12-80	F12-110
A4	6.30	7.87	7.87	8.82	9.84	A, B size	3/4"	3/4"	3/4"	1"	1 1/4"
B4	5.51	6.46	6.46	7.72	8.11	Screw thread <sup>3)</sup>	M10 (0.79)	M10 (0.79)	M10 (0.79)	M12 (0.87)	M14 (1.02)
C4	7.40	9.25	9.25	10.24	11.26	C thread <sup>4)</sup>	M14 x1.5	M14 x1.5	M14 x1.5	M14 x1.5	M14 x1.5
D4	0.55	0.71	0.71	0.87	0.87	D, E thread <sup>4)</sup>	M18 x1.5	M18 x1.5	M22 x1.5	M22 x1.5	M22 x1.5
E4	3.03	3.74	3.74	4.33	4.57						
A5	3.94	4.33	4.92	5.31	5.71						
B5	2.32	2.56	2.76	3.05	3.35						
C5	0.98	1.02	0.87	1.26	1.50						
D5	0.31	1) 2)	0.39	0.47	0.55						
E5	1.1817/ 1.1812	1) 2)	1.3787/ 1.3780	1.5755/ 1.5749	1.7724/ 1.7717						
F5	5.3150/ 5.3125	6.2992/ 6.2967	6.2992/ 6.2967	7.4803/ 7.4775	7.8740/ 7.8712						
G5	5.00	5.24	5.75	6.18	6.89						
H5	3.50	3.63	3.63	4.35	4.83						
J5	1.97	2.36	2.36	2.76	-						
K5	0.55	0.63	0.59	0.59	0.59						
L5	1.57	1.97	1.97	2.20	-						
M5	0.20	0.20	0.20	0.28	-						
N5	3.58	3.82	4.33	4.49	4.84						
P5	0.87	1.18	1.22	1.57	1.57						
Q5	1.10	1.10	1.10	1.46	1.46						
R5	1.38	1.38	1.38	1.77	1.77						
S5	2.78	2.83	2.99	3.58	3.77						
T5	0.59	0.59	0.59	0.59	0.59						
V5	1.30	1.38	1.38	1.77	1.77						
A6	4.80	5.28	5.67	6.10	6.69						
B6	2.60	2.60	2.60	2.95	3.27						
C6	0.937	0.937	0.937	1.094	1.250						
G6	3.60	3.82	4.33	4.49	4.84						
H6	2.74	2.80	2.91	3.52	3.69						
K6	2.000	2.000	2.000	2.250	2.626						
L6	0.63	0.71	0.71	0.79	0.79						
M6	3.62	4.53	4.53	5.12	5.51						
N6	4.33	5.00	5.31	6.06	6.30						
P6	5.047	6.031	6.031	7.213	7.606						
Q6	0.20	0.20	0.20	0.20	0.20						
R6	0.20	0.20	0.20	0.20	0.20						
T6	-	-	-	-	2.68						

A, B: ISO 6162      3) Metric thread (depth in inches)  
4) Metric thread x pitch in mm.

**Spline shaft (DIN 5480; in mm)**  
Type C (standard)

F12-30	W30x2x14x9g
-40	W30x2x14x9g
-60	W30x2x14x9g
-80	W40x2x18x9g
-110	W40x2x18x9g

**Metric key shaft (in mm)**  
Type K (std)    Type X (opt.)

F12-30	30 dia.	-
-40	-	35 dia.
-60	35 dia.	-
-80	40 dia.	-
-110	-	-

**O-ring dimensions (in mm)**

F12-30	127x4
-40	150x4
-60	150x4
-80	180x4
-110	190x4

1) Key shaft type K: D5 - 0.31; E5 - 1.1817/1.1812  
2) Key shaft type X: D5 - 0.39; E5 - 1.3787/1.3780

**F12-30, -40, -60, -80 and -110**  
 (SAE versions with 4 bolt flange)

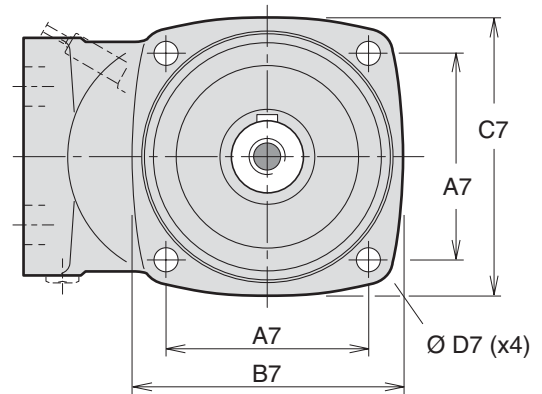
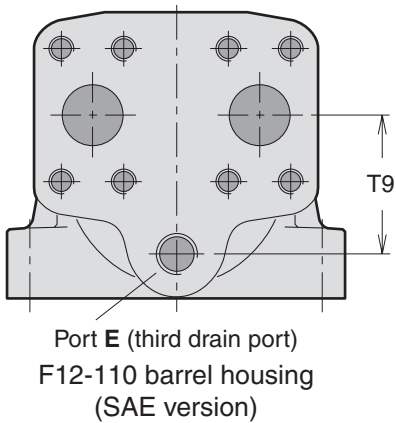
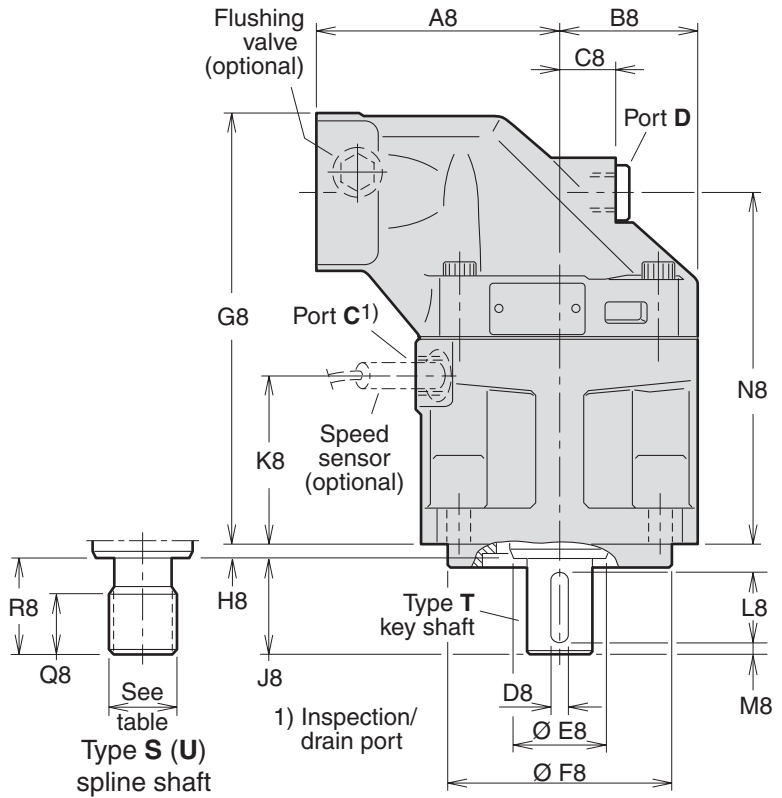
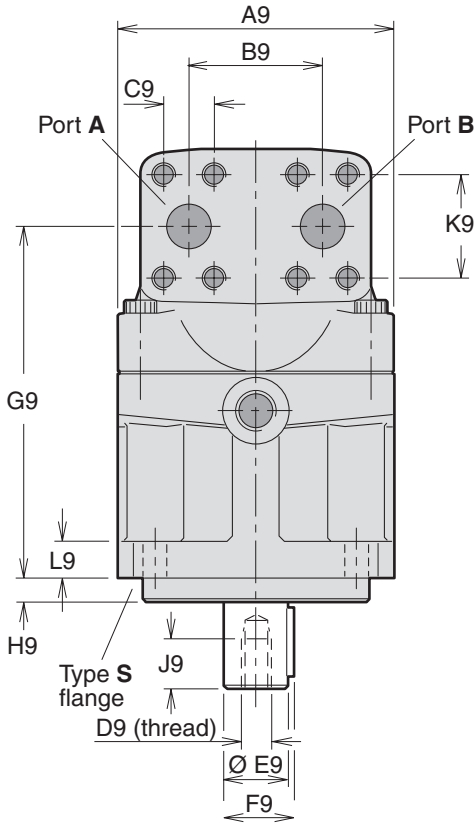

Shown: F12-80 with 4 bolt flange

Type S (SAE 4 bolt) mounting flange

Dim.	F12-30	F12-40	F12-60	F12-80	F12-110
A7	3.54	4.51	4.51	4.51	6.36
B7	4.65	5.83	5.83	6.10	8.03
C7	4.65	5.67	5.67	6.10	7.87
D7	0.55	0.55	0.55	0.55	0.83
A8	3.94	4.33	4.92	5.31	5.71
B8	2.32	2.56	2.76	3.05	3.35
C8	0.98	1.02	0.87	1.26	1.50
D8	0.25	0.31	0.31	0.38	0.44
E8	1.30	1.65	1.65	2.05	2.26
F8	4.000/ 3.998	5.000/ 4.998	5.000/ 4.998	5.000/ 4.998	6.000/ 5.998
G8	7.46	7.76	8.43	9.45	10.39
H8	0.31	0.31	0.31	0.31	0.31
J8	1.50	1.89	1.89	2.13	2.64
K8	2.83	2.99	3.11	3.74	3.90
L8	1.25	1.50	1.50	1.75	2.13
M8	0.10	0.16	0.16	0.16	0.29
N8	6.04	6.34	7.02	7.76	8.35
Q8 <sup>1)</sup>	0.91	0.91	0.91	0.98	1.34
Q8 <sup>2)</sup>	-	-	-	0.91	-
R8 <sup>1)</sup>	1.30	1.89	1.89	2.13	2.63
R8 <sup>2)</sup>	-	-	-	1.88	-
A9	4.80	5.28	5.67	6.10	6.69
B9	2.60	2.60	2.60	2.95	3.27
C9	0.937	0.937	0.937	1.094	1.250
D9*	5/16"-24	3/8"-24	3/8"-24	1/2"-20	5/8"-18
E9	1.000/ 0.998	1.250/ 1.248	1.250/ 1.248	1.500/ 1.498	1.750/ 1.748
F9	1.11	1.39	1.39	1.67	1.94
G9	6.06	6.34	7.02	7.76	8.35
H9	0.38	0.50	0.50	0.50	0.50
J9	0.63	0.75	0.75	1.02	1.26
K9	2.000	2.000	2.000	2.250	2.626
L9	0.71	0.79	0.79	0.79	0.87
T9	-	-	-	-	2.68

\* UNF-2B thread

- 1) Spline shaft type **S**
- 2) " " " " **U**

**Main ports A and B, type U (optional)**

F12-110	1 5/8" - 12 UN
---------	----------------

O-ring ports according to SAE J514d

Ports	F12-30	F12-40	F12-60	F12-80	F12-110
A, B size	3/4"	3/4"	3/4"	1"	1 1/4"
Screw thread <sup>3)</sup>	3/8"-16 (0.87)	3/8"-16 (0.79)	3/8"-16 (0.87)	7/16"-14 (1.06)	1/2"-13 (0.98)
C thread	7/8"-14	7/8"-14	7/8"-14	7/8"-14	1 1/16"-12
D thread	3/4"-16	3/4"-16	7/8"-14	7/8"-14	1 1/16"-12
E thread	-	-	-	-	1 1/16"-12

A, B: ISO 6162; C, D, E: O-ring boss (SAE J514)

3) UN thread (depth in inches)

**Mounting flange (SAE J744)**

	<b>S (standard)</b>	<b>X (optional)</b>
F12-30	SAE 'B', 4 bolt	-
-40	SAE 'C', "	-
-60	SAE 'C', "	-
-80	SAE 'C', "	SAE 'D', 4 bolt
-110	SAE 'D', "	-

**Spline shaft (SAE J498b, class 1, flat root, side fit)**

	<b>S (standard)</b>	<b>U (opt.)</b>	<b>X (optional)</b>
F12-30	SAE 'B' 13T, 16/32 DP	-	-
-40	SAE 'C' 14T, 12/24 DP	-	-
-60	SAE 'C' 14T, 12/24 DP	-	-
-80	SAE 'C-C' 17T, 12/24 DP	SAE 'C' 14T, 12/24 DP	SAE 'D' 13T, 8/16 DP
-110	SAE 'D' 13T, 8/16 DP	-	-

= Max 5100 psi (350 bar) operating pressure.

**Key shaft (SAE J744)**

	<b>T (standard)</b>	<b>X (optional)</b>
F12-30	SAE 'B-B' (1"/25.4 mm)	-
-40	SAE 'C' (1 1/4"/31.75 mm)	-
-60	SAE 'C' (1 1/4"/31.75 mm)	-
-80	SAE 'C-C' (1 1/2"/38.1 mm)	SAE 'D' (1 3/4"/44.45 mm)
-110	SAE 'D' (1 3/4"/44.45 mm)	-

**F12-30, -40, and -60**

(SAE versions with 2 bolt flange)

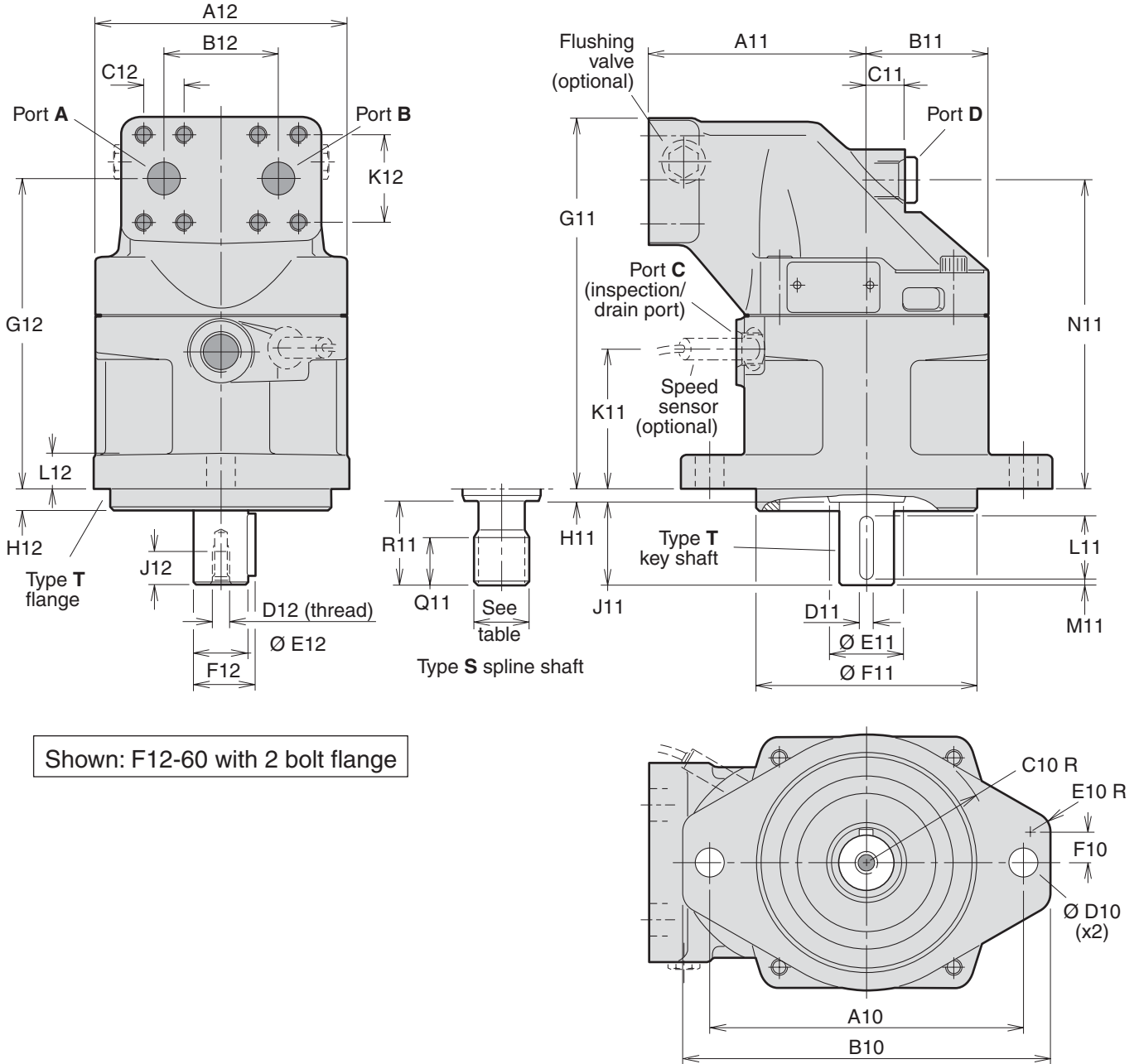

Shown: F12-60 with 2 bolt flange

Dim.	F12-30	F12-40	F12-60
A10	5.75	7.13	7.13
B10	6.93	8.46	8.46
C10	2.48	2.91	2.91
D10	0.57	0.69	0.69
E10	0.39	0.63	0.63
F10	0.39	0.61	0.61
A11	3.94	4.33	4.92
B11	2.32	2.56	2.76
C11	0.98	1.02	0.87
D11	0.25	0.31	0.31
E11	1.30	1.65	1.65
F11	4.000/ 3.998	5.000/ 4.998	5.000/ 4.998
G11	7.46	7.76	8.43
H11	0.31	0.31	0.31
J11	1.50	1.89	1.89
K11	2.80	3.03	3.21
L11	1.25	1.50	1.50
M11	0.10	0.16	0.16
N11	6.06	6.34	7.03
Q11	1.02	1.06	1.06
R11	1.30	1.89	1.89
A12	4.80	5.28	5.67
B12	2.60	2.60	2.60
C12	0.937	0.937	0.937
D12*	5/16"-24	3/8"-24	3/8"-24
E12	1.000/ 0.998	1.250/ 1.248	1.250/ 1.248
F12	1.11	1.39	1.39
G12	6.06	6.34	7.03
H12	0.38	0.50	0.50
J12	0.63	0.75	0.75
K12	2.000	2.000	2.000
L12	0.71	0.79	0.79

\* UNF-2B thread

Ports	F12-30	F12-40	F12-60
A, B size	3/4"	3/4"	3/4"
Screw thread <sup>1)</sup>	3/8"-16 (0.87)	3/8"-16 (0.79)	3/8"-16 (0.87)
C thread	3/4"-16	3/4"-16	7/8"-14
D thread	3/4"-16	3/4"-16	7/8"-14

A, B (main ports): SAE J518c (6000 psi)  
C, D (drain ports): O-ring boss (SAE J514)

1) UN thread (depth in inches).

**Main ports A and B, type U (optional)**

F12-30	1 1/16" - 12 UN
-40	1 5/16" - 12 UN
-60	1 5/16" - 12 UN

O-ring ports according to SAE J514d

 = Max 350 bar operating pressure.

**Mounting flange (SAE J744)**

**Type T**

F12-30	SAE 'B', 2 bolt
-40	SAE 'C', 2 bolt
-60	SAE 'C', 2 bolt

**Spline shaft (SAE J498b, class 1, flat root, side fit)**

**Type S**

F12-30	SAE 'B' 13 T; 16/32 DP
-40	SAE 'C' 14 T; 12/24 DP
-60	SAE 'C' 14 T; 12/24 DP

**Key shaft (SAE J744)**

**Type T**

F12-30	1" dia. SAE 'B-B'
-40	1 1/4" dia. SAE 'C'
-60	1 1/4" dia. SAE 'C'

**F11-150**

(CETOP version)

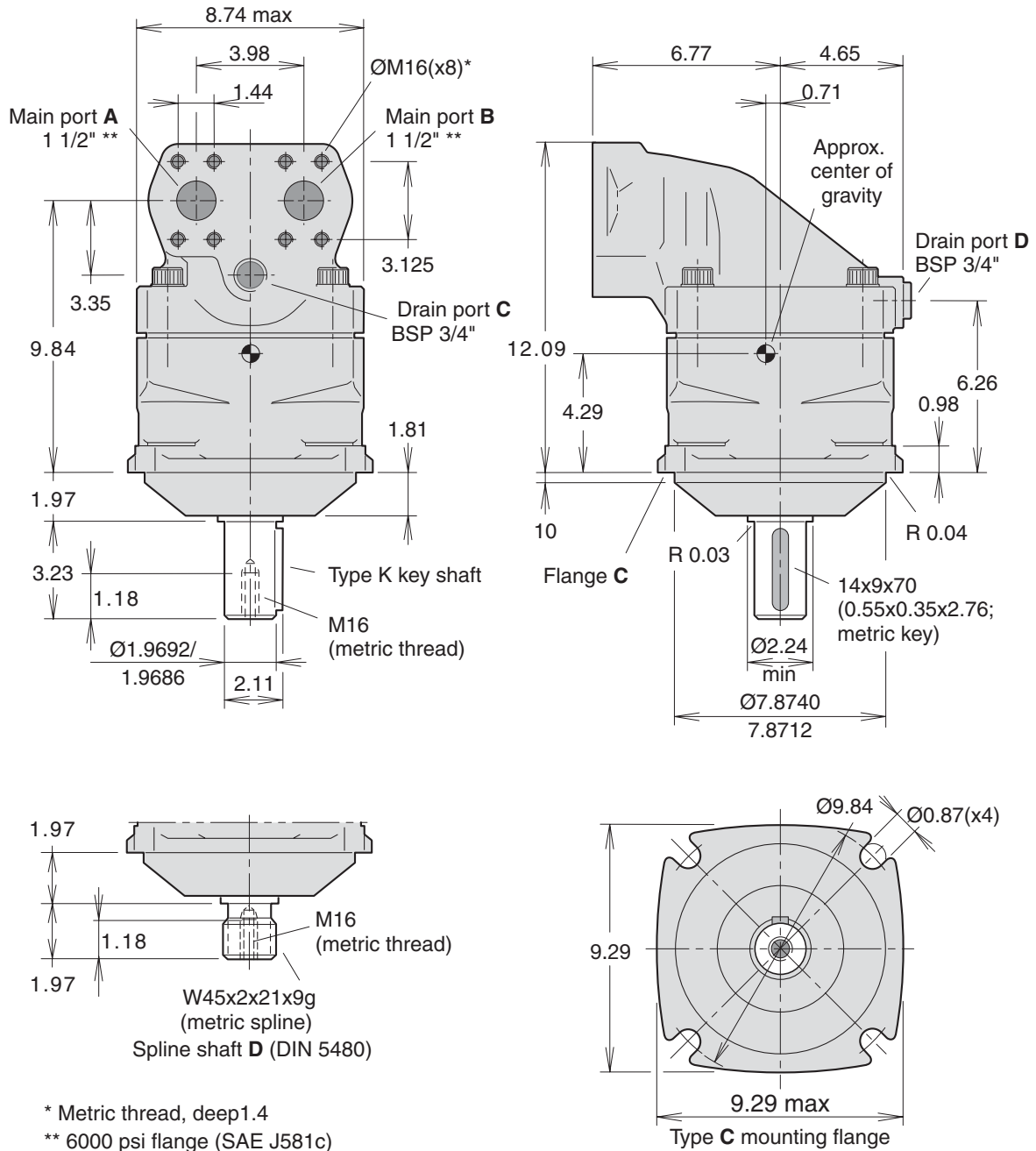



**F11-150**  
 (SAE version)

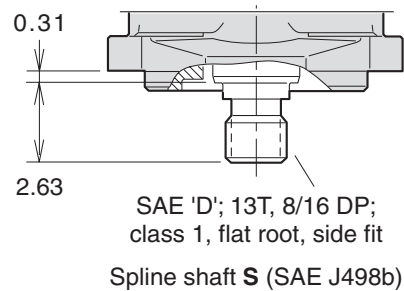
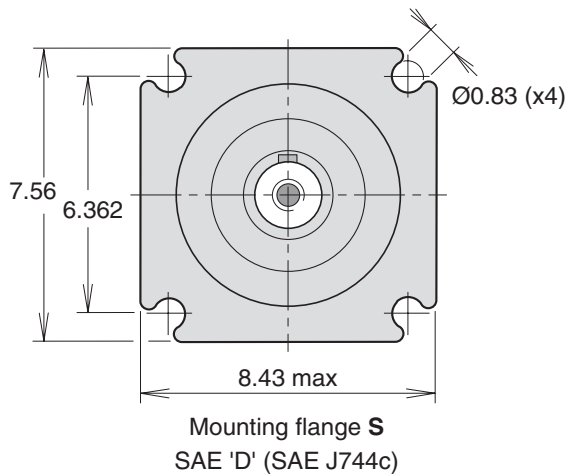
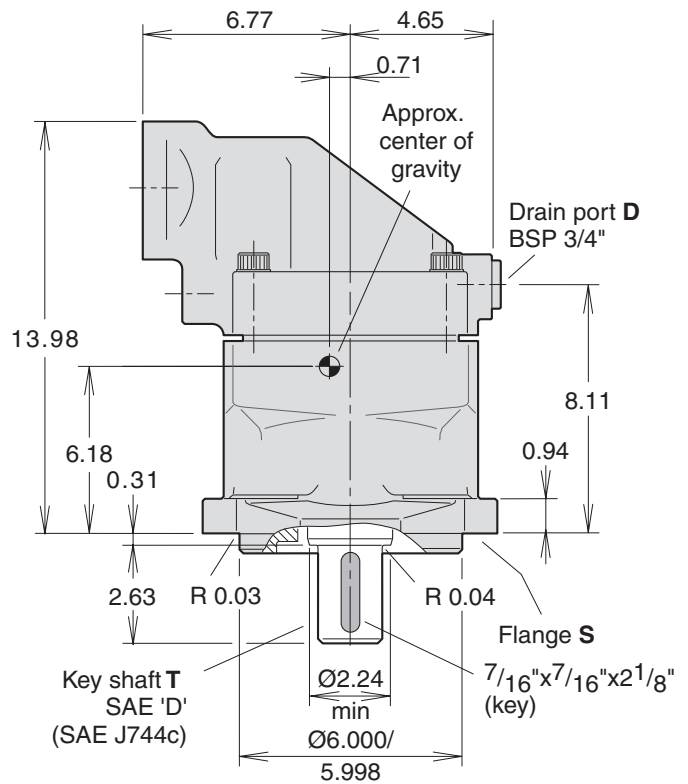
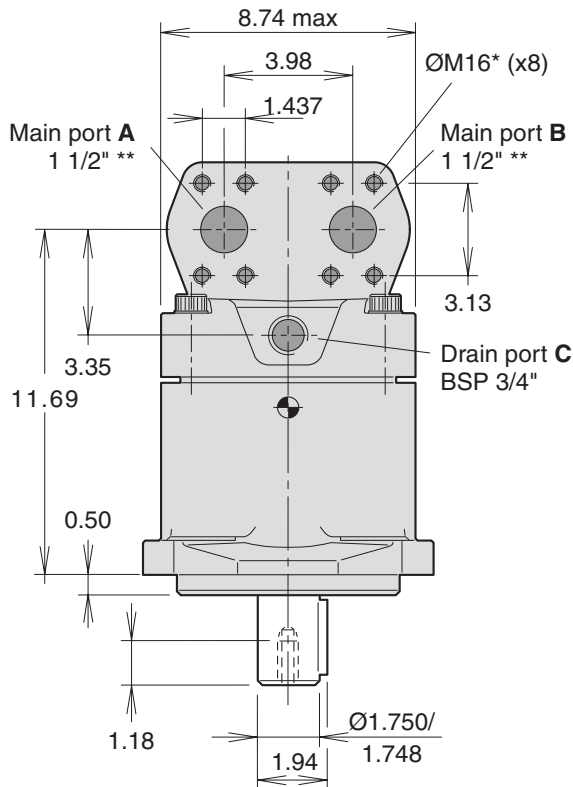

\* Metric thread, deep 1.4  
 \*\* 6000 psi flange (SAE J581c)

**F11-250**  
 (SAE version)

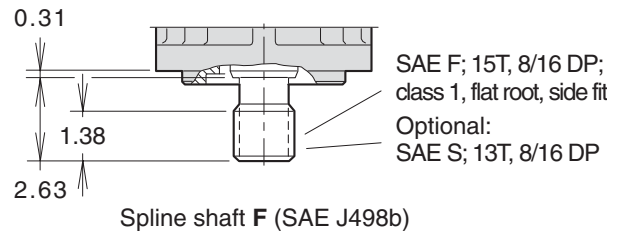
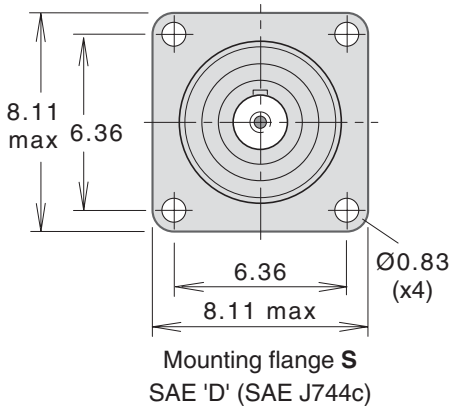
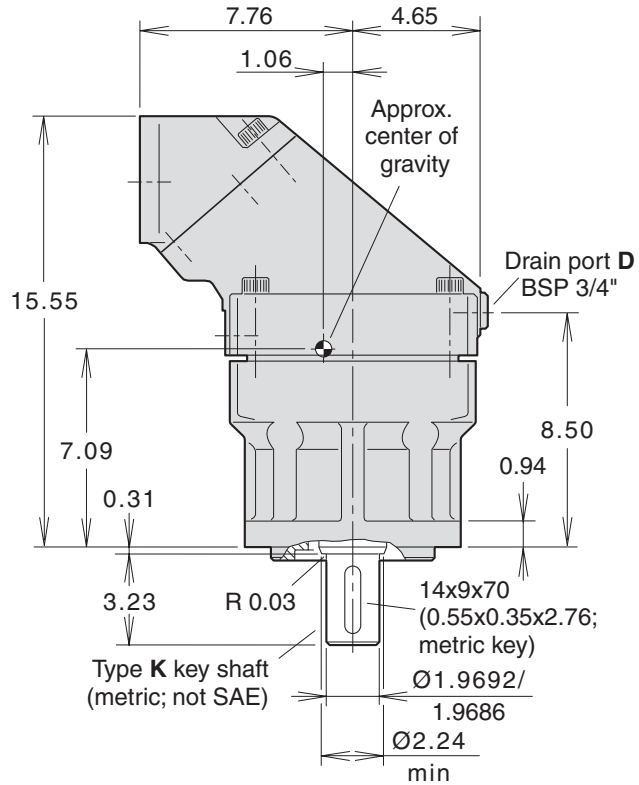
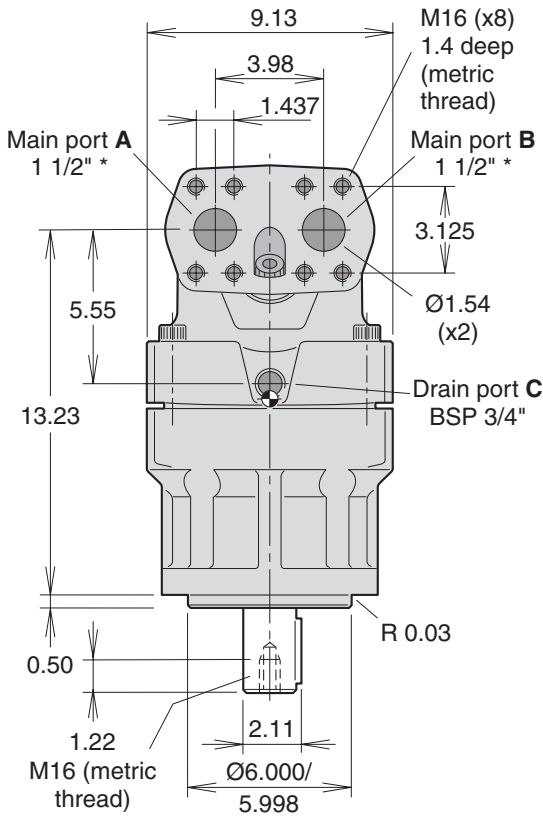

\* 6000 psi flange (SAE J581c)

**F11 saw motors**

Series F11 motors have proven extremely reliable in demanding applications such as bar (chain) saws. Primarily due to the 40° bent-axis design, spherical pistons (with laminated piston rings) and gear synchronization, very high speeds are permissible. Not even low temperatures at start-up affect reliability.

To further enhance the saw function and, at the same time, reduce weight, cost and installation dimensions, a specific saw motor has been developed (frame sizes -10, -14 and -19; refer to the illustration to the right) which is specifically dedicated to bar saws. The motor allows the saw bar bearings to be mounted directly on the motor housing, and the spur gear installs on the motor shaft without any additional bearings.

For more detailed information (available versions, ordering codes, installation dimensions, etc.), refer to 'F11 Saw Motors' (catalogue 9129 8245-02).

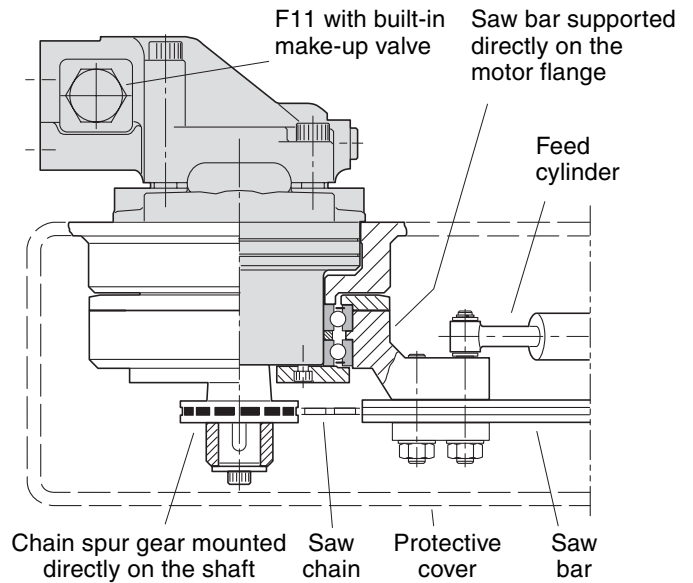

*Chain saw installation (example; F11-10 shown)*

**F11 fan motors**

Frame sizes -10, -14 and -19 are also available as 'fan motors' with a built-in check valve (refer to the schematic below) and CETOP mounting flange. Just like the saw motor, the fan motor can be operated at very high speeds without reliability problems. The fan is usually installed directly on the motor shaft without additional bearing support.

Additional information (available versions, ordering codes, installation dimensions, etc.) is available in publication 'F11 Fan Motors' (catalogue 9129 8247-02).

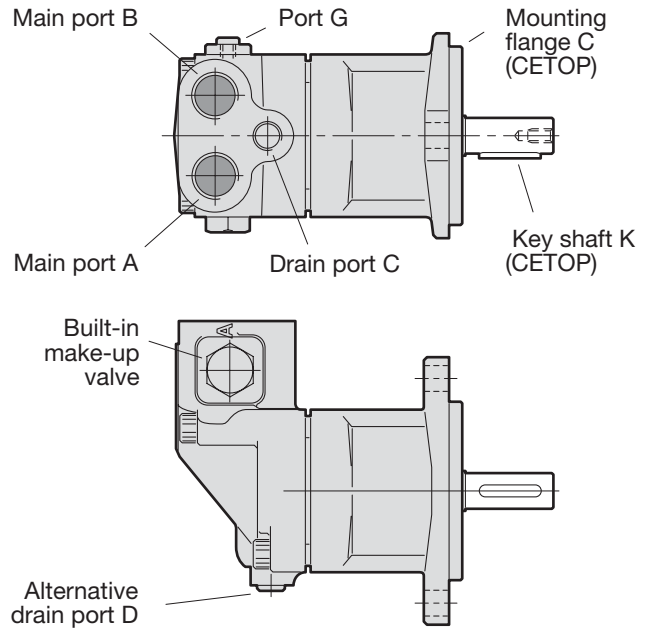

*Fan motor (F11-10 shown).*

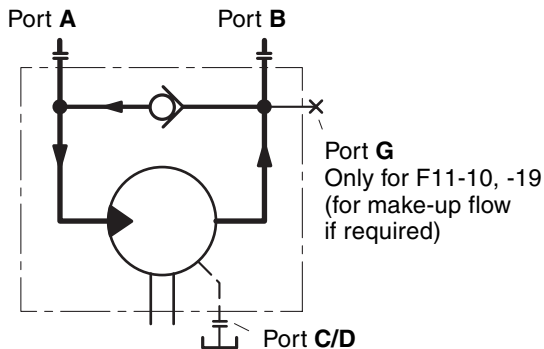

*Fan motor schematic (left hand rotation shown).*

**F12 integrated flushing valve**

(F12-30, -40, -60 and -80)

Series F12 (except F12-110; refer to the FV13 flushing valve block below) is available with an integrated flushing valve which provides the rotating parts with an additional cooling flow, required when operating at high speeds and power levels.

In a hydrostatic transmission, the valve also ensures that part of the main circuit fluid is being removed and replaced by cool, filtered fluid from the charge pump.

The flow is limited by a suitably sized nozzle that installes below a plug in the motor port flange.

**NOTE:** Ordering code, available nozzles and other information is provided in publication 'Mobile motor/pump accessories' (catalogue HY17-8258/UK).

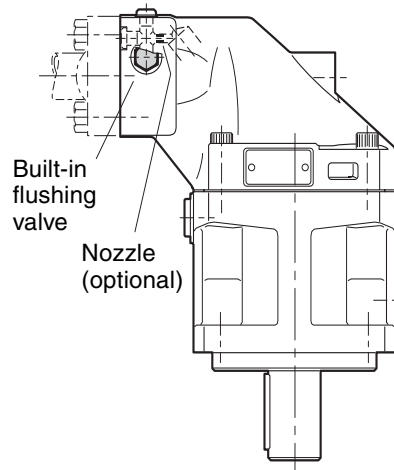

Integrated flushing valve (F12-30, -40, -60, -80)      Nozzle (optional)

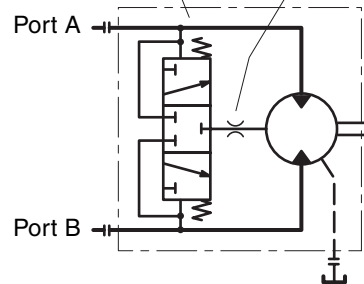

**F12 accessory valve blocks**

**Type FV13 flushing valve (for F12-110)**

A separate flushing valve block is available for the F12-110. It has the same function as the integrated valve for the other F12 frame sizes (above).

The valve block mounts between the motor port flange and the split flanges as shown to the right.

An optional nozzle can be installed in the valve block drain port.

Ordering code: FV13

**NOTE:** Additional information is available in publication 'Mobile motor/pump accessories' (catalogue HY17-8258/UK).

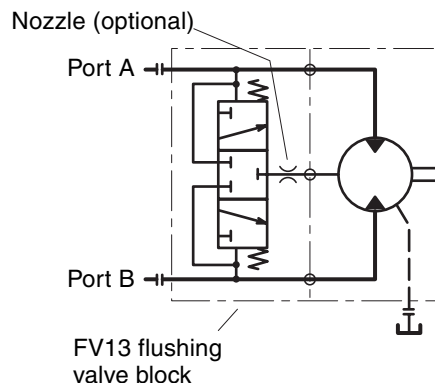
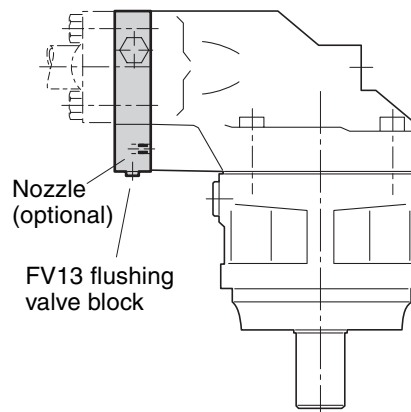

**Type BT brake valve**

When a motor (in an open loop system) is used in a hydrostatic vehicle transmission, the motor may operate faster than what corresponds to the available pump flow (e.g. in a steep downhill); this can lead to motor cavitation and loss of braking power.

The BT brake valve prevents cavitation by throttling the return flow from the motor as soon as the pressure level in the inlet port decreases to approximately 35 bar. At the same time, motor braking is provided when the pump flow decreases or is shut off.

The BT brake valve can be supplied with various optional functions such as a mechanical brake release valve and a flushing valve.

The valve block is very compact and installs between the motor port flange and the split flanges (refer to the illustration).

The BT valve block is available in two sizes:

- BT21 (3/4") for F12-30, -40, -60
- BT22 (1") for F12-80

**NOTE:** Detailed information on the BT valve is provided in publication 'Mobile motor/pump accessories' (catalogue HY17-8258/UK).

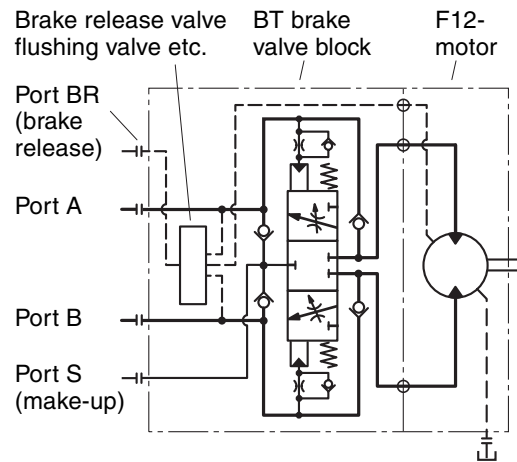
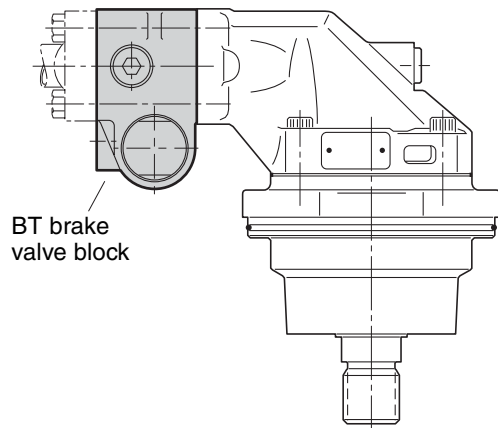

**Type SR pressure relief/make-up valve**

The SR pressure relief/make-up valve block for series F12 motors is designed to protect the motor from high pressure spikes as well as provide an excellent make-up function to help prevent motor cavitation (when port G is pressurized).

The valve block mounts between the motor port flange and the split flanges (as shown to the right).

The SR block is available in three sizes:

- SR11 (3/4") for F12-30, -40, -60
- SR12 (1") for F12-80
- SR13 (1 1/4") for F12-110

**NOTE:**

- For additional information such as pressure settings and installation dimensions, refer to publication 'Mobile motor/pump accessories' (catalogue HY17-8258/UK).
- To obtain a combined cross-over relief/make-up and flushing function on the F12-110, the SR13 and FV13 valve blocks can be stacked (with the flushing valve block mounted next to the motor).

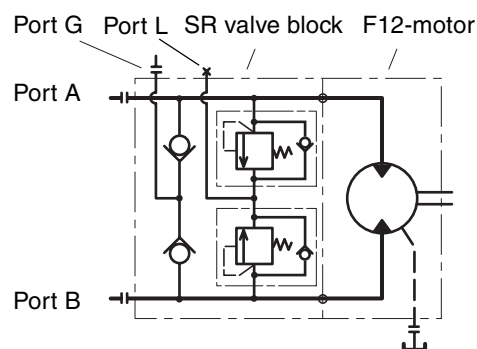
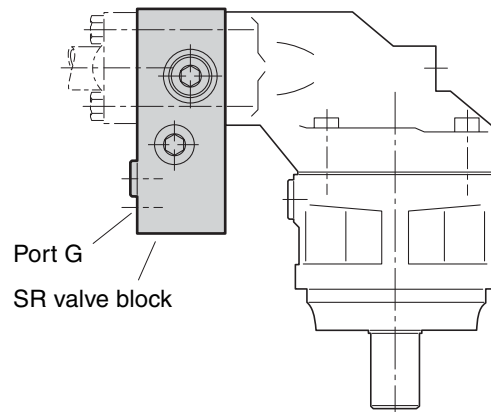

### Type SV pressure relief valve

The SV pressure relief valve for series F12 motors protects the motor and the corresponding main hydraulic lines from pressure spikes. Like the SR valve block (page 31), it has integrated cartridge type pressure relief valves and mounts between the motor port flange and the split flanges as shown to the right.

The design of the relief valves permits a limited make-up flow (when port L is pressurized).

The SV valve block is available in three sizes:

- SV11 (3/4") for F12-30, -40, -60
- SV12 (1") for F12-80
- SV13 (1 1/4") for F12-110

**NOTE:** - Detailed information on available pressure settings, installation dimensions, etc. is provided in publication 'Mobile motor/pump accessories' (catalogue HY17-8258/UK).

- On the F12-110, the FV13 flushing valve block (page 36) can be mounted between the SV13 block and the motor port flange to obtain a combined pressure relief and flushing function.

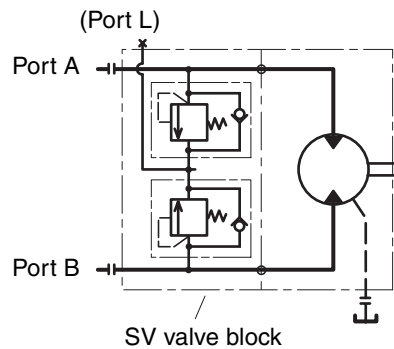
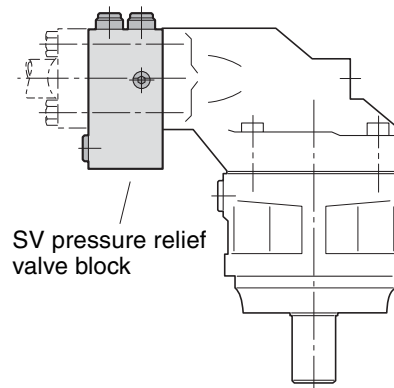

### Speed sensor

A speed sensor kit is available for series F11/F12. A ferromagnetic differential (Hall-effect) sensor installs in a separate, threaded hole in the F11/F12 bearing housing.

On F12 the speed sensor is directed towards the ring gear. On F11 the speed sensor is directed towards the pistons. The speed sensor outputs a square wave signal within a frequency range of 5 Hz to 20 kHz.

**NOTE:** - The motor bearing housing must be prepared for the speed pick-up; refer to the F11/F12 ordering codes (pages 7-12).

- On F11 **the pistons position must be known before mounting.**
- Additional information is provided in 'Mobile motor/pump accessories' (catalogue HY17-8258/UK).
- The speed sensor is also shown in the illustrations on pages 19, 21, 22, 24, 26 and 28.

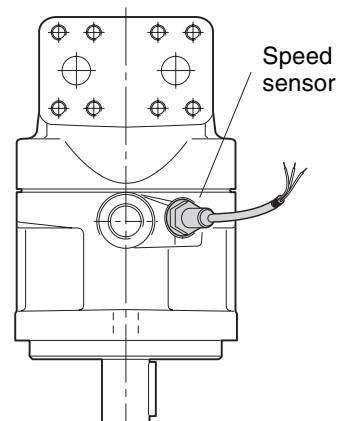

*F12 with speed sensor.*

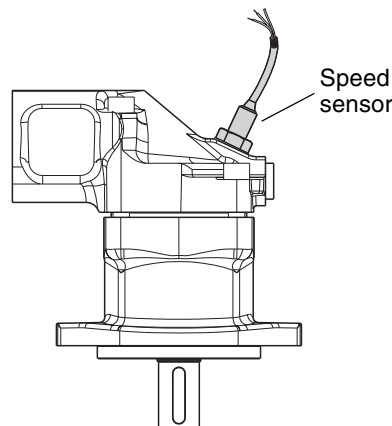

*F11-14 with speed sensor.*

### F12 main port suction fittings

#### Suction fittings

To minimize the risk for cavitation when operating the F12 as a pump, we recommend using our suction fittings; all take 2" hoses.

Part no.	SAE size	For	L [inch]
379 4070	3/4"	F12-30	3.94
		F12-40	
		F12-60	
370 4095	1"	F12-80	3.94
370 3916	1 1/4"	F12-110	4.02

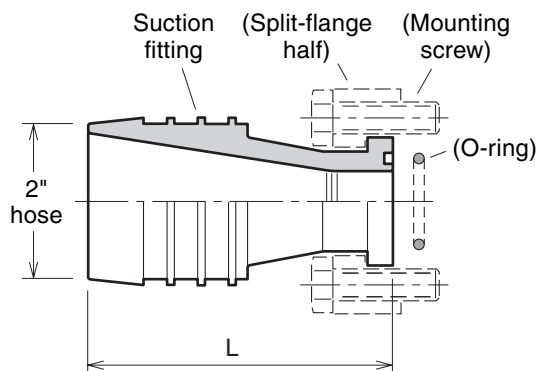

The suction fittings are designed for use with standard SAE or metric split-flange halves as shown. O-ring and mounting screw sizes are listed below.

SAE size	O-ring dimension [mm]	Screw size	
		SAE	Metric
3/4"	30.0x3.53	3/8"-16x1.50	M10x35
1"	32.9x3.53	7/16"-14x1.50	M12x40
1 1/4"	37.7x3.53	1/2"-13x1.75	M14x45

#### Suction fitting kits

Suction fitting kits are available for the F12 ISO and Cartridge versions. A kit consists of a suction fitting (shown above), two split-flange halves, an O-ring and four mounting screws.

Part no.	SAE size	For	Screw size
379 4421	3/4"	F12-30/-40/-60	M10x35
370 4098	1"	F12-80	M12x40
370 3926	1 1/4"	F12-110	M14x45

#### Split-flange kits

Separate metric split-flange kits, consisting of two split-flange halves and four mounting screws for use on the F12 ISO and cartridge versions, are also available.

Part no.	SAE size	For	Screw size
379 4405	3/4"	F12-30/-40/-60	M10x35
370 4329	1"	F12-80	M12x40
370 4330	1 1/4"	F12-110	M14x45

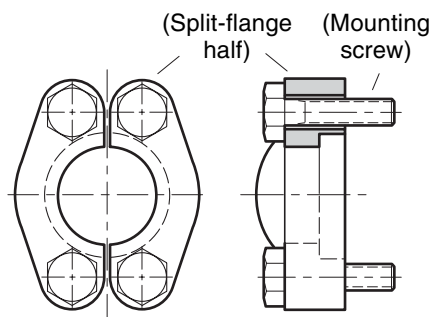

**Direction of rotation**

The M and H versions of series F11, and the M version of series F12, are bi-directional.

The L and R pump versions are uni-directional, allowing higher selfpriming speeds (refer to page 14).

The illustration to the right shows direction of flow versus shaft rotation. In a motor application, the shaft turns clockwise when port **B** (black arrow) is pressurized, and counter clockwise when port **A** (open arrow) is pressurized.

In a pump application where the shaft turns clock-wise, port B is the inlet port and should be connected to tank; when the shaft turns counter clockwise, port A is the inlet port.

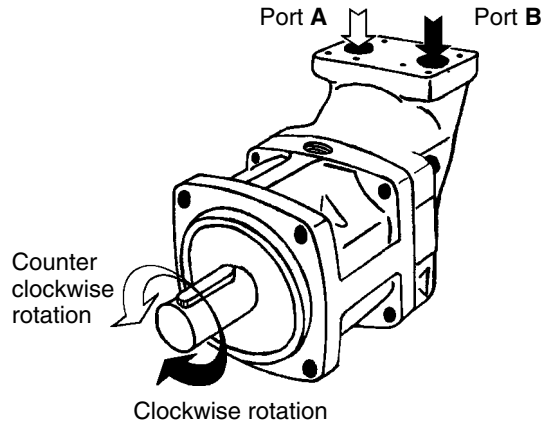

**NOTE:**

When operating the F11/F12 as a pump above the selfpriming speed (valid for both the pump and motor versions), the inlet must be sufficiently pressurized. Increased noise and deteriorating performance may otherwise be experienced.

For further information refer to 'Selfpriming speed and required inlet pressure' on page 6.

**Hydraulic fluids**

Ratings and performance data for series F11/F12 are based on operating with good quality, contamination-free, petroleum-based fluids.

Hydraulic fluids type HLP (DIN 51524), automatic transmission fluids type A, or API CD engine oils can be used.

Fire resistant fluids (when used under modified operating conditions) and synthetic fluids may also be suitable.

For additional information, refer to Hydraulic Marketing IS data base:

- Hydraulic fluid specifications
- Fire resistant fluids.

**Operating temperature**

The following temperatures should not be exceeded (type **H** and **N** shaft seals):

Drain fluid: 195 °F (90 °C)

Viton shaft seals (F11 type **E**, F12 type **V**) can be used to 240 °F (115 °C) drain fluid temperature.

**NOTE:** The temperature should be measured at the utilized drain port.

Continuous operation may require case flushing in order to meet the viscosity and temperature limitations.

The following table shows operating speeds, above which flushing is usually required, as well as suggested flow through the case.

**Series F11**

Frame size	Speed [rpm]	Flow [l/min]	Flow [gpm]
F11-5	5500	1-2	0.25-0.5
F11-10	4500	2-3	0.5-0.8
F11-14	4500	2-3	0.5-0.8
F11-19	4000	2-4	0.5-1.0
F11-150	2200	10-20	2.6-5.2
F11-250	1800	12-22	3.2-5.8

**Series F12**

Frame size	Speed [rpm]	Flow [l/min]	Flow [gpm]
F12-30	3500	4-8	1.0-2.1
F12-40	3000	5-10	1.3-2.6
F12-60	3000	7-14	1.9-3.7
F12-80	2500	8-16	2.1-4.2
F12-110	2300	9-18	2.4-4.8



**Viscosity**

The ideal operating range is 75 to 150 SUS (15 to 30 mm<sup>2</sup>/s).

At operating temperature, the viscosity (of the drain fluid) should be kept above 46 SUS (8 mm<sup>2</sup>/s [cSt]).

At start-up, the viscosity should not exceed 5 000 SUS (1000 mm<sup>2</sup>/s)

**Filtration**

To obtain the highest service life of the F11/F12, the fluid cleanliness should meet or exceed ISO code 18/13 (ISO 4406).

During normal operating conditions, a 10 µm (absolute) filter is recommended.

**Case pressure**

The tables below show the highest recommended case pressure as a function of shaft speed.

'Nominal' shaft seal life can be expected at a certain speed and the corresponding max case pressure. Seal life will be shorter, however, at unfavourable operating conditions (high temperature, low oil viscosity, contaminated oil).

**Series F11**

Max case pressure [psi] versus shaft speed [rpm]

Speed Shaft seal	1500		3000		4000		5000		6000		8000		9000		10000		11000		12000	
	H/V	N/E	H/V	N/E	H/V	N/E	H/V	N/E	H/V	N/E	H/V	N/E	H/V	N/E	H/V	N/E	H/V	N/E	H/V	N/E
F11-5	20	2.2	13	1.9	10	1.6	8	1.3	6.5	0.9	5	0.6	4.2	0.5	4	0.3	3.5	0.2	3	0
F11-10	20	2.2	11.5	1.8	8.5	1.2	7	1.0	5.5	0.7	4	0.5	3.8	0.4	3.5	0.2	3.0	0	-	-
F11-14	19	2.2	9.5	1.5	7	1.0	5.5	0.8	4.5	0.5	3.5	0.4	3.0	0.2	2.5	0	-	-	-	-
F11-19	19	2.2	9.5	1.4	7	0.9	5.5	0.6	4.5	0.4	3.5	0.3	3.0	0	-	-	-	-	-	-
F11-150	9.5	2.2	4.5	0.6	-	-	-	-	-	-	-	-	-	-	-	-	-	-	-	-
F11-250	9.5	-	4.5	-	-	-	-	-	-	-	-	-	-	-	-	-	-	-	-	-

Max recommended case pressure versus shaft speed - F11 seal types **H** or **V** and **N** or **E**.

**Series F12**

Max case pressure [psi] vs. shaft speed [rpm]

Speed Shaft seal	1500		3000		4000		5000		6000	
	H/V	N	H/V	N	H/V	N	H/V	N	H/V	N
F12-30	205	30	100	20	80	15	65	10	50	-
F12-40	175	30	85	15	65	10	50	5	-	-
F12-60	175	30	85	15	65	10	50	5	-	-
F12-80	145	30	70	10	60	5	-	-	-	-
F12-110	140	30	65	10	-	-	-	-	-	-

Max recommended case pressure versus shaft speed - F12 seal types **H** or **V**, and **N**

**Case drain connections**

Series F11/F12 have two drain ports, **C** and **D**, while F12-110 has an additional port, **E**.

The uppermost drain port (such as port C in the illustration below) should always be utilized.

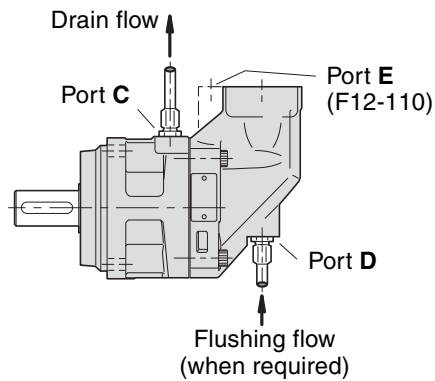

In mounting positions such as 'shaft up' (below) a spring loaded check valve should be installed in the drain line in order to insure a sufficiently high oil level in the case.

Preferably, the drain line should be connected directly to the reservoir.

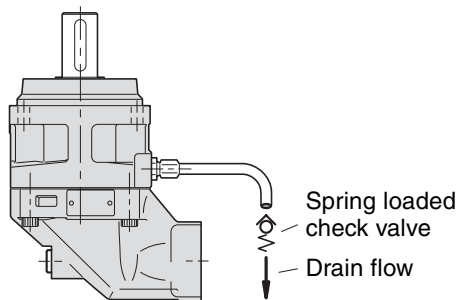
**Before start-up**

Make sure the F11/F12 case as well as the entire hydraulic system is filled with a recommended fluid.

The internal leakage, especially at low operating pressures, is *not* sufficient to provide lubrication at start-up.

**NOTE:**

- To avoid cavitation and obtain a low noise level as well as reduced heat generation, tubes, hoses and fittings must be adequately dimensioned.
- Preferably, the suction line flow speed should be 1.5 to 3.5 fps (0.5 to 1 m/s), and pressure line flow speeds 10 to 16 fps (3 to 5 m/s).
- For series F12, suitable suction fittings are available (refer to page 39).



## **WARNING**

**FAILURE OR IMPROPER SELECTION OR IMPROPER USE OF THE PRODUCTS AND/OR SYSTEMS DESCRIBED HEREIN OR RELATED ITEMS CAN CAUSE DEATH, PERSONAL INJURY AND PROPERTY DAMAGE.**

This document and other information from Parker Hannifin Corporation, its subsidiaries and authorized distributors provide product and/or system options for further investigation by users having technical expertise. It is important that you analyze all aspects of your application, including consequences of any failure, and review the information concerning the product or system in the current product catalogue. Due to the variety of operating conditions and applications for these products or systems, the user, through its own analysis and testing, is solely responsible for making the final selection of the products and systems and assuring that all performance, safety and warning requirements of the application are met.

The products described herein, including without limitation, product features, specifications, designs, availability and pricing, are subject to change by Parker Hannifin Corporation and its subsidiaries at any time without notice.

## **Offer of Sale**

Please contact your Parker representation for a detailed "Offer of Sale".

# Hydraulics Group Sales Offices

---

## **North America**

### **USA, Canada**

100 Parker Drive  
Otsego, MI 49078  
USA  
Tel: +1 269-694-9411  
Fax: +1 269-694-4638

### **Mexico**

Via de Ferrocarril a Matamoros #730  
Apodaca, N.L.  
Mexico  
C.P. 6 6 6 0 0  
Tel: +52 81 56 6000  
Fax: +52 81 56 6076

## **Latin America**

### **Pan American Division**

7400 N.W. 19th Street  
Suite A  
Miami, FL 33126  
USA  
Tel: +305 470 8800  
Fax: +305 470 8808

### **Argentina**

Stephenson 2711  
(1667) Tortuguitas–Malvinas Argentinas  
Pcia. de Buenos Aires  
Argentina  
Tel: +54 11 4752 4129  
Fax: +54 11 4752 3704

### **Brazil**

Av. Lucas Nogueira Garcez  
2181 Jacarei, SP Brazil 12300-000  
Brazil  
Tel: +55 12 354 5100  
Fax: +55 12 354 5262

### **Chile**

Av. Americo Vespucio 2760-C,  
Conchali  
Santiago  
Chile  
Tel: +56 2 623 1216  
Fax: +56 2 623 1421

### **Venezuela**

Av. Principal de Boleita Norte con Calle Miraima,  
Edf. Draza, Planta Baja  
Caracas 1070  
Venezuela  
Tel: +58 212 238-5422  
Fax: +58 212 239-2272

***Parker Hannifin is the world's premier supplier of motion and control systems and solutions, with sales and manufacturing facilities throughout the world. For product information and details of your nearest Parker sales office, visit us at [www.parker.com](http://www.parker.com) or call free on 1-800-272-7537 (North America).***



Catalogue HY17-8249/US  
2M 03/04 RT

© Copyright 2004  
Parker Hannifin Corporation  
All rights reserved.