

DETAILED TECHNICAL CATALOGUE

MONOBLOCK DIRECTIONAL  
CONTROL VALVES

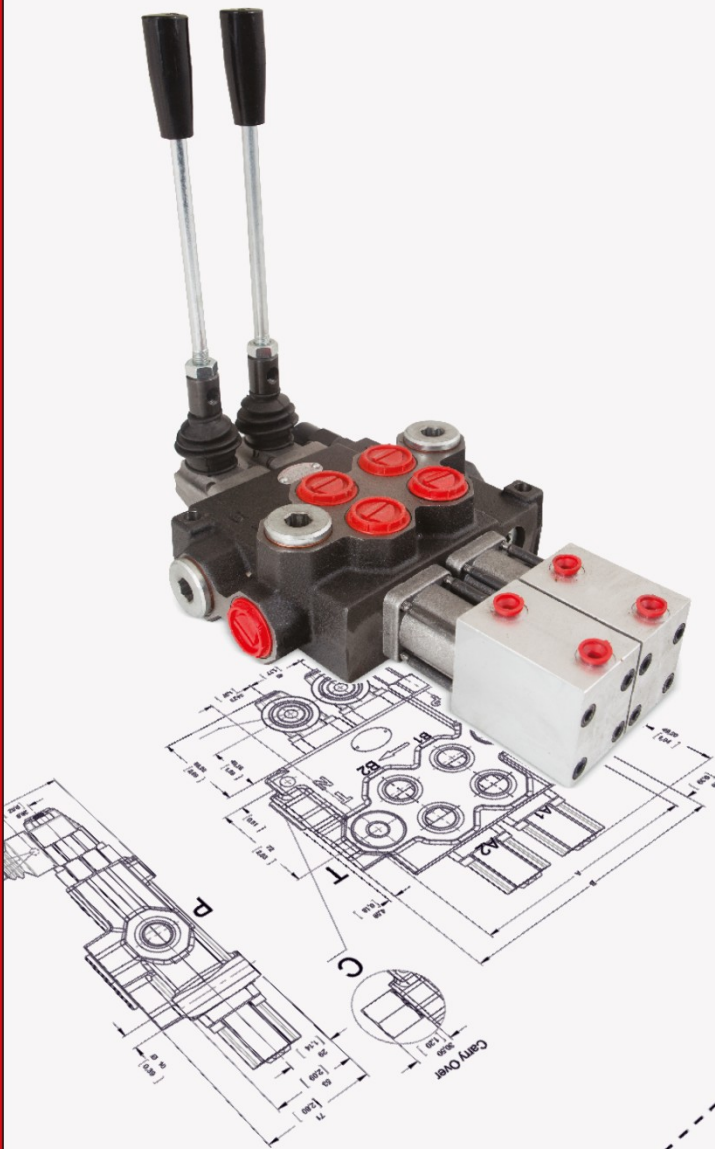

**GM-M70**

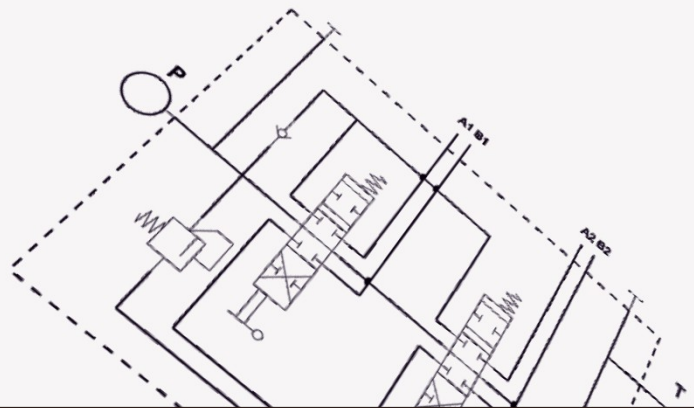

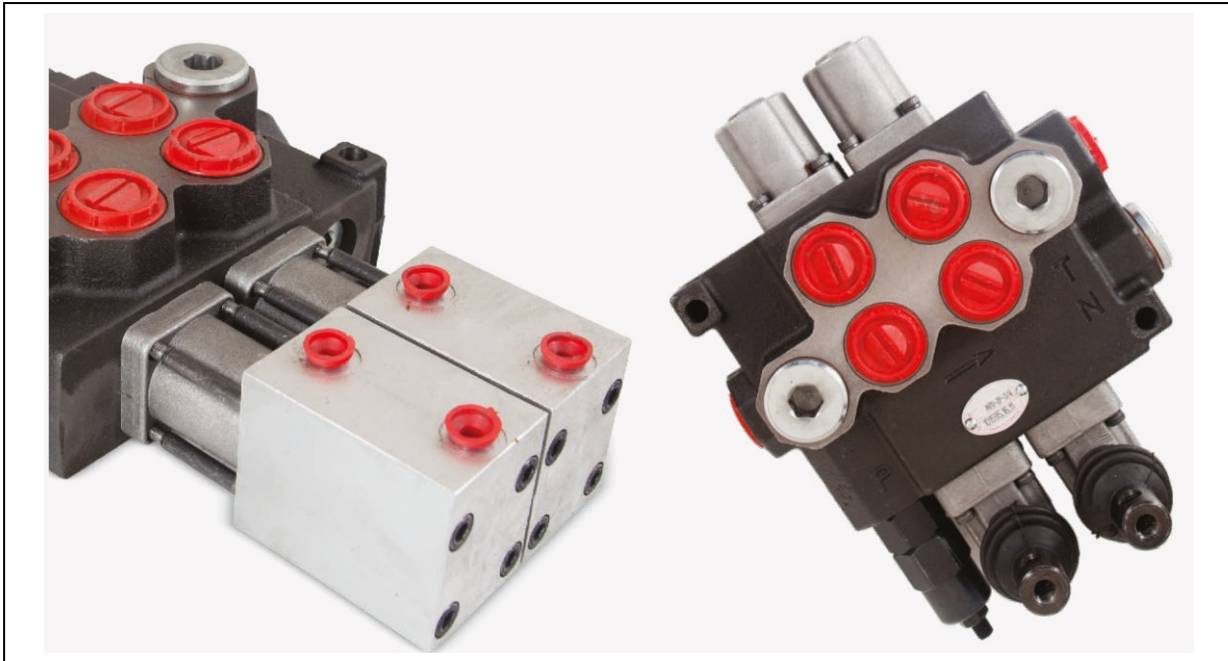

## Contents

<i>Working Conditions</i>	3
<i>Dimensional Data</i>	4
<i>Hydraulic Circuit</i>	5
<i>Performance Data And Curve</i>	6
<i>Inlet Relief Options</i>	7
<i>Ordering Codes</i>	8
<i>Spool Options</i>	10
<i>Spool Positioners – Side of Return</i>	13
<i>Spool Positioners – Side of Lever Control</i>	15
<i>Outlet Port Options</i>	16
<i>Installation and Maintenance</i>	18
<i>Technical Data</i>	19

## Additional Informations

**Note:** This catalog shows the product in the most standard configurations. For Other Configurations, more detailed information or special request, Please contact Customer Service Dpt.

**Warning!** :All specifications of this catalog refer to the standard product at this date (08/2011) . GEMMA, oriented to a continuous improvement, reserves the right to discontinue, modify or revise the specifications, without notice.

**GEMMA IS NOT RESPONSIBLE FOR ANY DAMAGE CAUSED BY AN INCORRECT USE OF THE PRODUCT.**

## Working Conditions

Nominal Flow Rating / Displacement	70 l/min	18 U.S.G.P.M
Maximum Working Pressure (Parallel Circuit)	315 Bar	4600 PSI
(Series Circuit)	250 Bar	3600 PSI
Max. Back Pressure	25 Bar	360 PSI
Oil Temperature with NBR Seals	-20 to 80 C°	-4 to 176 F°
with FPM (Viton) Seals	-20 to 100 C°	-4 to 212 F°
Oil Viskosity – Operating Range	From 10 to 75 mm2/s	From 10 to 75 cSt
Minumum / Maximum	10 / 400 mm2/s	10 / 400 cSt
Oil Filtration	≤30 μ	
Ambiant Temperature Range	-35 to 60 C°	-31 to 140 F°
Number Of Spools		1 to 6
Internal Leakage (at 100 bar (1450 PSI), 40C° (110 F°), 46 cSt – A(B)—T)	3 cm3/min	0,18 in3/min
Max. Level Of Contamination	19/16 - ISO 4406	

Not: This catalogue shows technical specifications measured with mineral oil of 46 mm2/s-46 cSt viscosity at 40 C° temparture.

## Features

- Simple, compact and heavy duty designed monoblock valves from 1 to 6 sections for open and closed center hydraulic systems.
- Fitted with a main pressure relief valve and a load check valve.
- Optionaly Carry-Over port only parallel circuit.
- Interchangeable spool diameter is 18 mm – 0,71 in.
- Available manual, pneumatic, hydraulic and electro-pneumatic spool control kits.

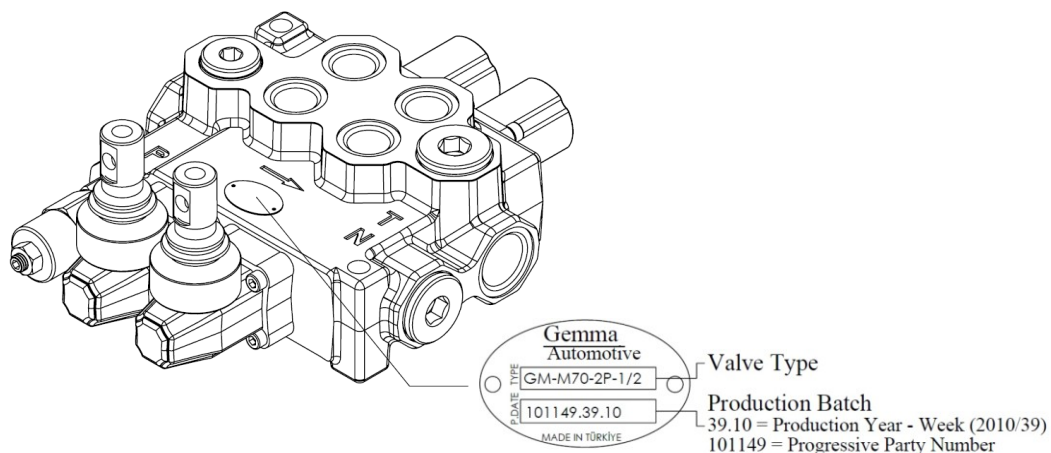

## Dimensional Data

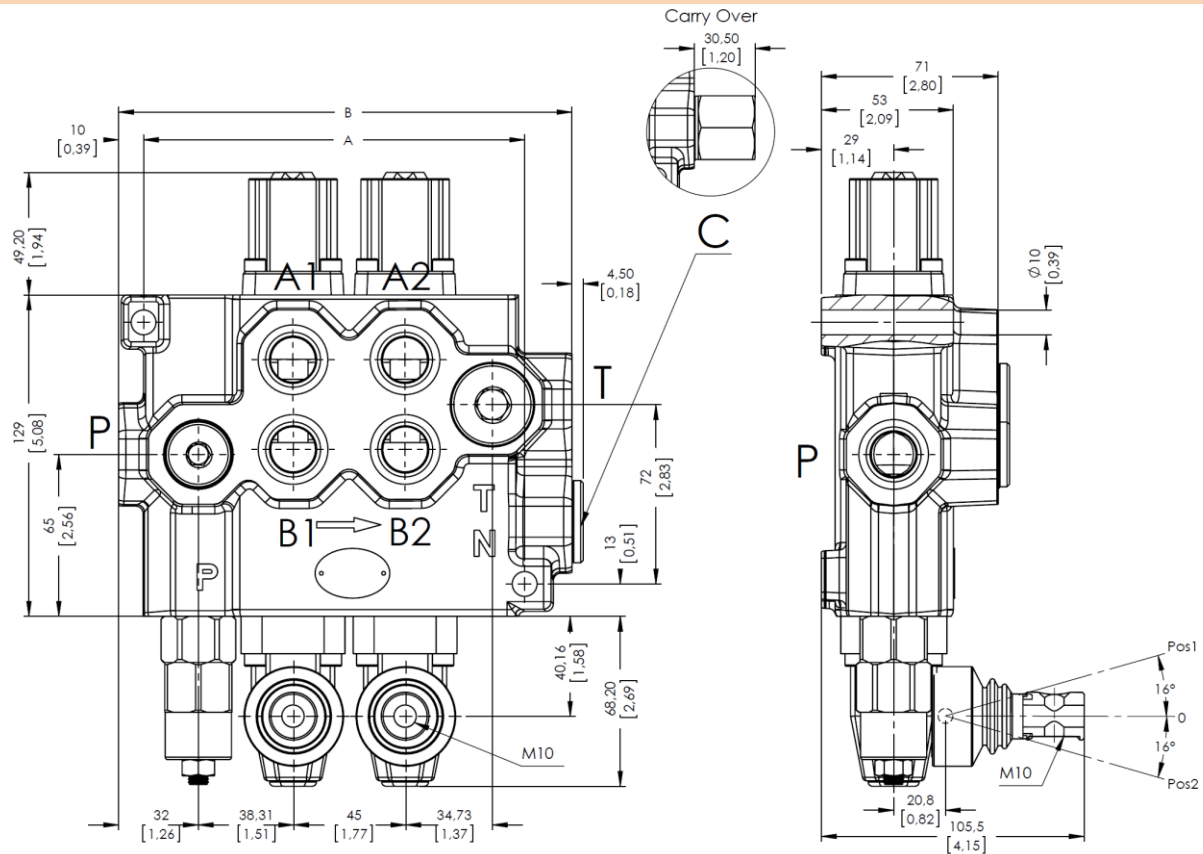

TYPE	A		B		Weight	
	mm	in	mm	in	Kg	lb
GM-M70-1P	108	4,25	137	5,40	5,65	12,45
GM-M70-2P	153	6,03	182	7,17	8,25	18,18
GM-M70-3P	198	7,80	227	8,94	10,85	23,92
GM-M70-4P	243	9,57	272	10,72	13,45	29,65
GM-M70-5P	288	11,35	317	12,49	16,05	35,38
GM-M70-6P	333	13,12	362	14,26	18,65	41,11

## Standard Threads

PORT	BSP (Iso 228)		UN-UNF (Iso 11926-1)	Metric (Iso 262)
	1/2" Series	3/4" Series		
<b>P</b> Inlet	G 1/2	G 3/4	1 1/16-12 UN	M27x2
<b>A-B</b> Ports	G 1/2	G 3/4	7/8-14 UNF	M22x1.5
<b>T</b> Outlet	G 3/4	G 3/4	1 1/16-12 UN	M27x2
Pneumatic	G 1/4	G 1/4	NPTF 1/8 - 27	NPTF 1/8 - 27
Carry-Over	G 3/4	G 3/4	1 1/16-12 UN	G 3/4

Hydraulic Circuit

Parallel - Standard Configurations With Side Inlet And Outlet Open Center

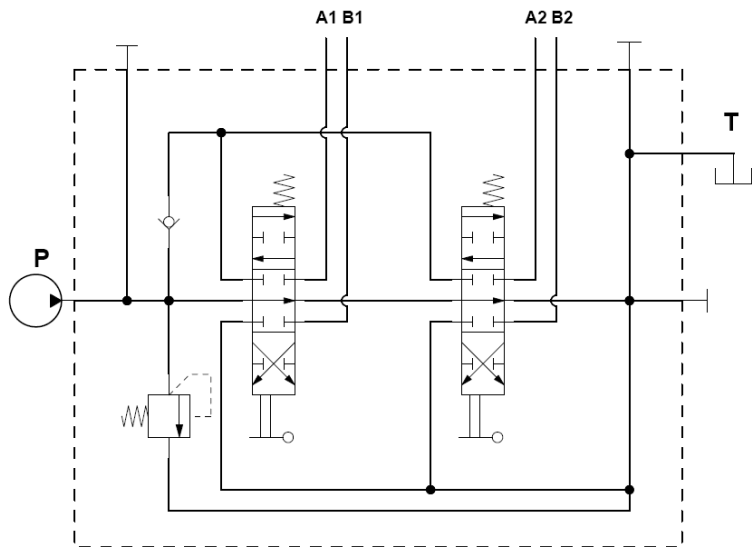
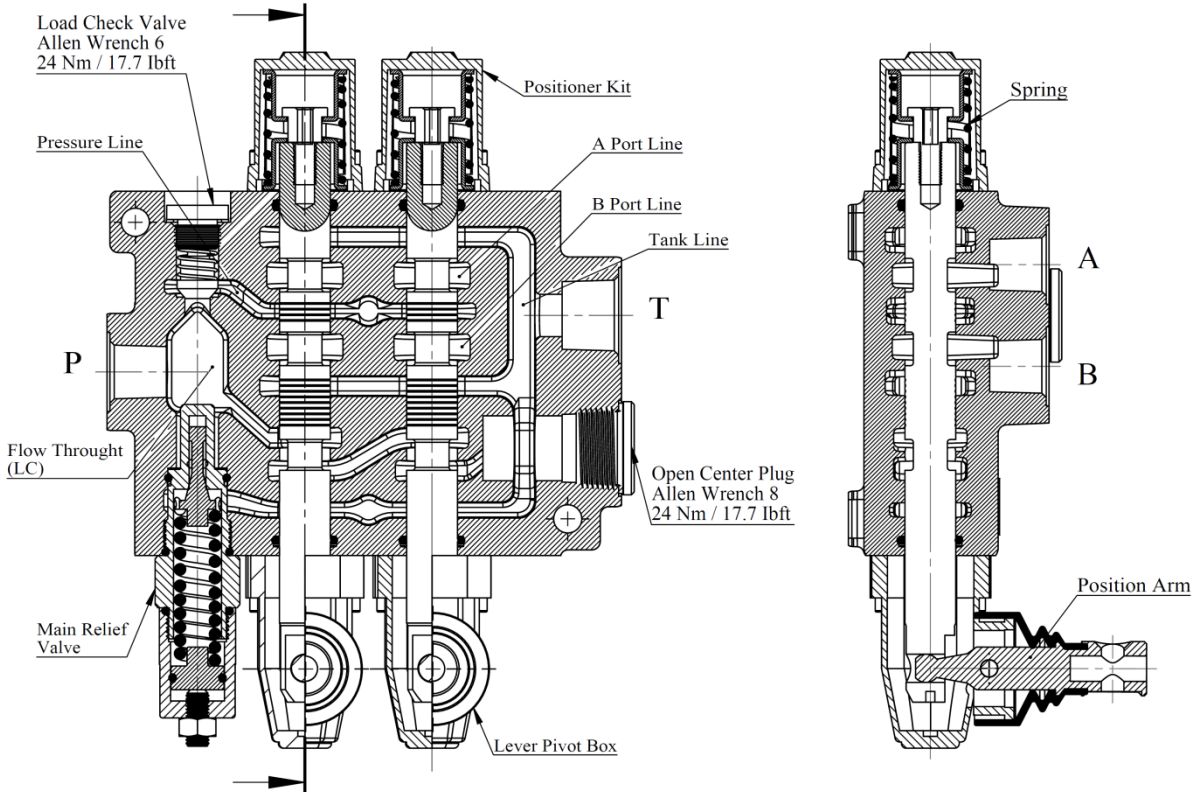

Code:GM- M70-2P / SMR2-120 / 1A-SR-STL/1A-SR-STL/PA1/SGT

## Performance Data And Curve

### Open Center - Pressure Drop (P-T)

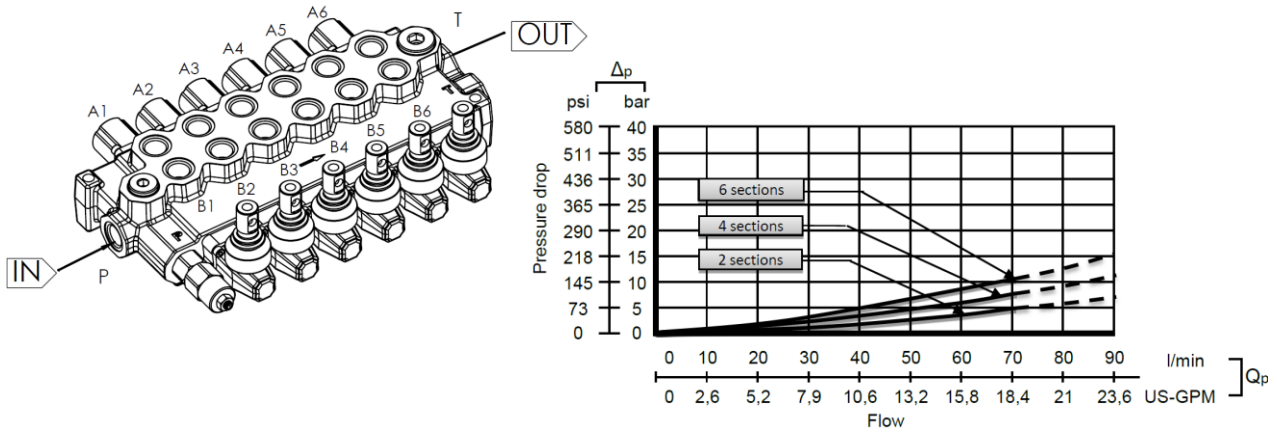

### Inlet to Work Port - Pressure Drop (P-A/B)

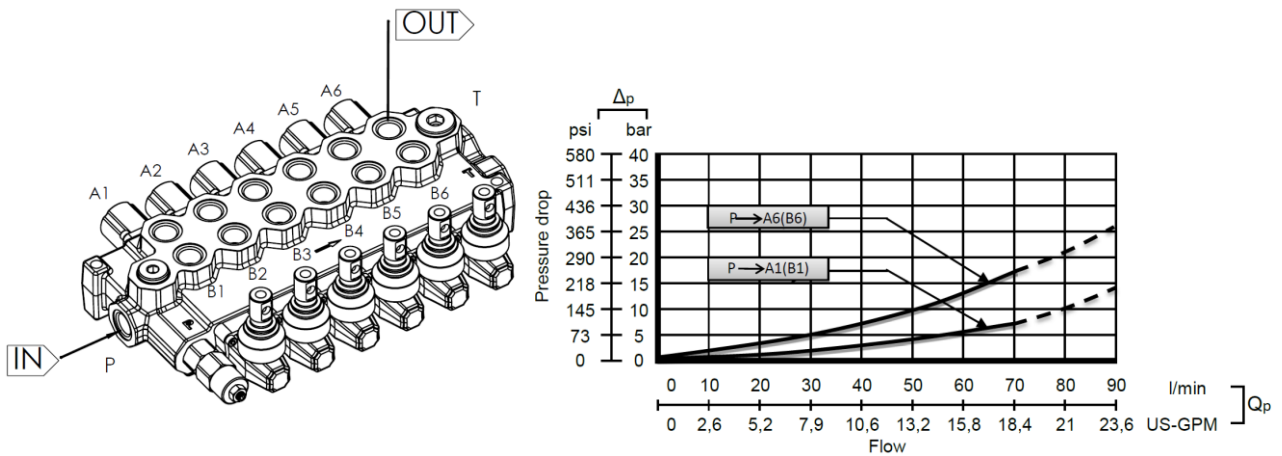

### Work Port to Outlet - Pressure Drop (A/B-T)

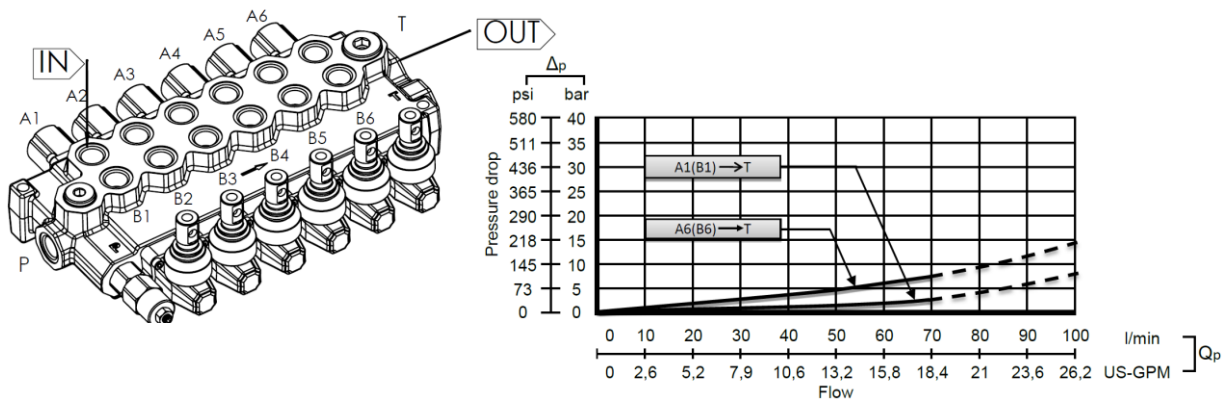

Note: Measured and chart value with spool type 1A.

**Inlet Relief Options**

**Direct Pressure Relief Valve**

Code:

**SMR2 – 120**

- Pressure Setting Bar in (Standard 120 bar)
- Standard Main Relief Spring Type -2

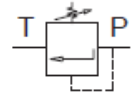
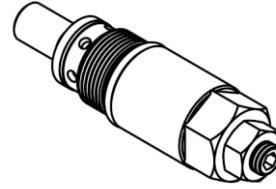

Performance Data:

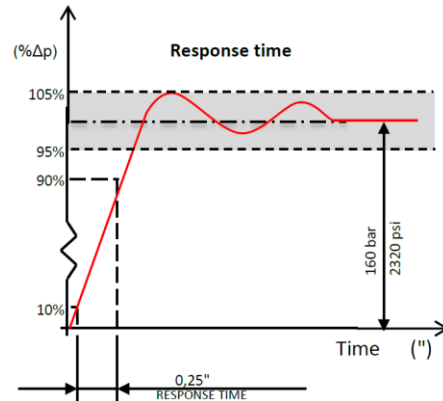
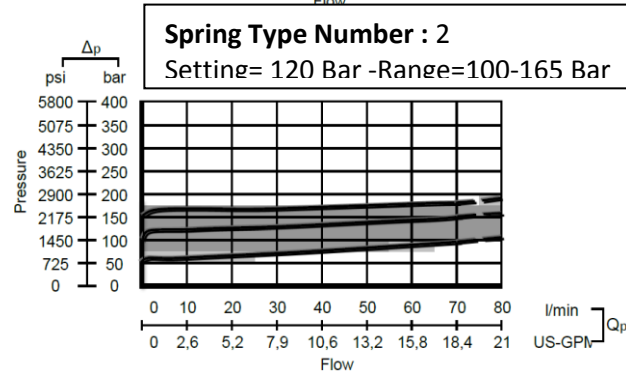
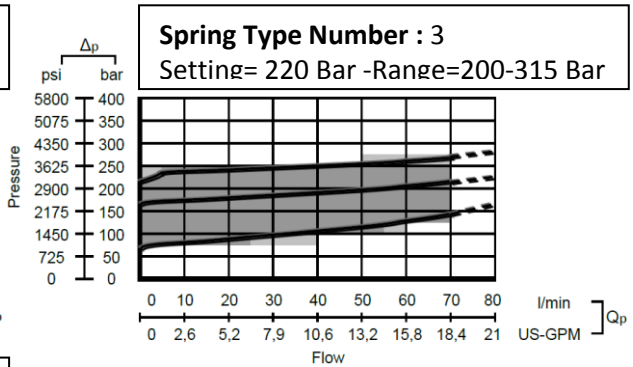
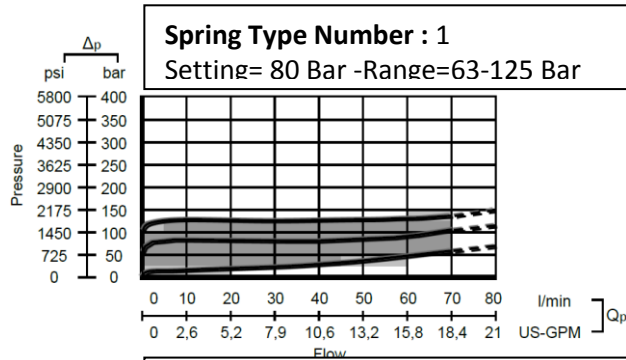

Adjustment Type on Valve:

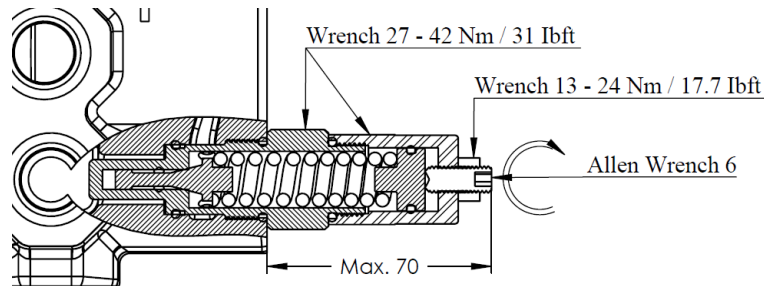

**Relief Blanking Plug - WM**

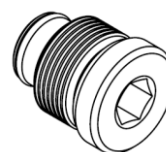
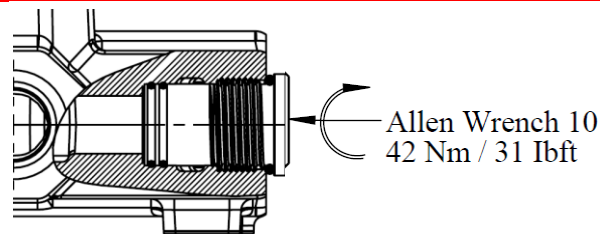

## Ordering Codes

### Order example

**GM M70-1P /SMR2-120 /1A-SR-STL/ 1A-80P-STL/ CO-PL1-P1 / SGT**

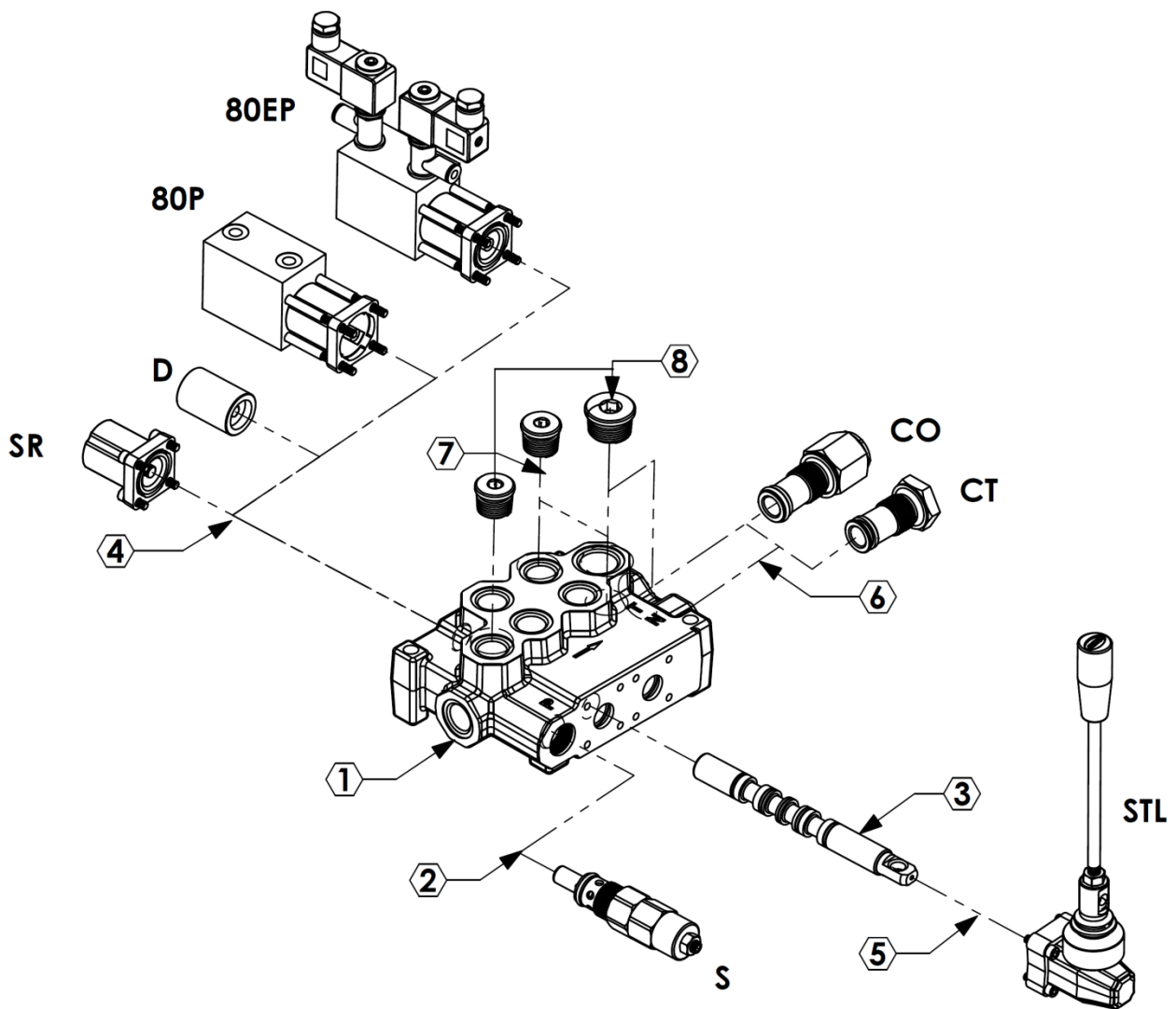
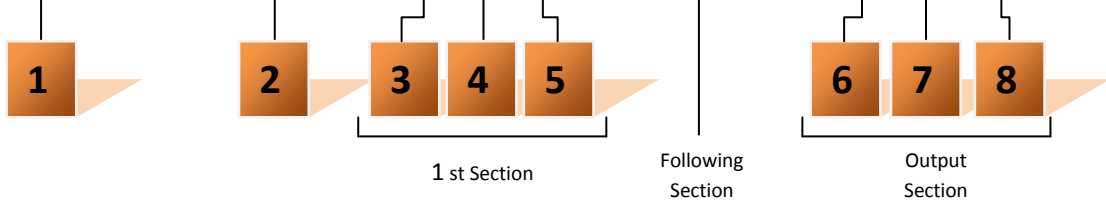



## Ordering Codes

### 1-Valve Type and Body

M80 =Valve Type - (M) - Monoblok  
(70) - Max. Flow Rate

- 1P =Body for 1 Section - (1BM170100)
- 2P =Body for 2 Sections - (1BM270100)
- 3P =Body for 3 Sections - (1BM370100)
- 4P =Body for 4 Sections - (1BM470100)
- 5P =Body for 5 Sections - (1BM570100)
- 6P =Body for 6 Sections - (1BM670100)

### 2-Pressure Relief Options

SMR = Standard direct pressure relief valve

**SMR1-080** – (2SMR170080)–Range 63-125 bar  
Setting 80 bar

**SMR2-120** – (2SMR270120)–Range 100-165 bar  
Setting 120 bar

**SMR3-220** – (2SMR370220)–Range 200-315 bar  
Setting 220 bar

### 3-Spool Options

1A -(3SM170110) – 3 Positions ,Double acting

2A -(3SM170120) – 3 Positions ,Double acting  
A to tank B Blocked

3A -(3SM170130) – 3 Positions ,Double acting  
B to tank A blocked

4A -(3SM170140) – 3 Positions ,Double acting  
A and B tank

5A -(3SM170150) – 3 Positions ,Single acting on  
A (A to tank)

6A -(3SM170160) – 3 Positions ,Single acting on  
B (B to tank)

### 4- Spool Positioners

**SR**=Spring Return in neutral position –  
(4SR080100)

**D** =Detent in position 1, neutral and 2 -  
(4D080100)

**80P**=ON/OFF Pneumatic – (445P045100)

**80EP**=12 VDC ON/OFF electro-pneumatic –  
(480EP080112)

24 VDC ON/OFF electro-pneumatic –  
(480EP080124)

### 5-Lever Options

**STL**=Standard Lever –(5STL080100)

### 6- Output Options

**PA1** =G3/4 Top and Side output- (6PL1080100)

**CO** =G3/4 Carry-Over Connector -(6CO080100)

**CT** = G3/4 Carry-Over Plug - -(6CT070100)

### 7-Ports Plug Options

**PL1** =Plug for single action spool for 2A-3A  
G3/4 –(7PL1080100)

**PL2** =Plug for single action spool for 2A-3A  
G1/2- (7PL1080100)

### 8- Ports Output Plug Options

**PA1** =G3/4 Top and side input –output-  
(8PA1080100)

**PA2**=G1/2 Top and side input – (8PA2080100)

### HandLever

**L** =Standard HandLever (L=120mmxM8) -  
(7L040100)

## Spool Options

### Spool Type - 1A

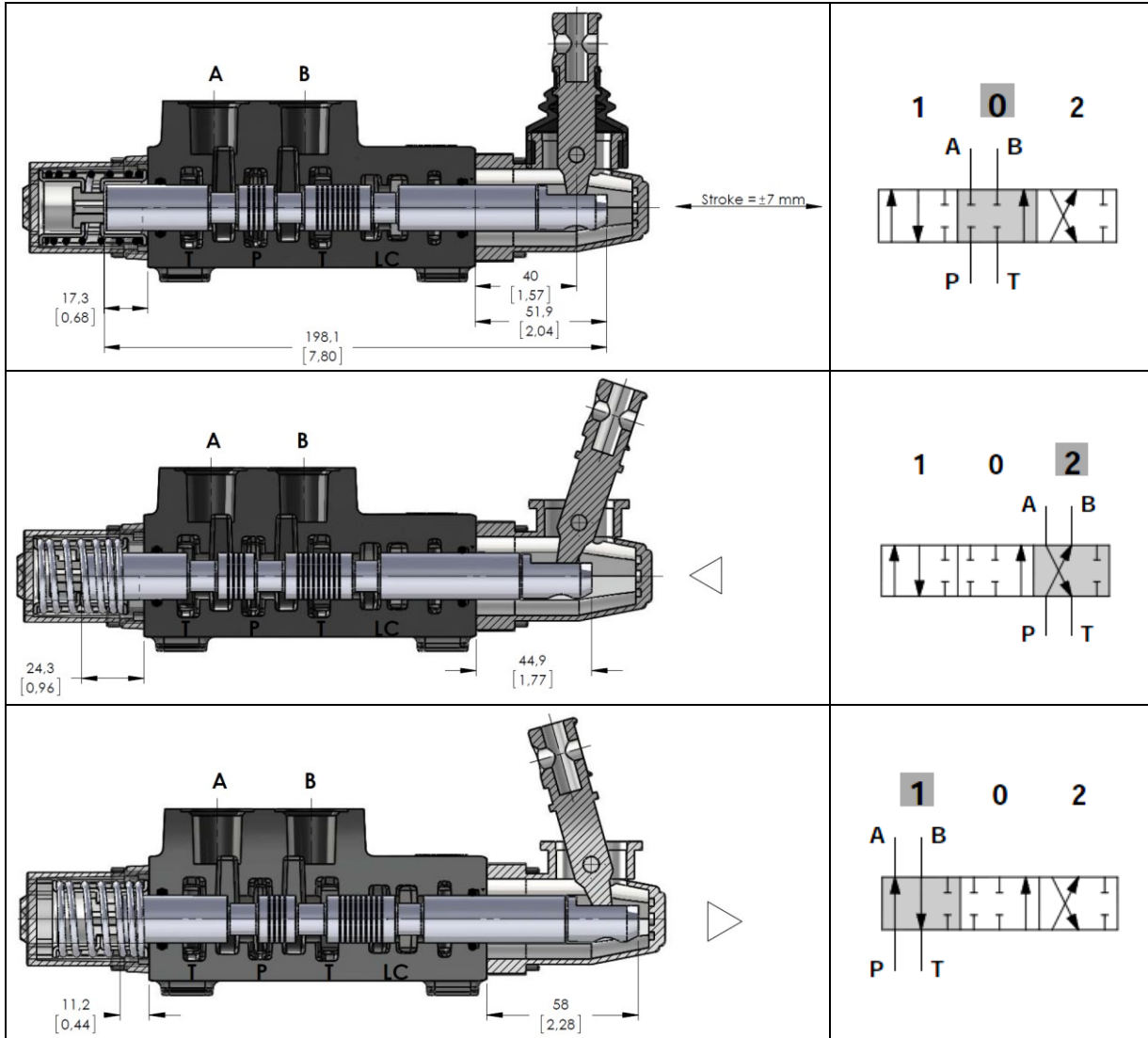

### Performance Curve And Data:

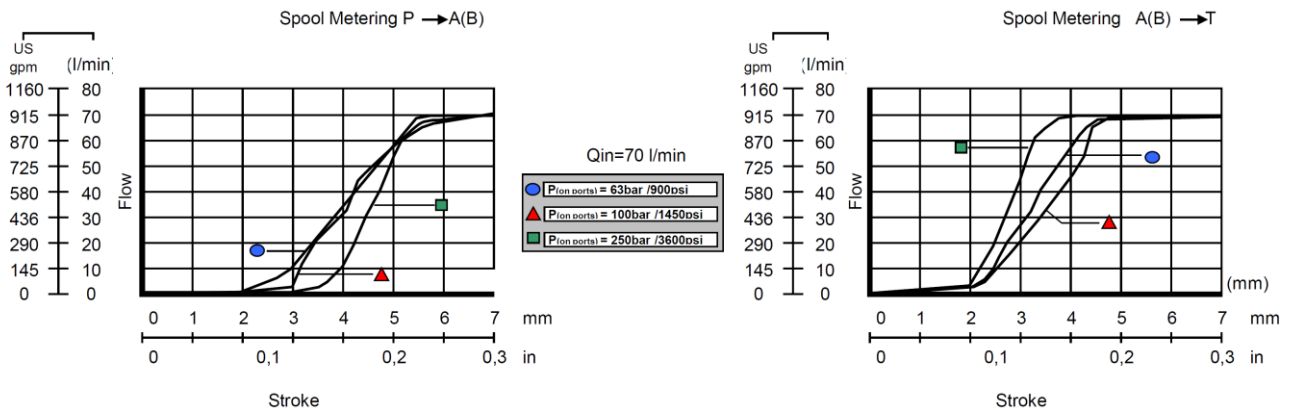

Spool Options

Spool Type - 2A

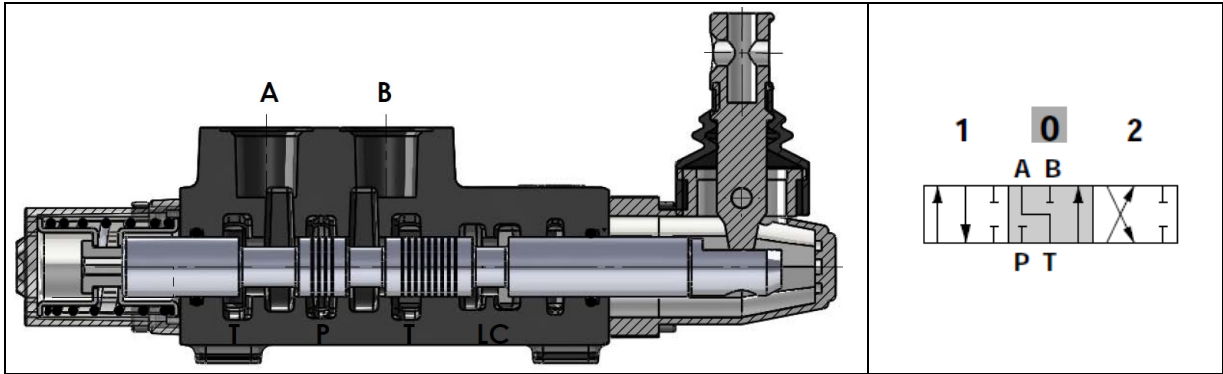

Spool Type - 3A

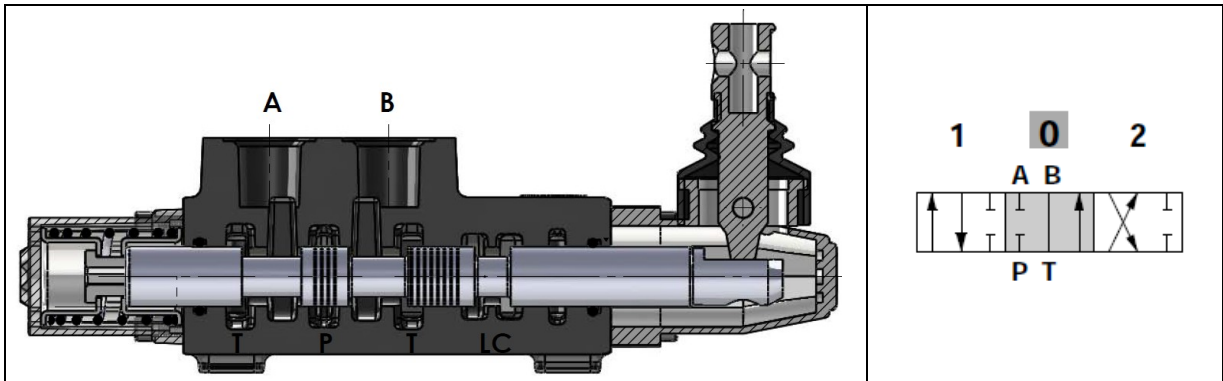

Spool Type - 4A

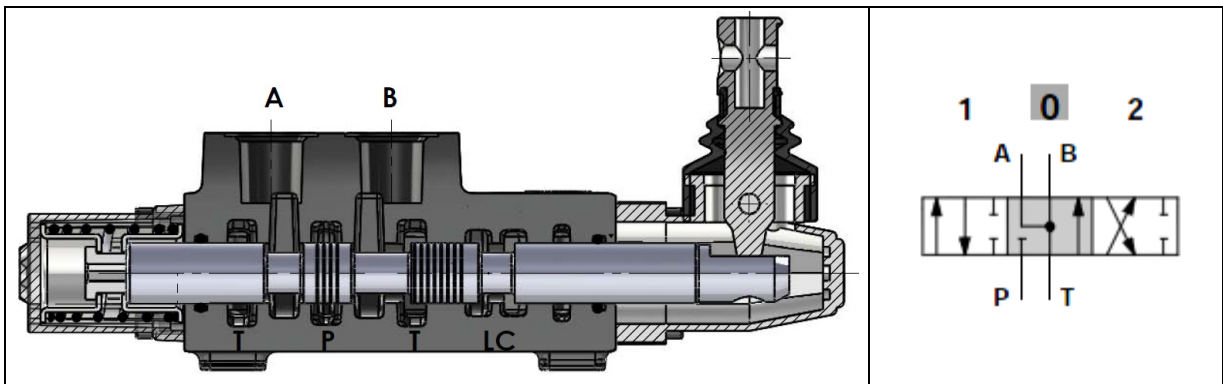

Spool Options

Spool Type - 5A

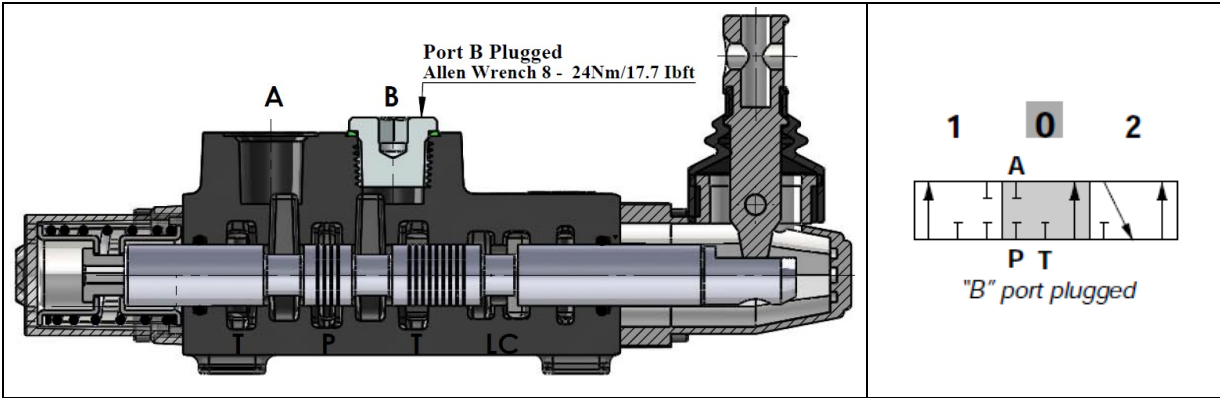

Spool Type - 6A

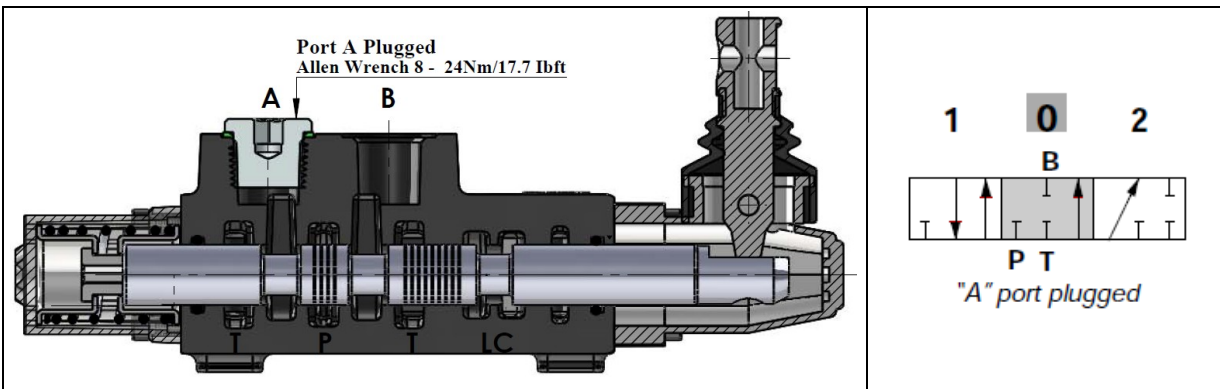

Spool Positioners – Side of Return

With Spring Return in Neutral Position

Kit No: SR	
Sectional Appearance	Diagram

With Detent

Kit No: D	
Sectional Appearance	Diagram

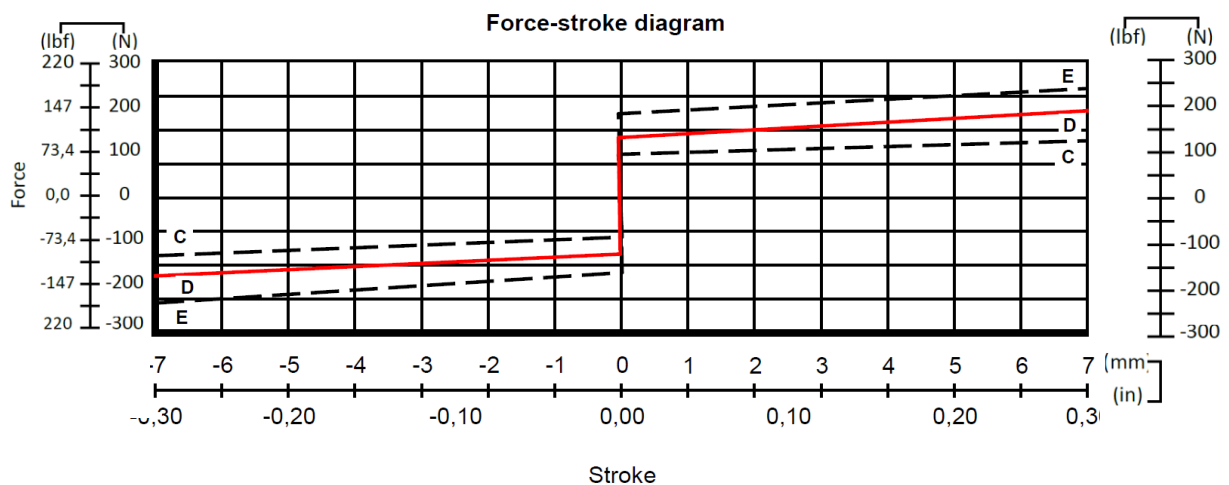

Spool Positioners – Side of Return

ON/OFF Pneumatic Control

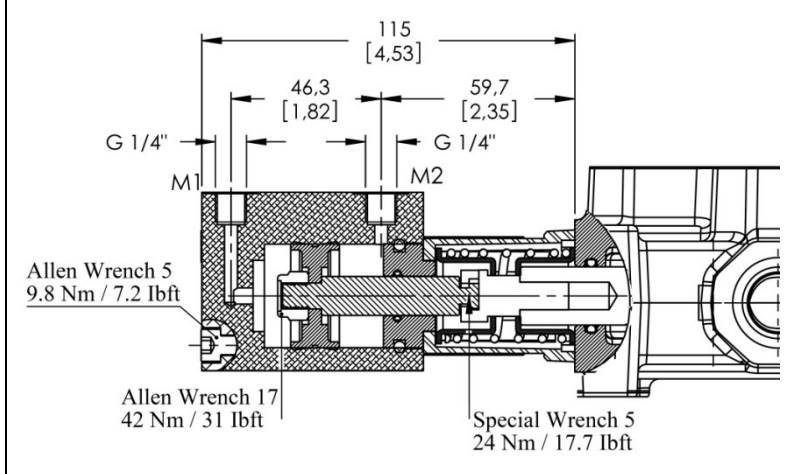
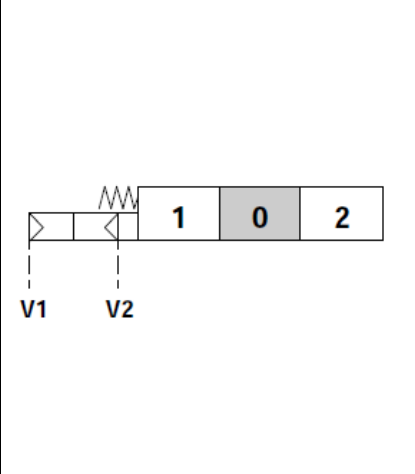
Kit No: <b>80P</b>	
Sectional Appearance	Diagram
 <p>Allen Wrench 5 9.8 Nm / 7.2 lbft</p> <p>Allen Wrench 17 42 Nm / 31 lbft</p> <p>Special Wrench 5 24 Nm / 17.7 lbft</p>	
<b>Operatig Features</b> Pilot Pressure .....: 6 Bar (Max. 10) / 87 Psi (Max. 145)	

ON/OFF Electro-Pneumatic Control

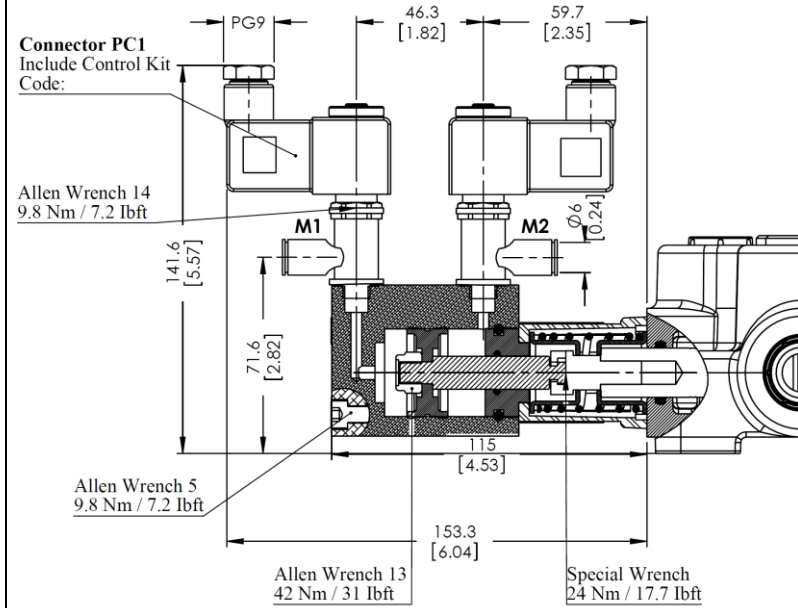
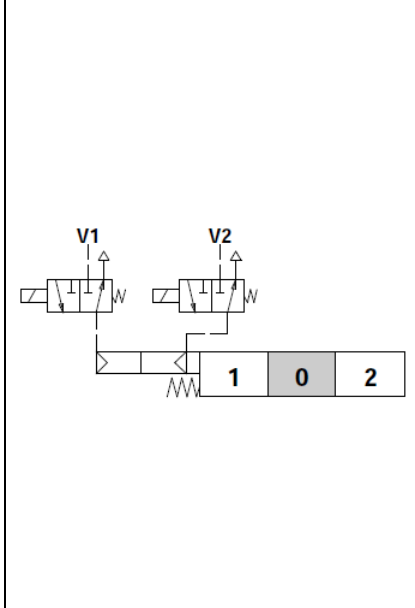
Kit No: <b>80EP</b>	
Sectional Appearance	Diagram
 <p>Connector PC1 Include Control Kit Code:</p> <p>Allen Wrench 14 9.8 Nm / 7.2 lbft</p> <p>Allen Wrench 5 9.8 Nm / 7.2 lbft</p> <p>Allen Wrench 13 42 Nm / 31 lbft</p> <p>Special Wrench 24 Nm / 17.7 lbft</p>	
<b>Operatig Features</b> Pilot Pressure .....: 6 Bar (Max. 10) / 87 Psi (Max. 145)	
<b>Selonoid Operating Features</b> Nominal Voltage.....: 12VDC / 24 VDC Power Rating.....: 6 W	

Spool Positioners – Side of Lever Control

Lever Controls

<p>Kit No: <b>STL - L0</b></p>	
<p>Sectional Appearance</p>	<p>Diagram</p>
<p>Kit No: <b>STL - L180</b></p>	
<p>Sectional Appearance</p>	<p>Diagram</p>
<p>Note: Aluminium with protection arm lever pivot box, it can be rotated 180°.</p>	

Outlet Port Options

Carry - Over Connection

Kit No: CO

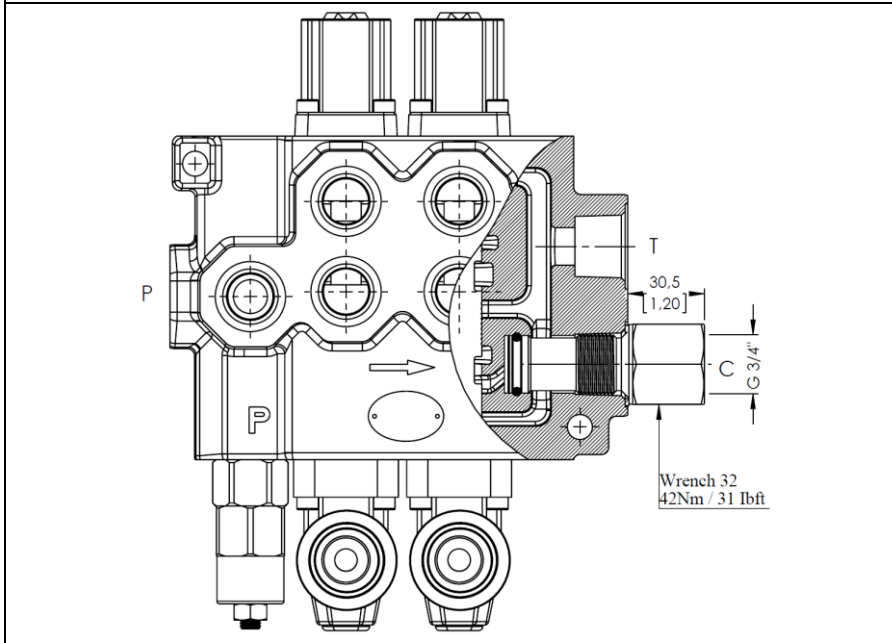

Sectional Appearance

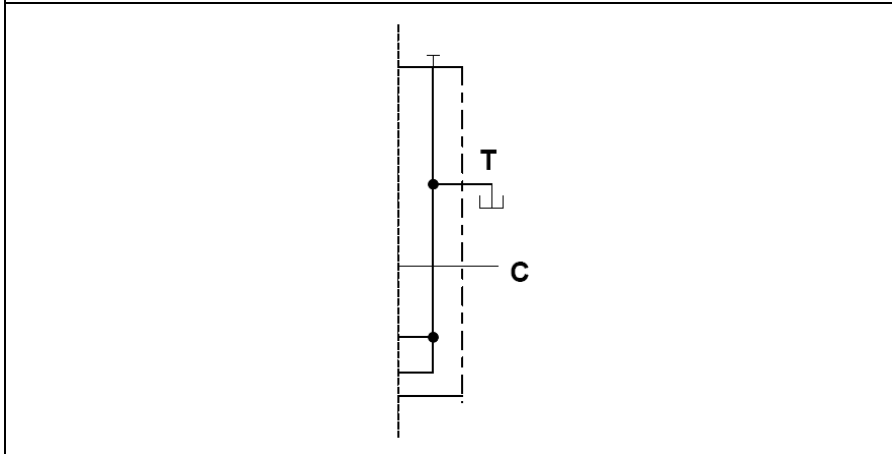

Hydraulic Circuit  
**Code:**GM- M70-2P / SMR2-120 / 1A-SR-STL/1A-SR-STL/CO-PA1/SGT

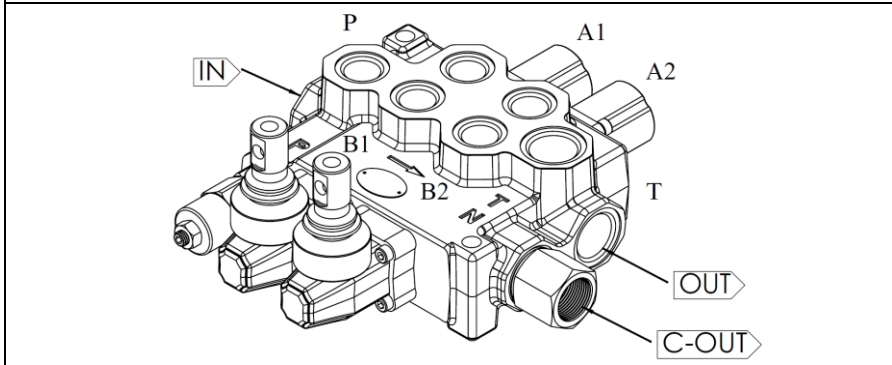

Direction of Port Connected

SGT : See page 5 for Standard center



Outlet Port Options

Closed Center

Kit No: CS

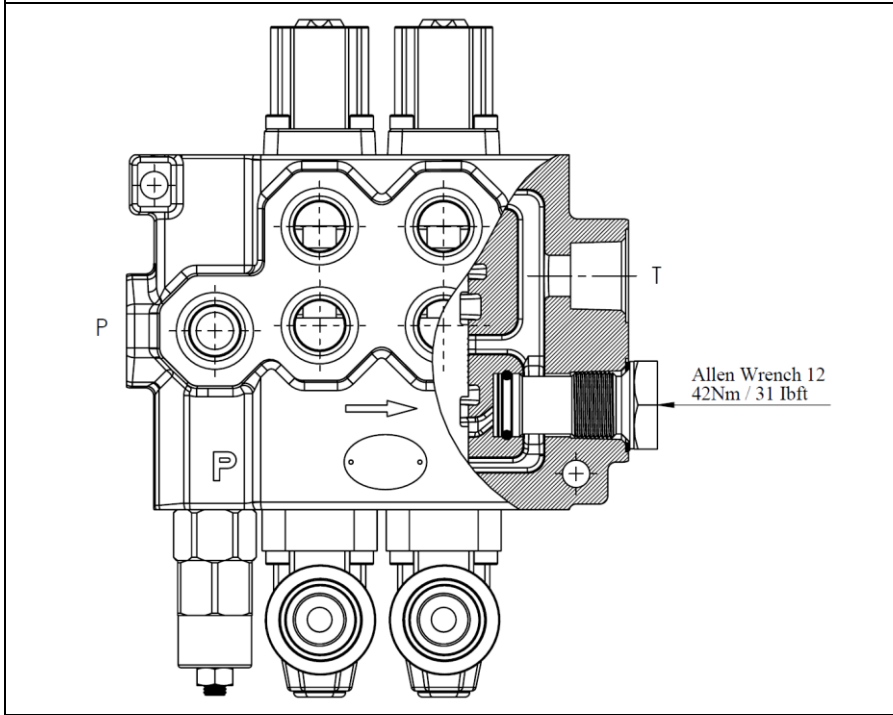

Sectional Appearance

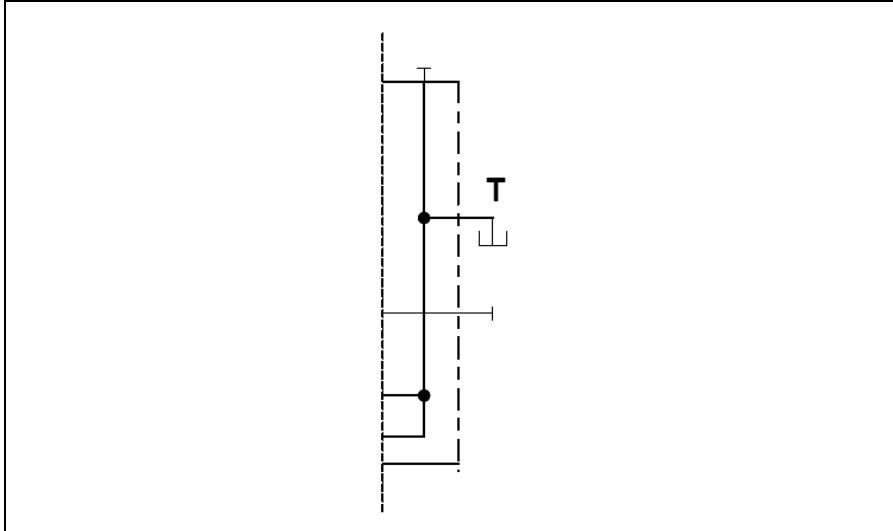

Hydraulic Circuit

**Code:**GM- M70-2P /  
SMR2-120 / 1A-SR-  
STL/1A-SR-STL/CT-  
PA1/SGT

## Installation and Maintenance

The GM M70 valve is assembled and tested as per the technical specification of this catalog.

Before the final installation on your equipment, follow the below recommendation:

- The valve can be assembled in any position, in order to prevent body deformation and spool sticking mount the product on a flat surface;
- In order to prevent the possibility of water entering the lever box and spool control kit, do not use high pressure wash down directly on the valve;
- Prior to painting, ensure plastic port plugs are tightly in place.

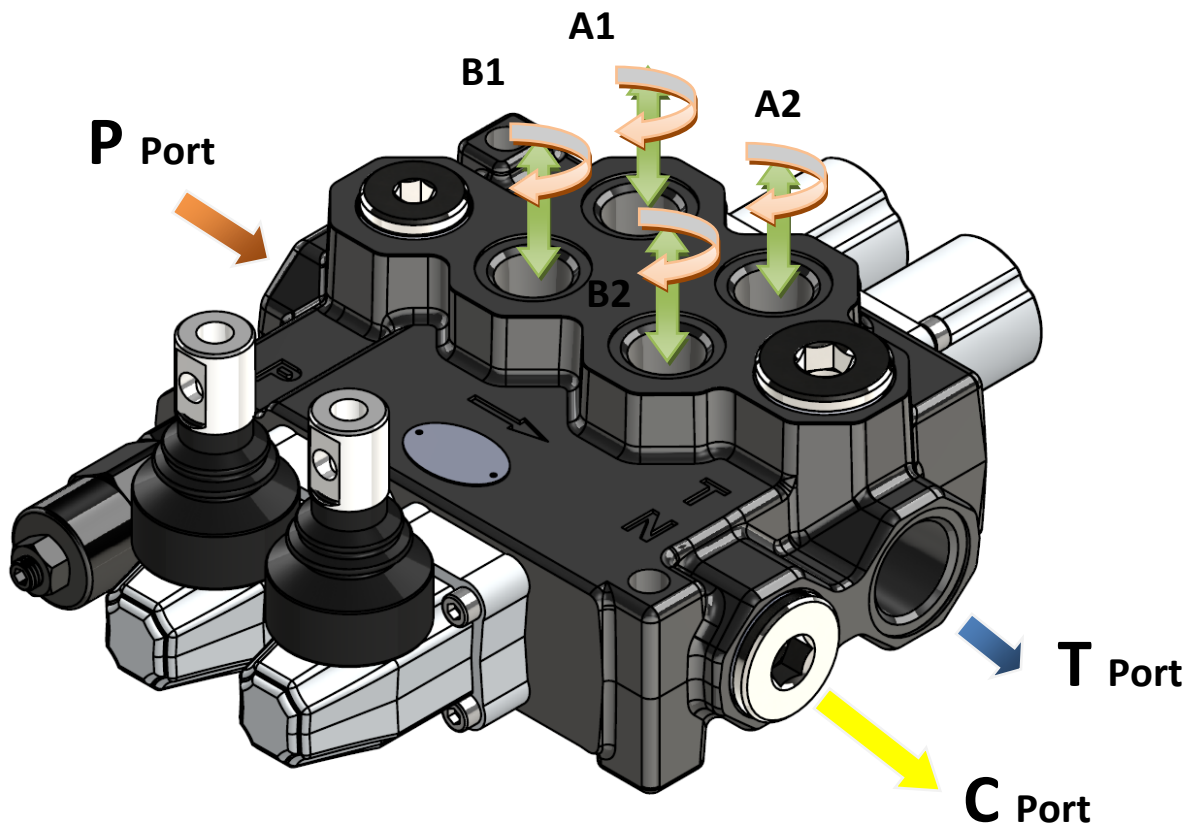

Threads Type (Nm / lbft)	P Port	A and B Port	T and C Port
BSP (ISO 228/1)	G 1/2	G 1/2	G 3/4
With O--Ring seal	50 / 36.9	50 / 36.9	70 / 51.6
With copper washer	60 / 44.3	60 / 44.3	70 / 51.6
With steel and rubber washer	60 / 44.3	60 / 44.3	70 / 51.6
BSP (ISO 228/1)	G 3/4	G 3/4	G 3/4
With O--Ring seal	70 / 51.6	70 / 51.6	70 / 51.6
With copper washer	70 / 51.6	70 / 51.6	70 / 51.6
With steel and rubber washer	70 / 51.6	70 / 51.6	70 / 51.6
UN--UNF (ISO 11926--1)	11/16--12 UNF--2B	9/16--18 UNF--2B	11/16--12 UNF--2B
With O--Ring seal	95 / 70	30 / 22.1	95 / 70
METRIC (ISO 262)	M27 x 2	M22 x 1.5	M27 x 2
With O--Ring seal	100 / 73.8	50 / 36.9	100 / 73.8
With copper washer	100 / 73.8	60 / 44.3	100 / 73.8
With steel and rubber washer	100 / 73.8	60 / 44.3	100 / 73.8

## Technical Data

### Ports Dimensional Data

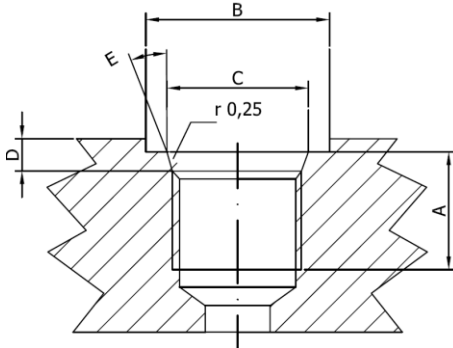

SAE UN-UNF (ISO 725)							
Dimensions		7/8-14 UNF SAE10		1"1/16-12 UN SAE12		1"5/16-12 UN SAE16	
mm	in						
A		17	0,67	20	0,79	20	0,79
B		34	1,34	41	1,61	49	1,92
C		23,9	0,94	29,2	1,15	35,5	1,40
D		2,5	0,10	3,3	0,13	3,3	0,13
E		15°		15°		15°	

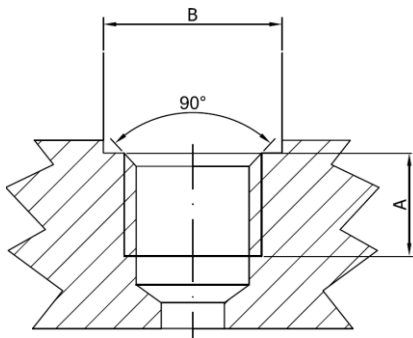

BSP (ISO 228)							
Dimensions		G 1/2"		G 3/4		G 1	
mm	in						
A		16	0,63	18	0,71	20	0,79
B		27	1,06	33	1,30	40	1,57

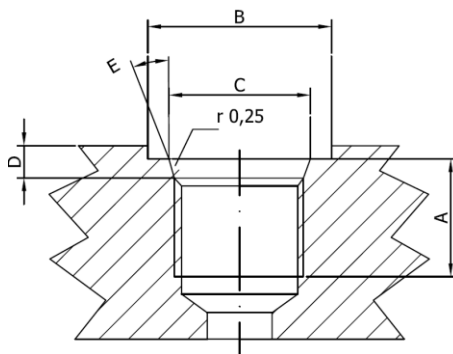

METRIC (ISO 262)							
Dimensions		M22x1,5 ISO 262		M27x2 ISO 262			
mm	in						
A		16	0,63	18	0,71		
B		31,5	1,24	37,7	1,48		