

DETAILED TECHNICAL CATALOGUE

SECTIONAL DIRECTIONAL  
CONTROL VALVES

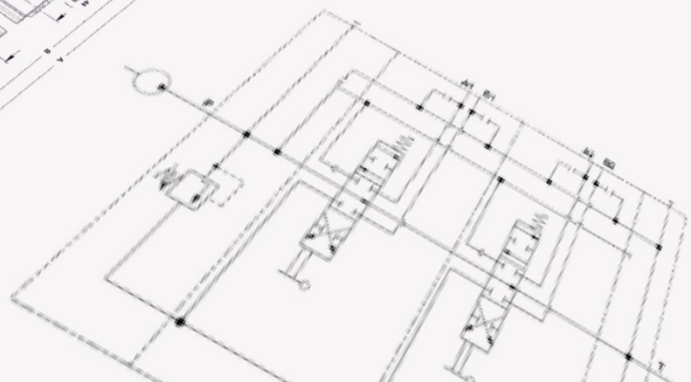

**GM-PD80**

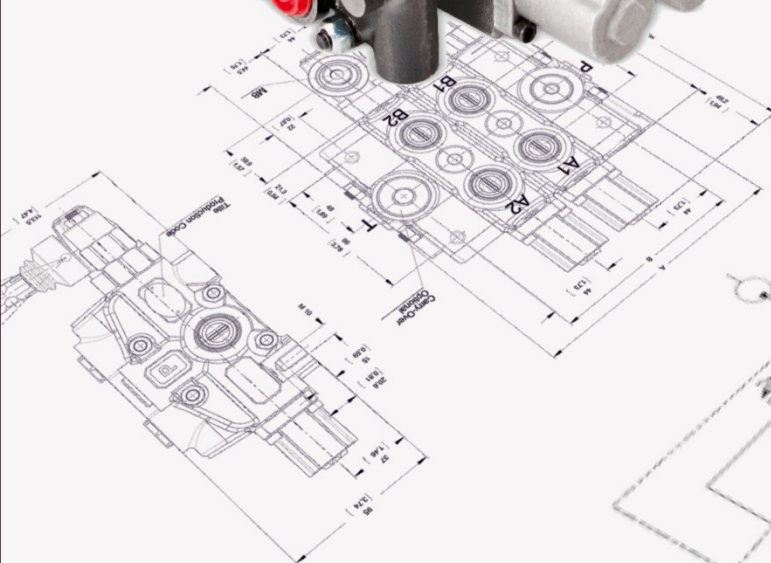

[www.gemmaautomotive.com](http://www.gemmaautomotive.com)



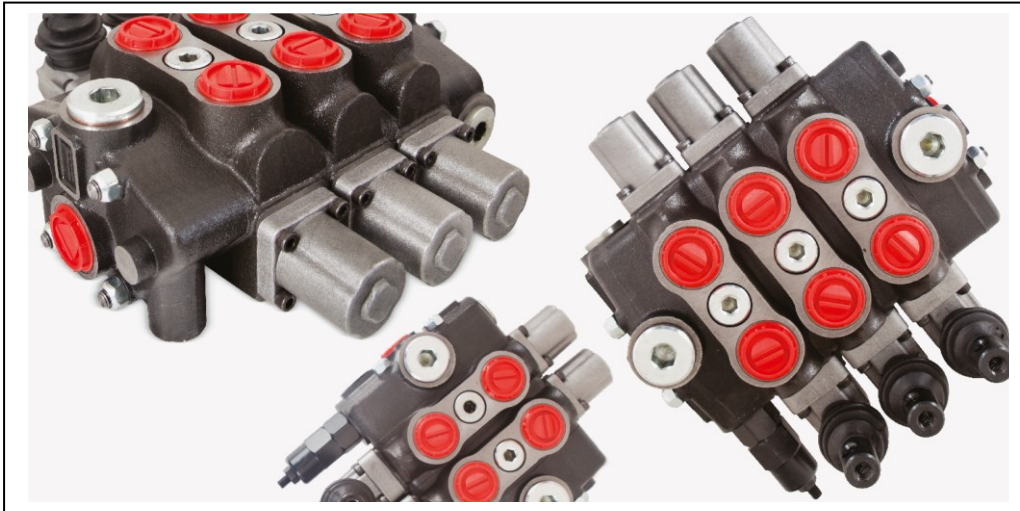

## Contents

<i>Working Conditions</i>	3
<i>Dimensional Data</i>	4
<i>Hydraulic Circuit</i>	5
<i>Performance Data And Curve</i>	9
<i>Inlet Relief Options</i>	10
<i>Ordering Codes</i>	12
<i>Inlet Cover- Pump Side</i>	14
<i>Spool Options</i>	16
<i>Spool Positioners – Side of Return</i>	19
<i>Working Section Kit</i>	21
<i>Spool Positioners – Side of Lever Control</i>	22
<i>Outlet Cover- Tank Side</i>	23
<i>Port Valves Options</i>	25
<i>Installation and Maintenance</i>	28
<i>Technical Data</i>	29

## Additional Informations

**Note:**This catalog shows the product in the most standard configurations. For Other Configurations, more detailed information or special request, Please contact Customer Service Dept.

**Warning!** :All specifications of this catalog refer to the standard product at this date (02/2011) . GEMMA, oriented to a continuous improvement, reserves the right to discontinue, modify or revise the specifications, without notice.

**GEMMA IS NOT RESPONSIBLE FOR ANY DAMAGE CAUSED BY AN INCORRECT USE OF THE PRODUCT.**

## Working Conditions

Nominal Flow Rating / Displacement	80 l/min	21 U.S.G.P.M
Maximum Working Pressure (Series Circuit)	210 Bar	3050 PSI
Maximum Working Pressure (Parallel Circuit)	315 Bar	4600 PSI
Max Back Pressure	25 Bar	360 PSI
Oil Temperature with NBR Seals	-20 to 80 C°	-4 to 176 F°
with FPM (Viton) Seals	-20 to 100 C°	-4 to 212 F°
Oil Viskosity – Operating Range	From 10 to 75 mm <sup>2</sup> /s	From 10 to 75 cSt
Minumum / Maximum	10 / 400 mm <sup>2</sup> /s	10 / 400 cSt
Oil Filtration	≤30 μ	
Ambiant Temperature Range	-35 to 60 C°	-31 to 140 F°
Number Of Spools	1 to 12	
Internal Leakage (at 100 bar (1450 PSI), 40C° (110 F°), 46 cSt – A(B)—T)	3 cm <sup>3</sup> /min	0,18 in <sup>3</sup> /min
Max. Level Of Contamination	19/16 - ISO 4406	
Tie rod tightening torque	30 Nm	22 lbft

Not: This catalogue shows technical specifications measured with mineral oil of 46 mm<sup>2</sup>/s-46 cSt viscosity at 40 C° temperature.

## Features

- Simple, compact and heavy duty designed sectional valves from 1 to 12 sections for open and closed center hydraulic systems.
- Optionaly Carry-Over port only tandem circuit.
- Fitted with a main pressure relief valve.
- Interchangeable spool diametre is 18 mm – 0,71 in.
- Available manual, pneumatic, hydraulic and electro-pneumatic spool control kits.

## Dimensional Data

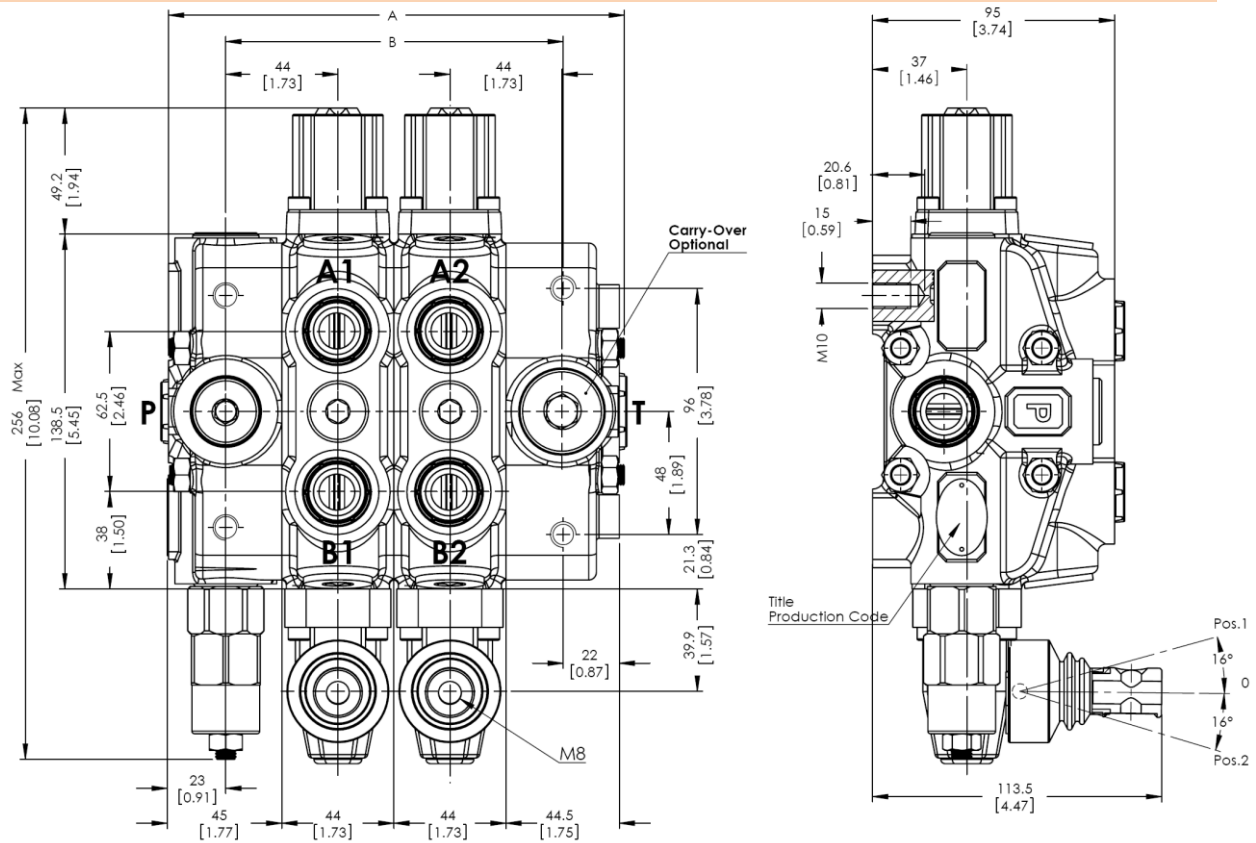

TYPE	A		B		Weight	
	mm	in	mm	in	Kg	lb
GM- PD80-1P	133	5.23	88	3.46	7.58	16.71
GM- PD80-2P	177	6.97	132	5.19	10.96	24.16
GM- PD80-3P	221	8.70	176	9.93	14.34	31.61
GM- PD80-4P	265	10.43	220	8.66	17.37	39.06
GM- PD80-5P	309	12.16	264	10.39	21.10	46.51
GM- PD80-6P	353	13.89	308	12.12	24.48	53.96
GM- PD80-7P	397	16.63	352	13.85	27.86	61.41
GM- PD80-8P	441	17.36	396	15.19	31.24	68.86
GM- PD80-9P	485	19.09	440	17.32	34.62	76.31
GM- PD80-10P	529	20.82	484	19.06	38.00	83.76
GM- PD80-11P	573	22.56	528	20.79	41.38	91.21
GM- PD80-12P	617	24.29	572	22.52	44.76	98.66

## Standart Threads

PORT	BSP (Iso 228)		UN-UNF (Iso 11926-1)	Metric (Iso 262)
	1/2" Series	3/4" Series		
<b>P</b> Inlet	G 1/2	G 3/4	7/8-14 UNF	M27x2
<b>A-B</b> Ports	G 1/2	G 3/4	3/4 - 16 UNF	M22x1.5
<b>T</b> Outlet	G 3/4	G 3/4	7/8-14 UNF	M27x2
Pneumatic	G 1/4	G 1/4	NPTF 1/8 - 27	NPTF 1/8 - 27
Carry-Over	G 3/8	G 3/8	G 3/8	G 3/8



## Hydraulic Circuit

### Parallel

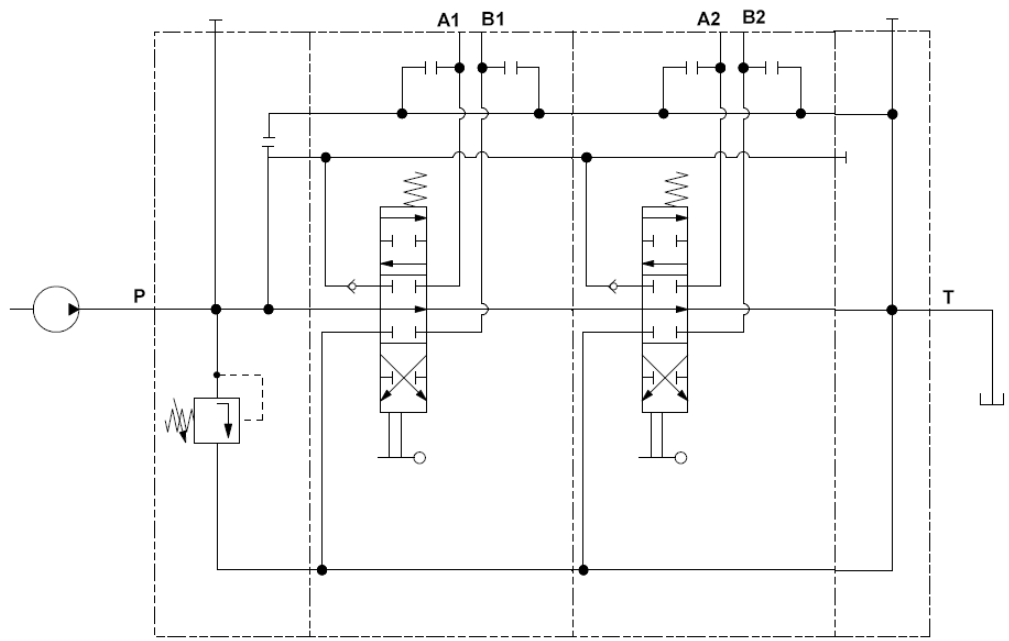
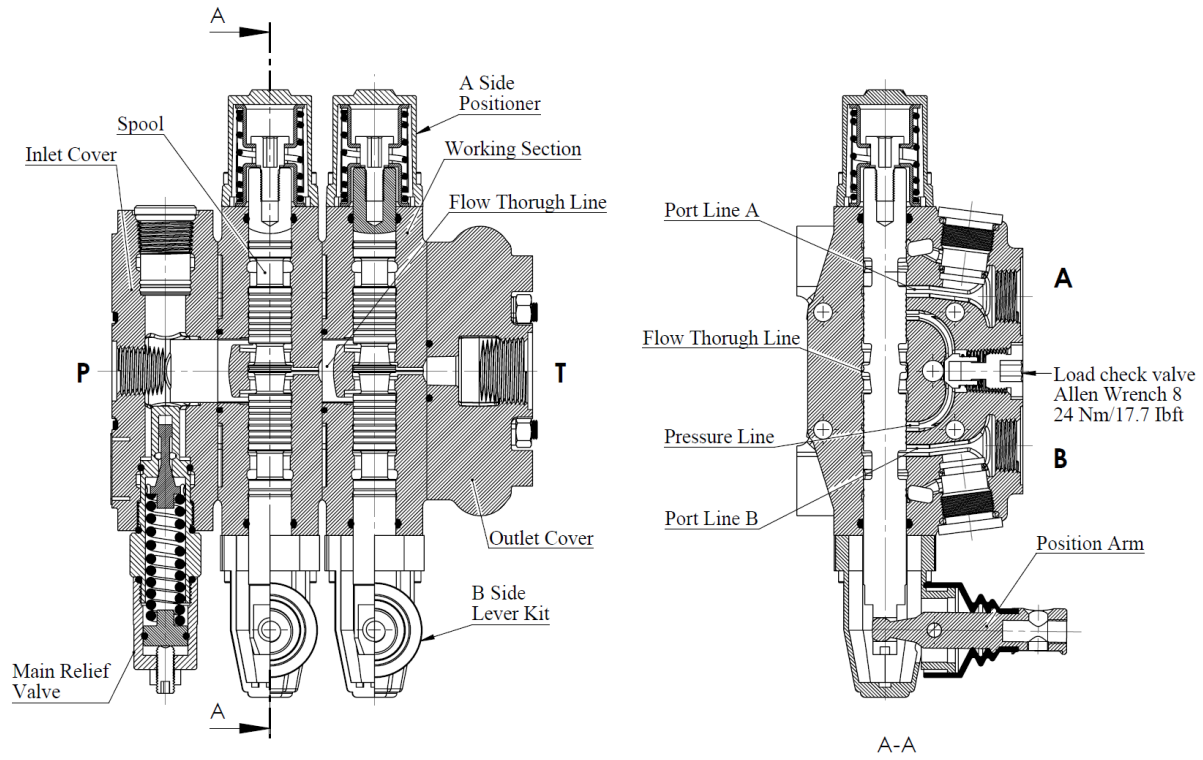

**Code:** GM- PD80-2P (SD(LA)-SMR2-125-PP )/P-1A-STL-SR/ P-1A-STL-SR/ SO-PT1 / SGT

Hydraulic Circuit

Inlet Cover – Pump Side

SD - Side inlet with direct pressure relief valve  
 TD - Top inlet with direct pressure relief valve  
 SP - Side inlet with relief valve blanking plug

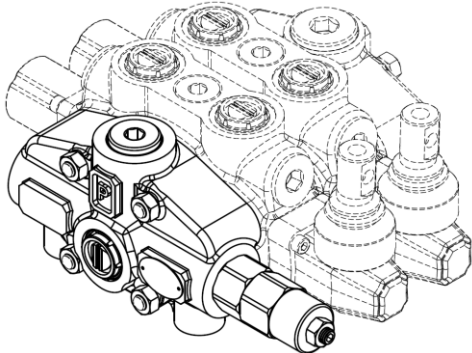
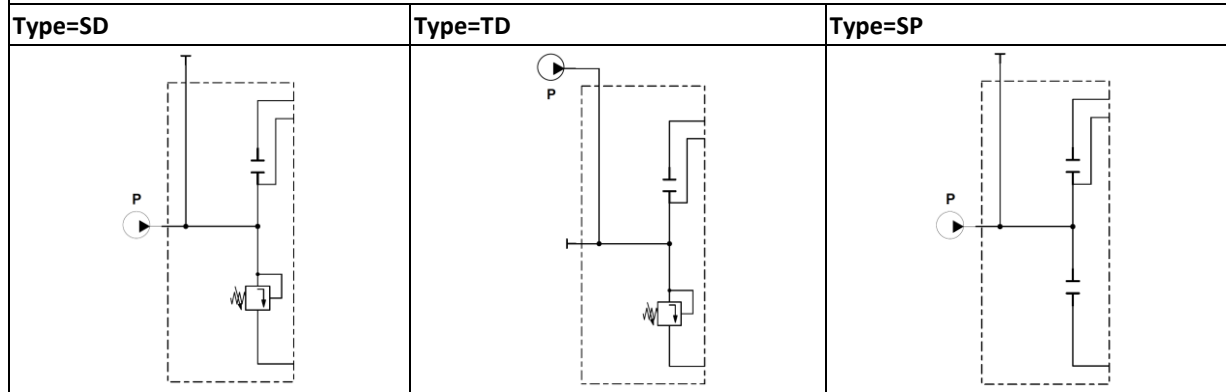
Working Sections

P – Parallel

Hydraulic Circuit

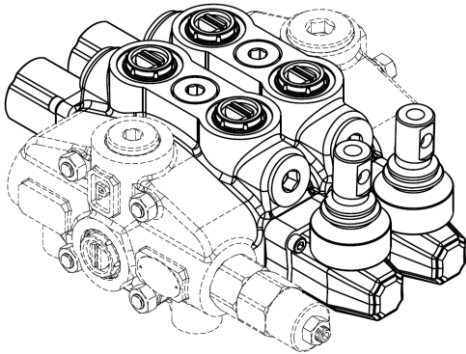
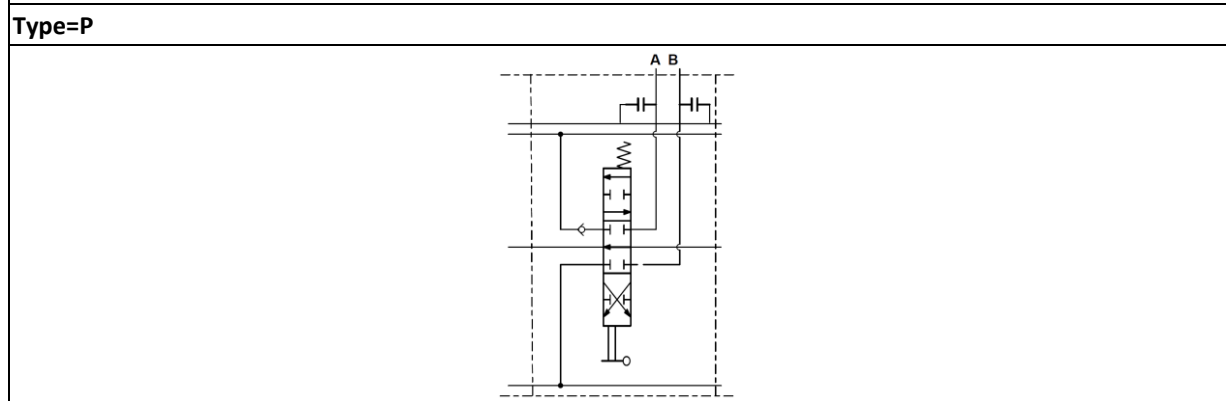
Outlet Cover (Tank Side)

SO - Side outlet  
 TO - Top outlet  
 TCO - Top outlet with carry-over  
 TC - Top outlet with closed centre

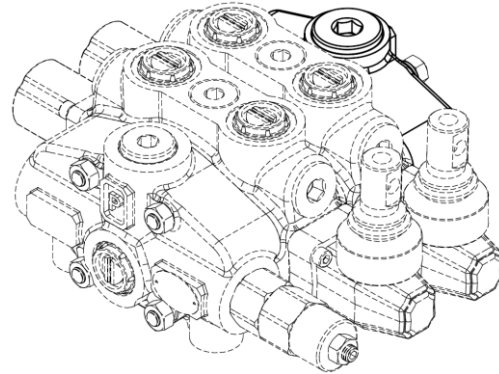

Type=SO	Type=TO	Type=TCO	Type=TC

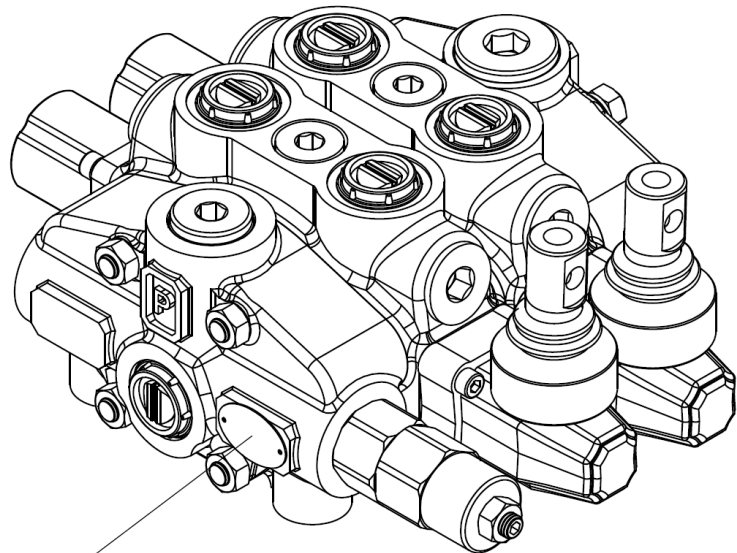

Valve Type  
 Production Batch  
 39.10 = Production Year - Week (2010/39)  
 101149 = Progressive Party Number

Hydraulic Circuit

Standard Configurations With Top Inlet And Outlet Ports - RH (Right Inlet)

A simmetrical body allows the reverse assembly of spool.

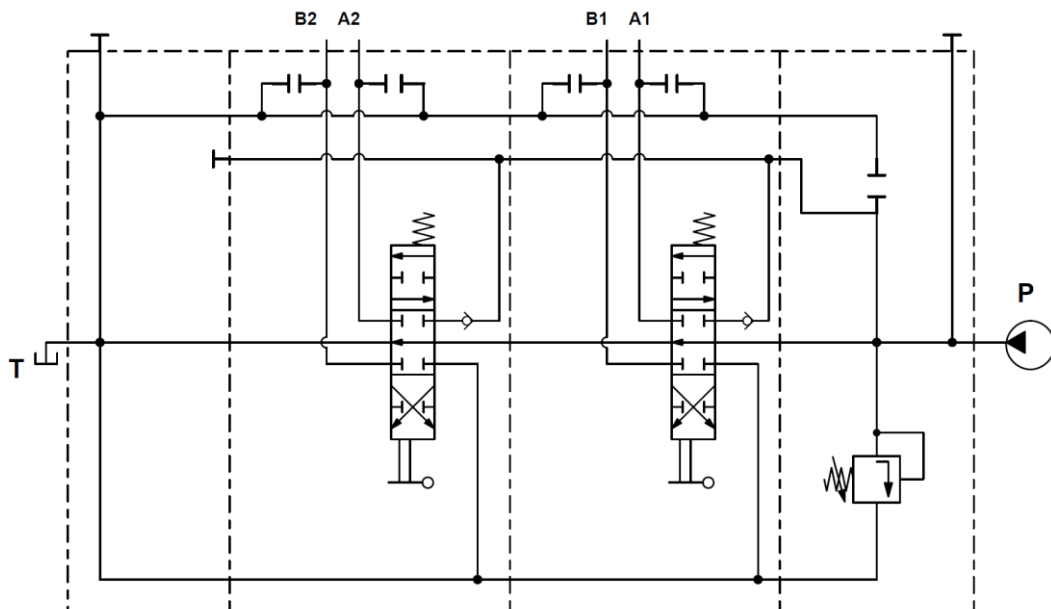
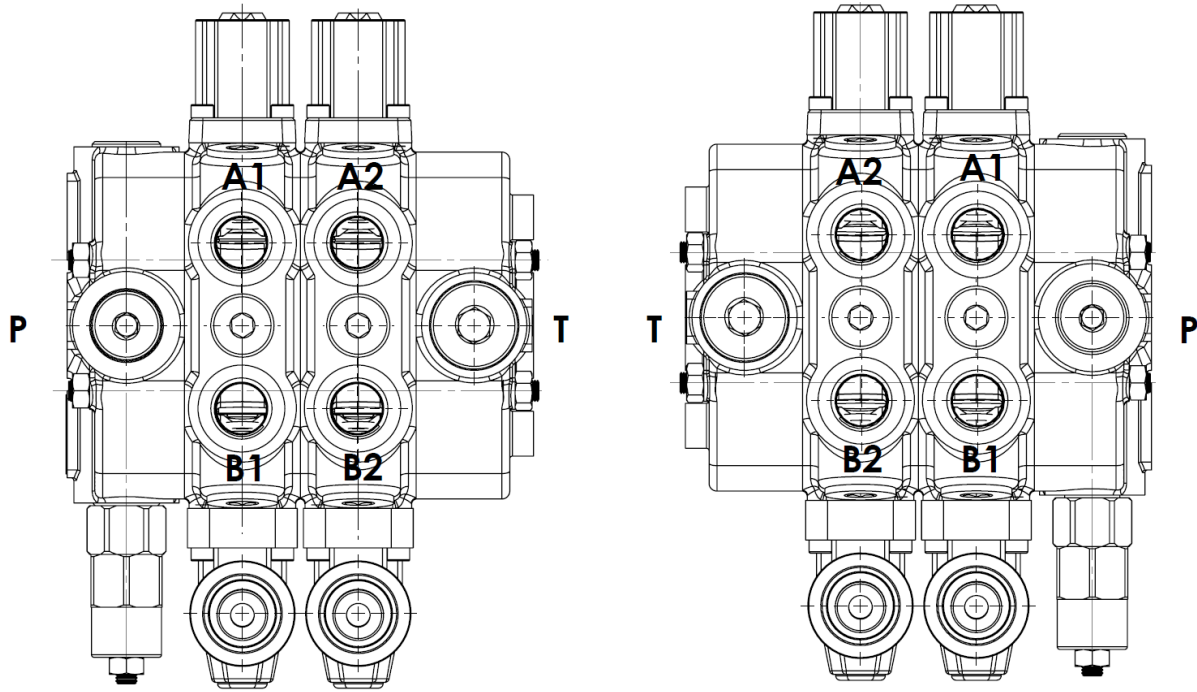

Code: GM- PD80-2P (SD(RA)-SMR2-125-PP )/P-1A-STL-SR/ P-1A-STL-SR/ SO-PT1 / SGT

## Performance Data And Curve

### Open Center - Pressure Drop (P-T)

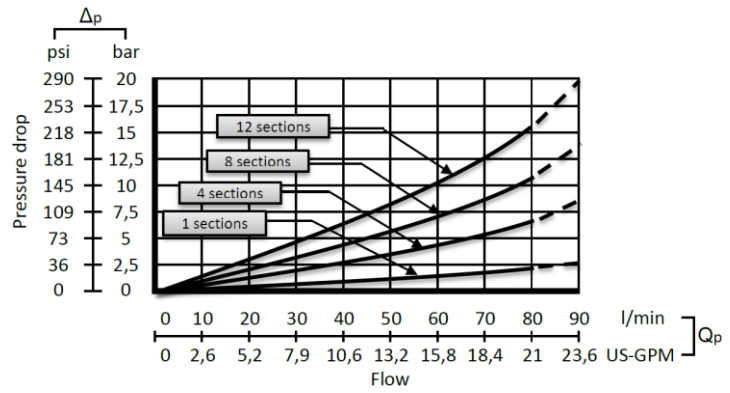
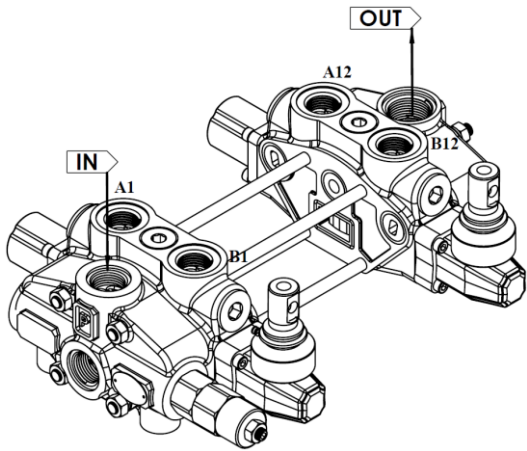

### Inlet to Work Port - Pressure Drop (P-A/B)

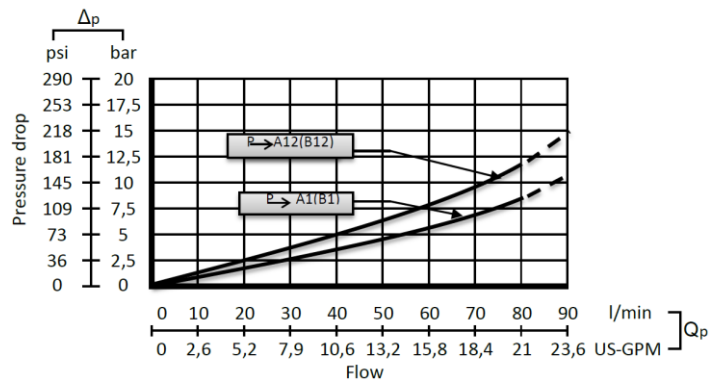
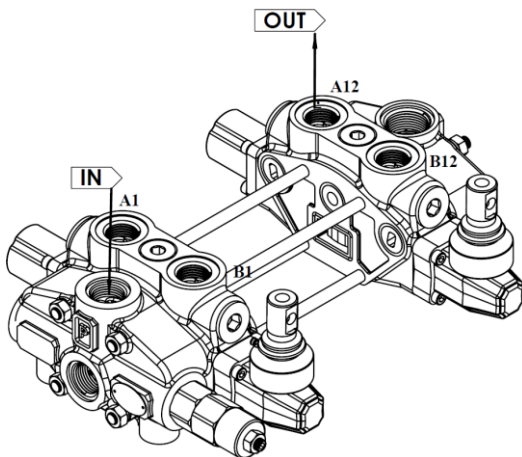

### Work Port to Outlet - Pressure Drop (A/B-T)

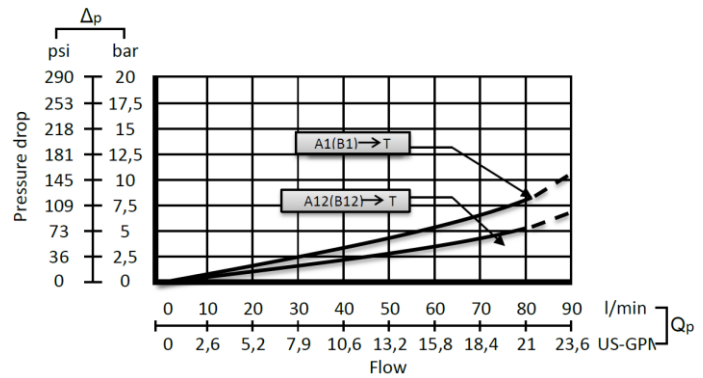
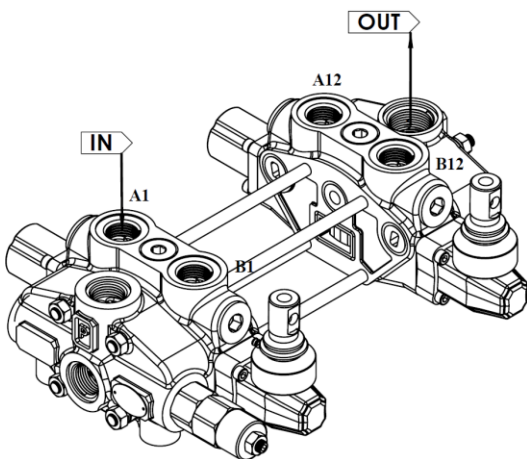



## Inlet Relief Options

### Direct Pressure Relief Valve

Code: \_\_\_\_\_

#### SMR2 – 125

- Pressure Setting Bar in (Standard 125 bar)
- Standard Main Relief Spring Type -2

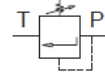
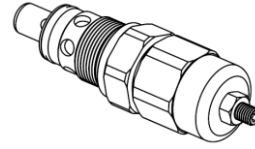

Performance Data: \_\_\_\_\_

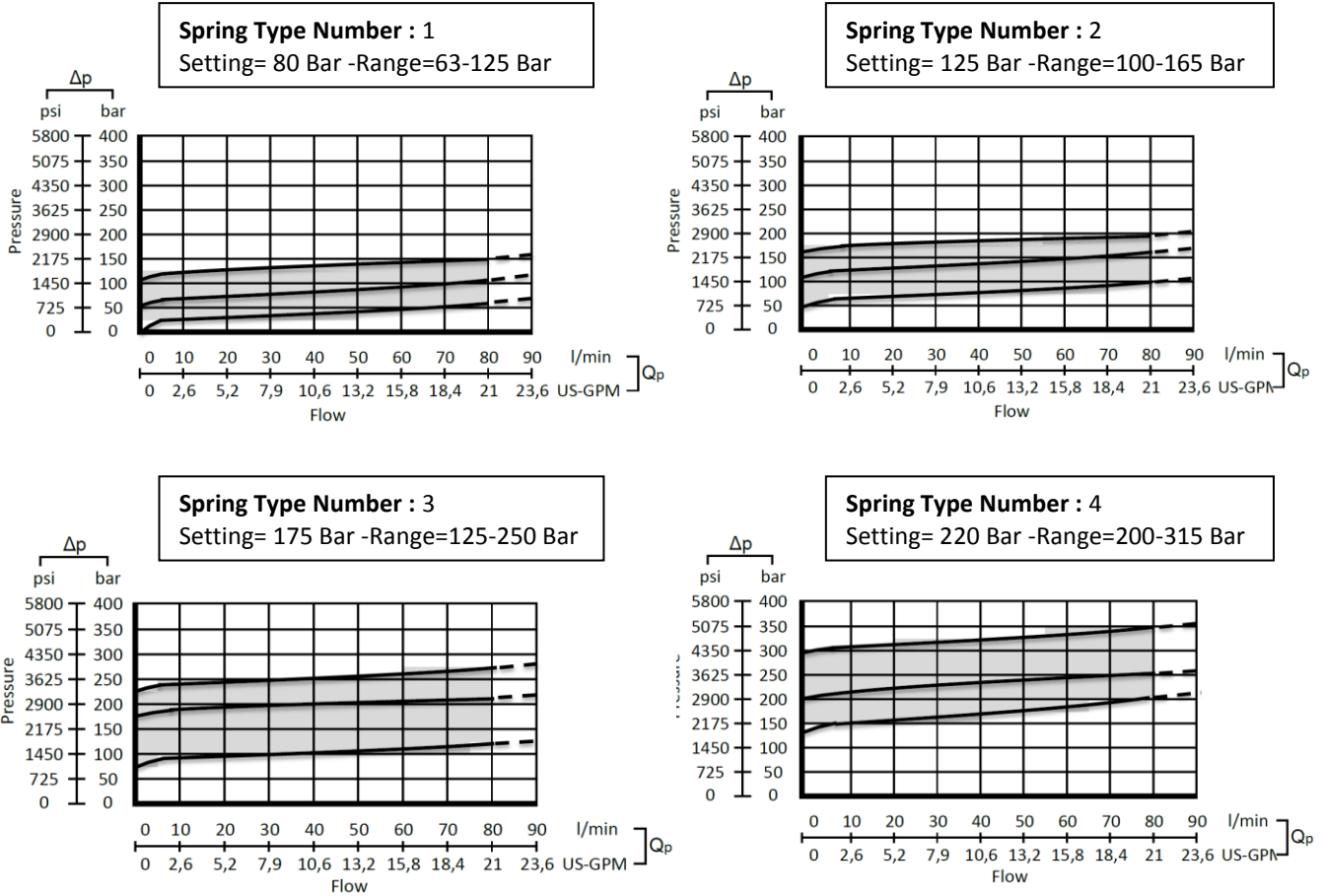

Adjustment Type on Valve: \_\_\_\_\_

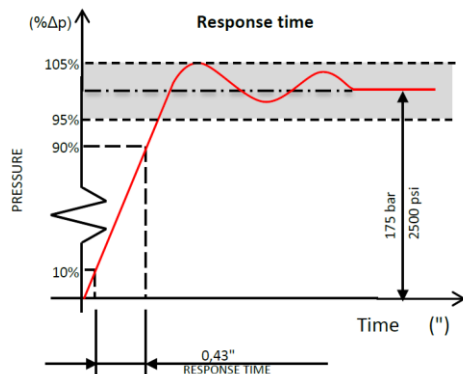
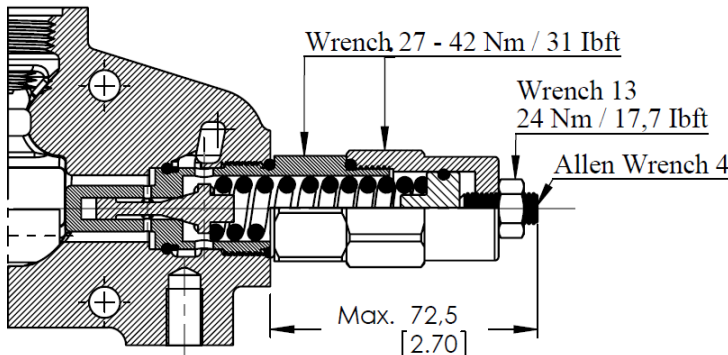

Inlet Relief Options

Direct Pressure Relief Valve

Kit No: PAC

<p>Sectional Appearance</p> <p>Wrench 22 - 24 Nm / 17.7 Ibft</p> <p>Wrench 27 - 41 Nm / 31 Ibft</p> <p>15.5 [0.61]</p>	<p>Diagram</p>																																												
<p>Performance Data</p> <p style="text-align: center;">Pressure drop</p> <table border="1"> <caption>Pressure Drop vs. Flow Data</caption> <thead> <tr> <th>Flow (l/min)</th> <th>Flow (US-GPM)</th> <th>Pressure (psi)</th> <th>Pressure (bar)</th> </tr> </thead> <tbody> <tr><td>0</td><td>0</td><td>0</td><td>0</td></tr> <tr><td>10</td><td>2.6</td><td>~10</td><td>~0.7</td></tr> <tr><td>20</td><td>5.2</td><td>~20</td><td>~1.4</td></tr> <tr><td>30</td><td>7.9</td><td>~35</td><td>~2.5</td></tr> <tr><td>40</td><td>10.6</td><td>~50</td><td>~3.5</td></tr> <tr><td>50</td><td>13.2</td><td>~70</td><td>~5.0</td></tr> <tr><td>60</td><td>15.8</td><td>~95</td><td>~6.8</td></tr> <tr><td>70</td><td>18.4</td><td>~125</td><td>~9.0</td></tr> <tr><td>80</td><td>21.0</td><td>~160</td><td>~11.5</td></tr> <tr><td>90</td><td>23.6</td><td>~200</td><td>~14.5</td></tr> </tbody> </table>		Flow (l/min)	Flow (US-GPM)	Pressure (psi)	Pressure (bar)	0	0	0	0	10	2.6	~10	~0.7	20	5.2	~20	~1.4	30	7.9	~35	~2.5	40	10.6	~50	~3.5	50	13.2	~70	~5.0	60	15.8	~95	~6.8	70	18.4	~125	~9.0	80	21.0	~160	~11.5	90	23.6	~200	~14.5
Flow (l/min)	Flow (US-GPM)	Pressure (psi)	Pressure (bar)																																										
0	0	0	0																																										
10	2.6	~10	~0.7																																										
20	5.2	~20	~1.4																																										
30	7.9	~35	~2.5																																										
40	10.6	~50	~3.5																																										
50	13.2	~70	~5.0																																										
60	15.8	~95	~6.8																																										
70	18.4	~125	~9.0																																										
80	21.0	~160	~11.5																																										
90	23.6	~200	~14.5																																										

Relief Blanking Plug - SP

Allen Wrench 10  
42 Nm / 31 Ibft

## Ordering Codes

### Order example

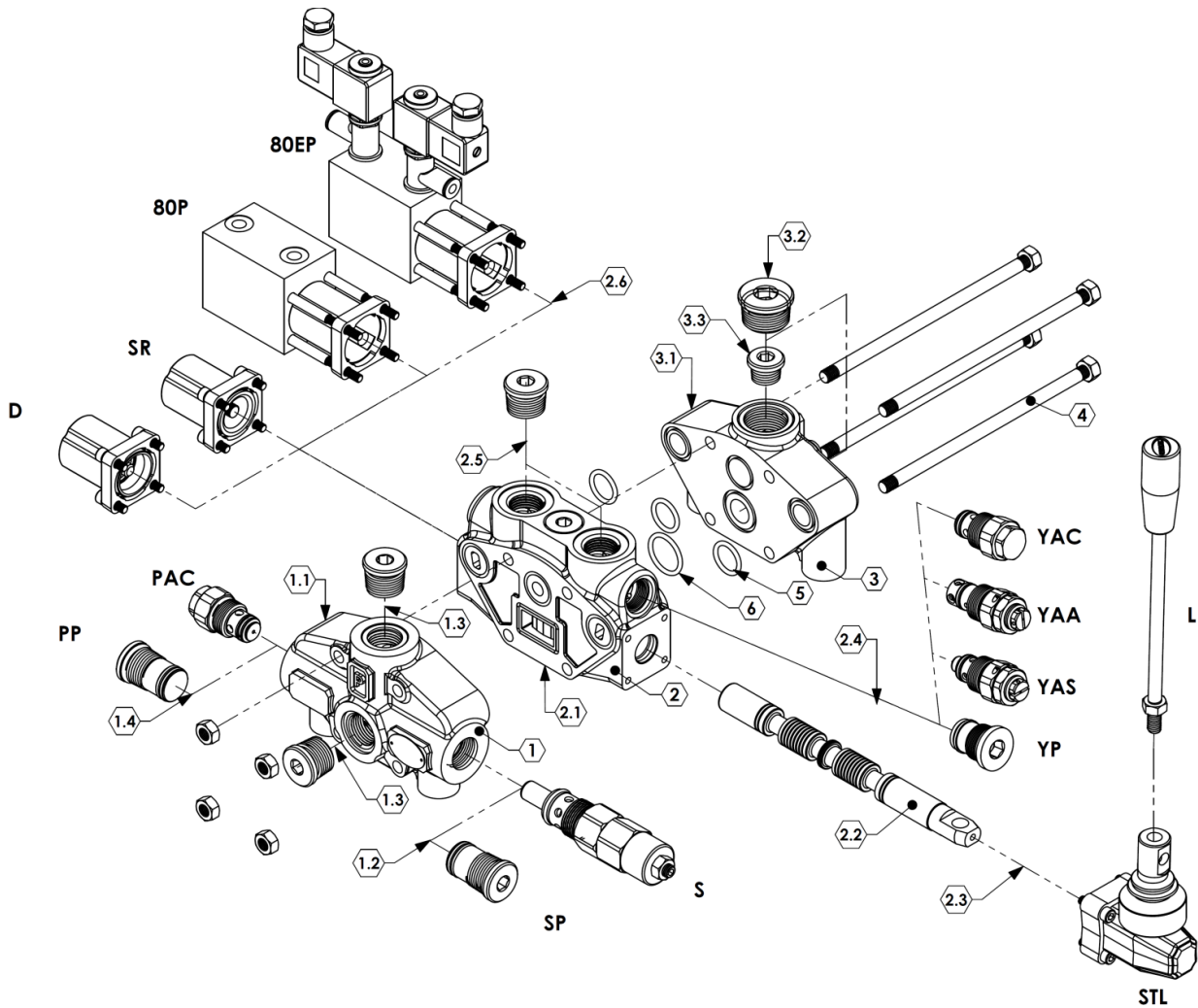
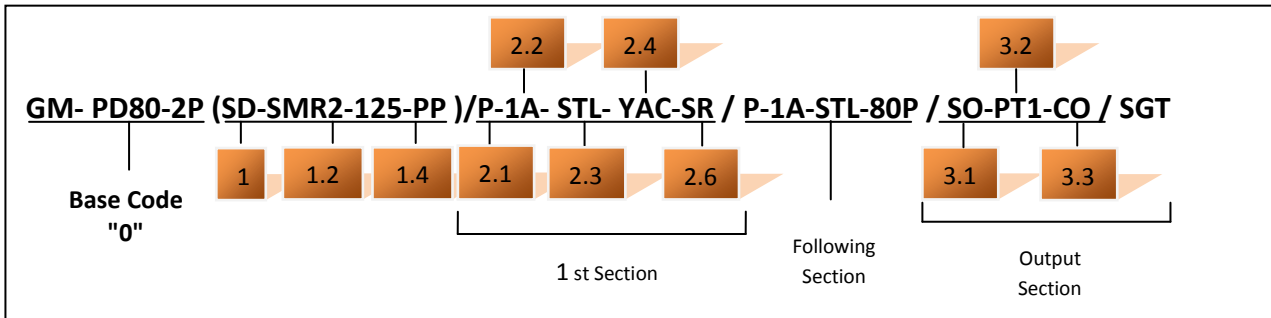

### 1-Inlet Section

**GM- PD80-2P** PD80 =Valve Type-(PD)- Sectional (80) - Max. Flow Rate  
 2P =Sections Quantity

**SD** = Side inlet with direct pressure relief valve (1SD80100)

**TD** = Top inlet with direct pressure relief valve (1TD80100)

**SP** = Side inlet with relief valve blanking plug (1SP80100)

### 2-Working Section

**P** = Parallel (2P80100)

### 3-Output Section

**SO** = Side outlet (3SO80100)

**TO** = Top outlet (3TO80100)

**TCO** = Top outlet with carry-over (3TCO80100)

**TC** = Top outlet with closed centre (3TC80100)

## Ordering Codes

### 4-Assembling Kit

Tie rod kit for 1 section valve	- (4TRK180100)
Tie rod kit for 2 section valve	- (4TRK280100)
Tie rod kit for 3 section valve	- (4TRK380100)
Tie rod kit for 4 section valve	- (4TRK480100)
Tie rod kit for 5 section valve	- (4TRK580100)
Tie rod kit for 6 section valve	- (4TRK680100)
Tie rod kit for 7 section valve	- (4TRK780100)
Tie rod kit for 8 section valve	- (4TRK880100)
Tie rod kit for 9 section valve	- (4TRK980100)
Tie rod kit for 10 section valve	- (4TRK1080100)
Tie rod kit for 11 section valve	- (4TRK1180100)
Tie rod kit for 12 section valve	- (4TRK1280100)

### 5-6-O\_Ring Kit

5. -17.00x2.65 NBR 70 SH O-Ring seal (3 Qty.)	(5MK80100)
6. -22.40x2.65 NBR 70 SH O-Ring seal (1 Qty.)	(6MK80100)

### 1.\*-Inlet Options

#### 1.1 Inlet Cover

Body = Standard (11BS80100)

#### 1.2 Inlet Relief

SMR1-080 – (12SMR180080)–Range 63-125 bar  
Setting 80 bar

SMR2-125 – (12SMR280125)–Range 100-160 bar  
Setting 125 bar

SMR3-175 – (12SMR380175)–Range 125-250 bar  
Setting 175 bar

SMR4-220 – (12SMR480220)–Range 200-315 bar  
Setting 220 bar

#### 1.3 Ports Plug

PA1 =G3/4 Top and side input - (13PA080100)

PA2= G1 Top and side input –(13PA280100)

#### 1.4 Inlet Valve

PAC = Inlet anti-cavitation valve –(14PAC80100)

PP(SP) = Relief valve blanking plug –(14PSP80100)

### 3.\*- Working Options

#### 3.1 Working Section

Body = Standard (31BS80100)

#### 3.2 Output Plug

PT1 =G1 Top and Side output (32PT180100)

#### 3.3 Circuits Options

CO =G1/8 Carry–Over Connector (33CO80100)

### 2.\*- Working Options

#### 2.1 Working Section

PA= Without ports valve prearrangement, with parallel circuit - Body (21BSPA80100)

#### 2.2 Spool Options

1A -(22SS80110) – 3 Positions ,Double acting

2A -(22SS80120) – 3 Positions ,Double acting  
A to tank B Blocked

3A -(22SS80130) – 3 Positions ,Double acting  
B to tank A blocked

4A -(22SS80140) – 3 Positions ,Double acting  
A and B tank

5A -(22SS80150) – 3 Positions ,Single acting on  
A (A to tank)

6A -(22SS80160) – 3 Positions ,Single acting on  
B (B to tank)

#### 2.3 Lever Options

L =Standard HandLever (L=120mmxM8) -  
(7L040100)

STL=Standard Lever –(23STL80100)

#### 2.4 Port Relief Valves

##### Anti-Shock Valve

YAC (T1-50) – (24YAC80050)–Range 35-70 bar  
Setting 50 bar

YAC (T1-100) – (24YAC80100)–Range 63-220 bar  
Setting 100 bar

YAC (T1-200) – (24YAC80200)–Range 180-350 bar  
Setting 200 bar

##### Anti-Shock and Anti-Cavitation Valve

YAA (T1-63) – (24YAA80063)–Range 35-70 bar  
Setting 50 bar

YAA (T1-100) – (24YAA80063)–Range 63-220 bar  
Setting 100 bar

YAA (T1-200) – (24YAA80063)–Range 180-350 bar  
Setting 200 bar

YAS - Anti Cavitation– (24YAS80100)

YP- A and B ports valve blanking plug (24YP80100)

DST-A and B ports valve blanking plugs with  
connection to tank–(24DST80100)

#### 2.5 Ports Plug Options

PL1 =Plug for single action spool for 2A-3A, G3/4  
(25PL180100)

PL2 =Plug for single action spool for 2A-3A, G1  
(25PL280100)

#### 2.6 Spool Positioners

SR=Spring Return in neutral position – (26SR80100)

D =Detent in position 1, neutral and 2 -(26D80100)

80P=ON/OFF Pneumatic – (2645P150100)

80EP=12 VDC ON/OFF electro-pneumatic –

(2680EP150112)

24 VDC ON/OFF electro-pneumatic –

(2680EP150124)

Inlet Cover- Pump Side

LH Inlet Valve Options

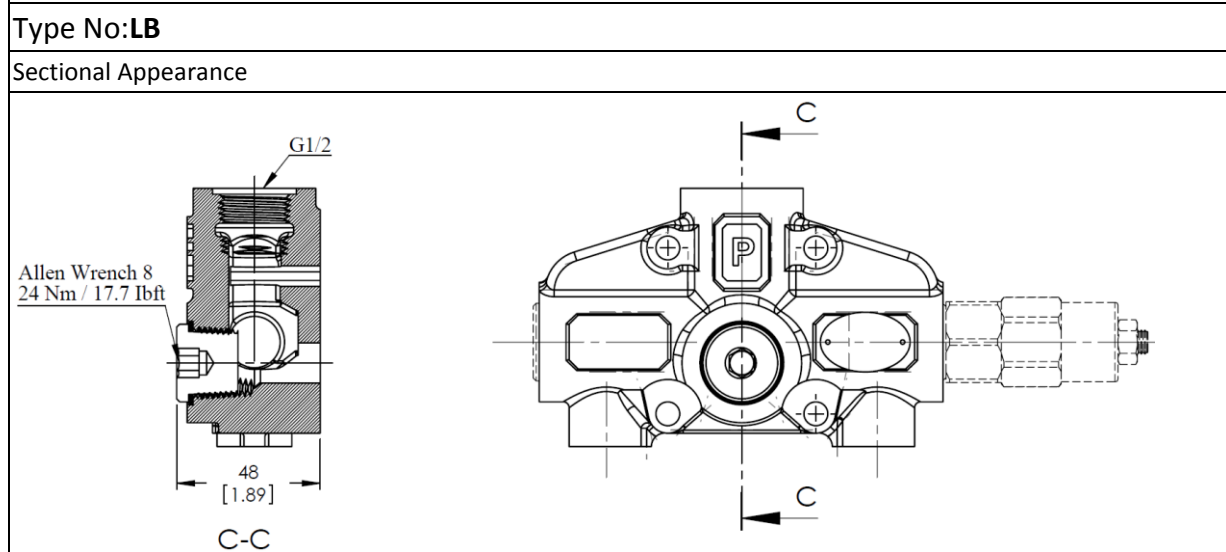
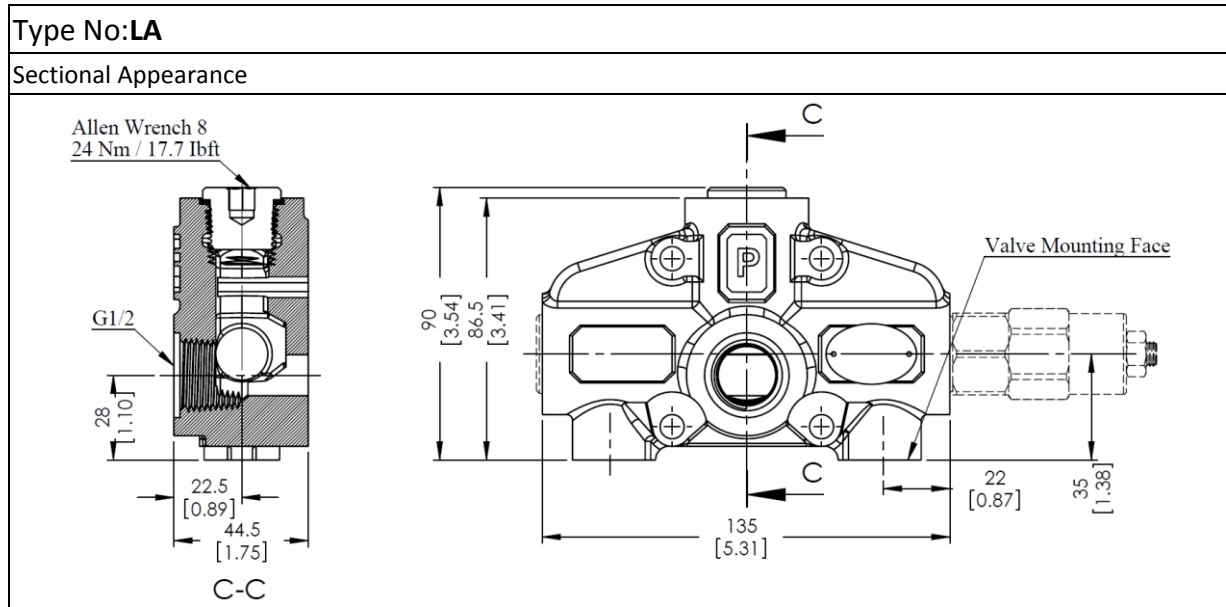

Hydraulic Diagram

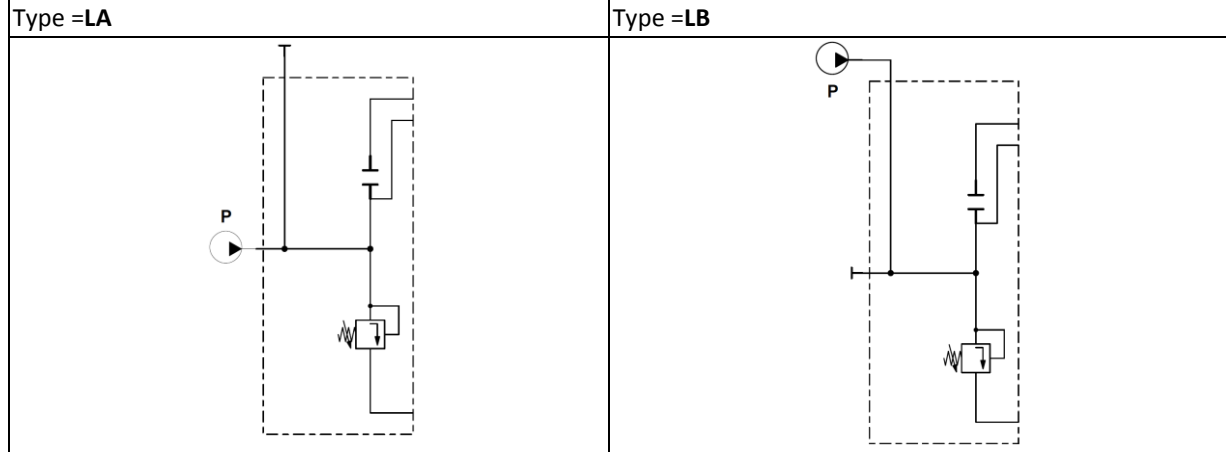



**Inlet Cover- Pump Side**

**RH Inlet Valve Options**

Type No:RA  
Sectional Appearance

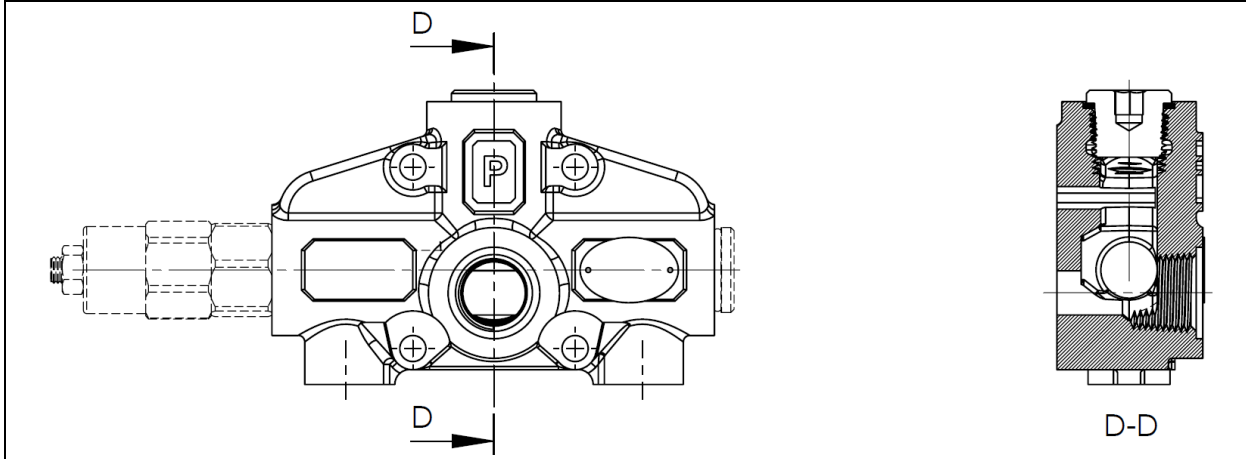

Type No:RB  
Sectional Appearance

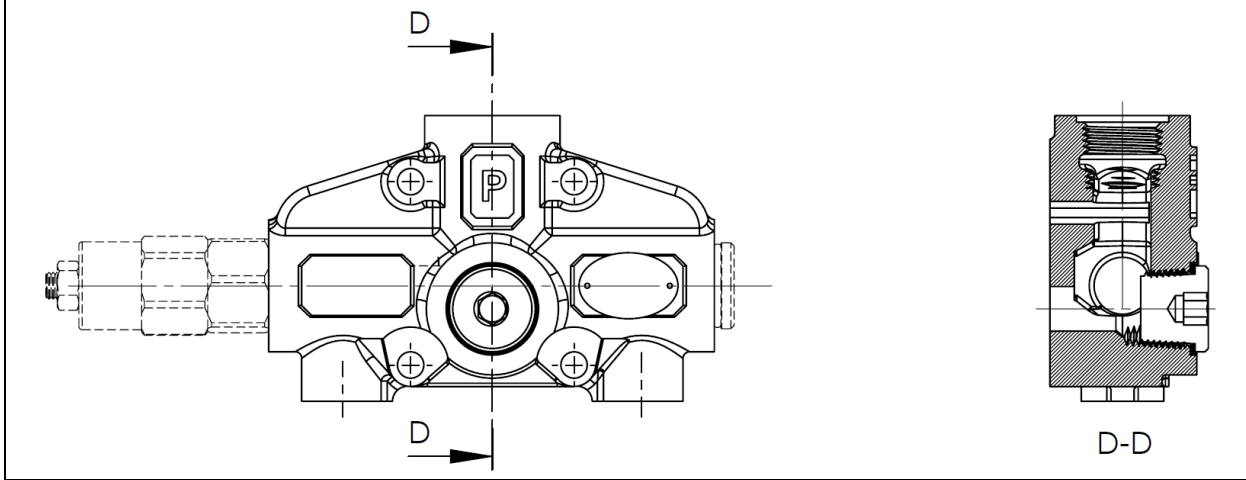

**Hydraulic Diagram**

Type =RA

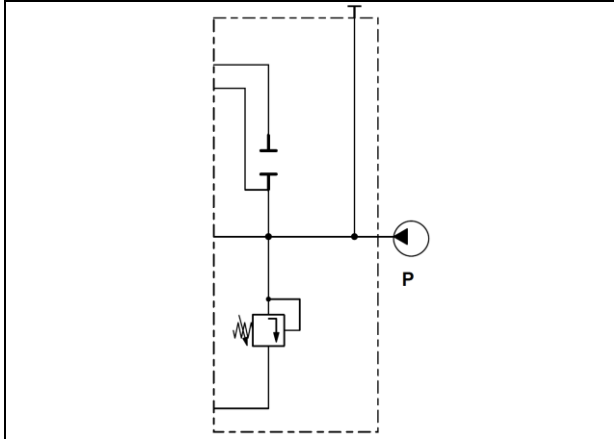

Type =RB

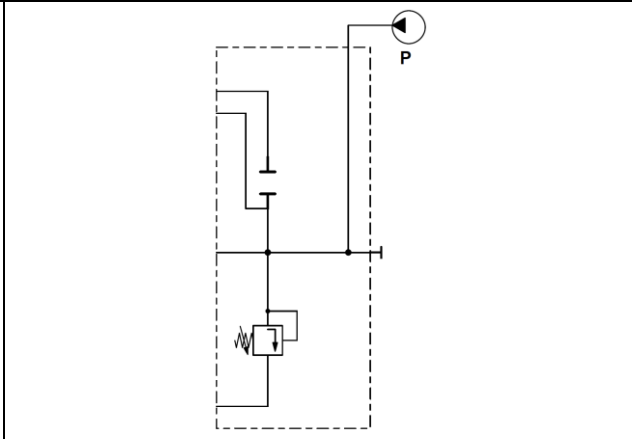

## Spool Options

### Spool Type - 1A

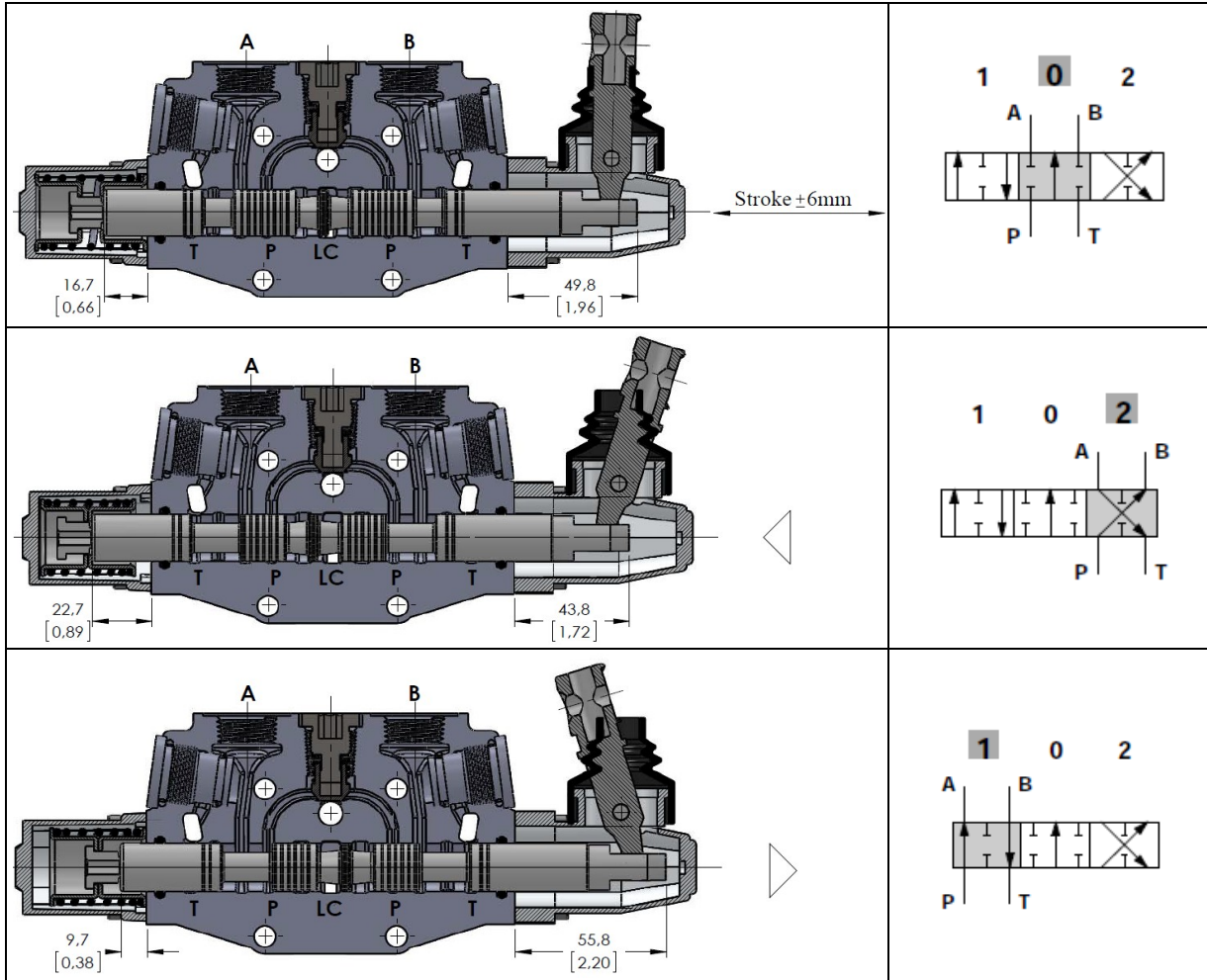

### Performance Curve And Data:

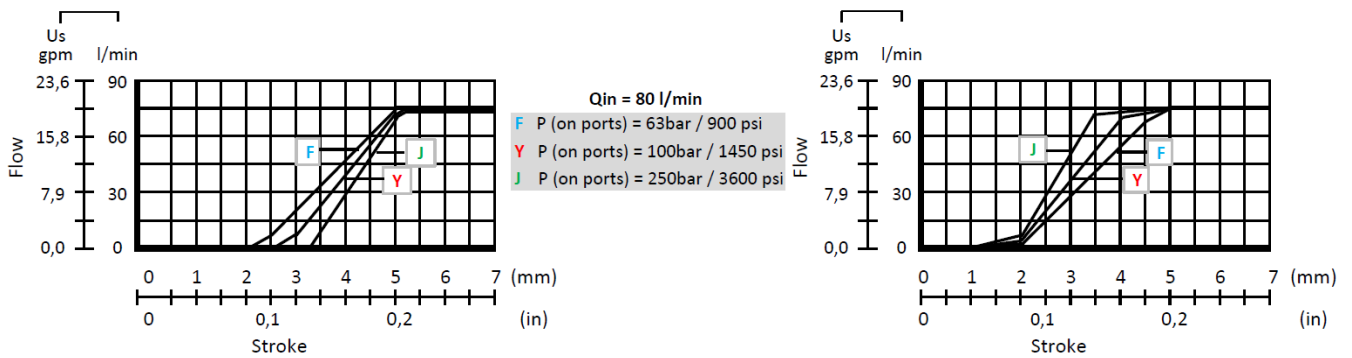

Spool Options

Spool Type - 2A

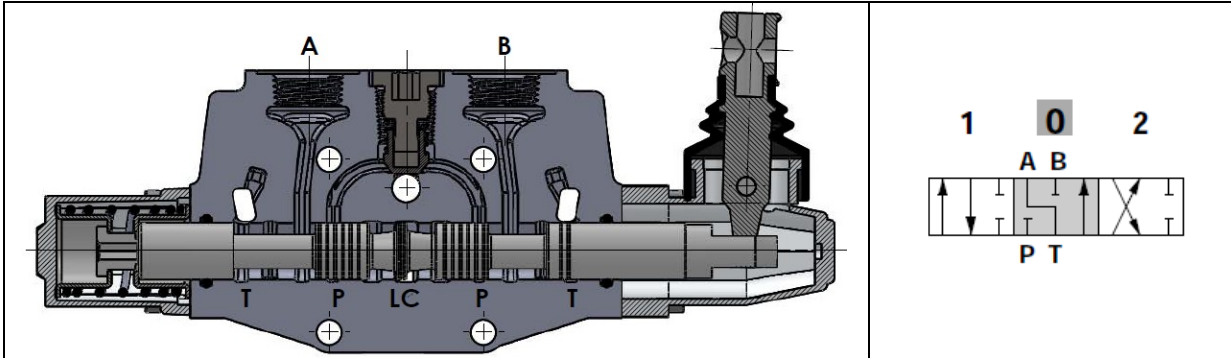

Spool Type - 3A

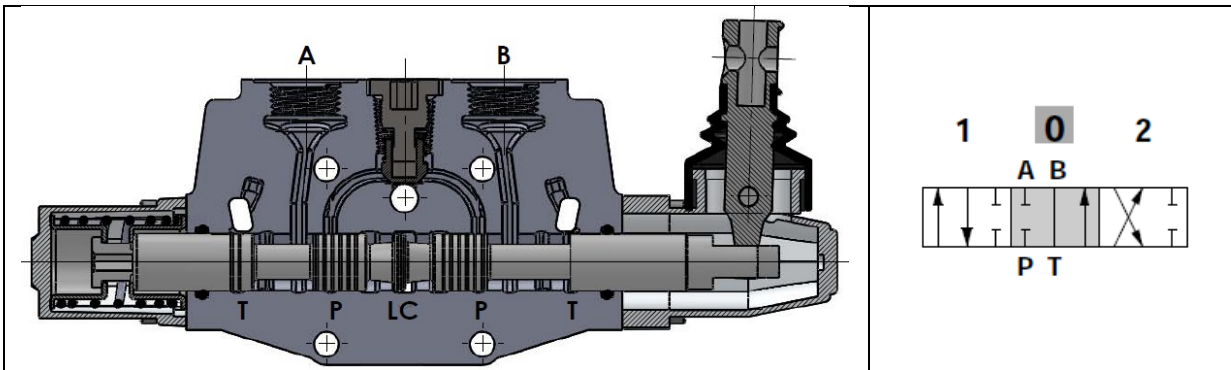

Spool Type - 4A

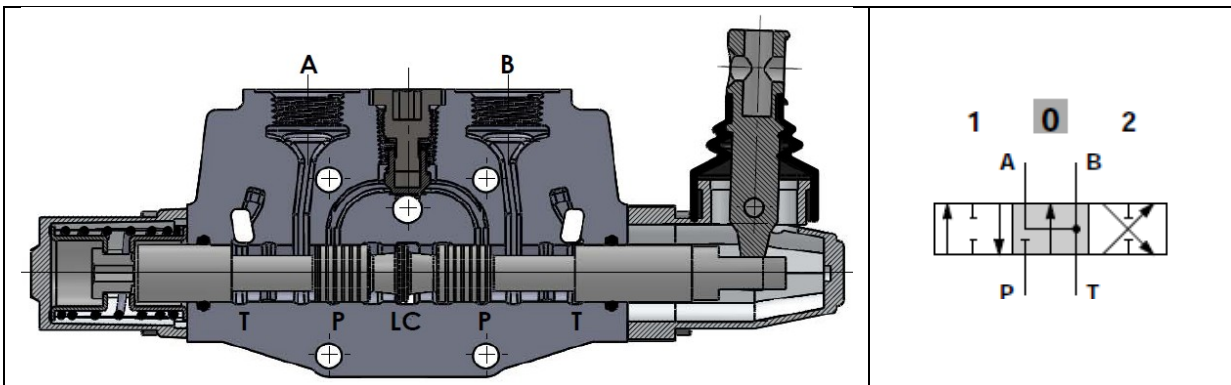

Spool Options

Spool Type - 5A

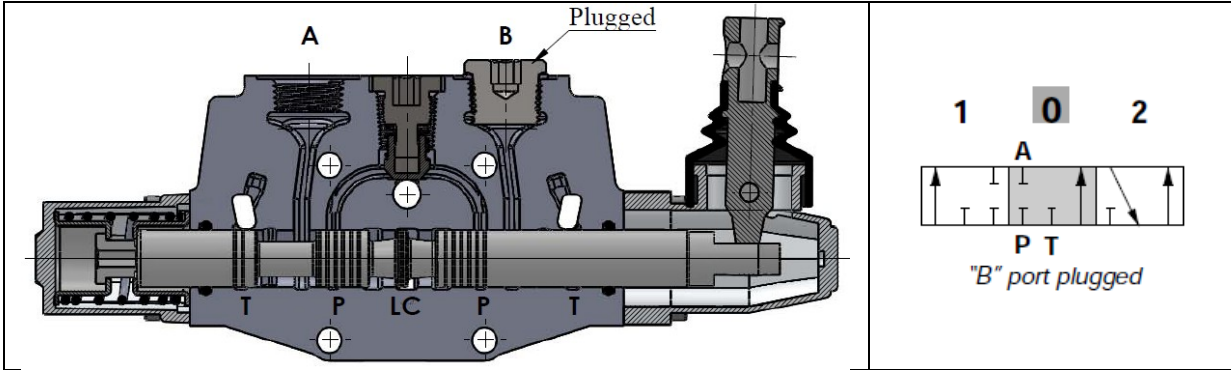

Spool Type - 6A

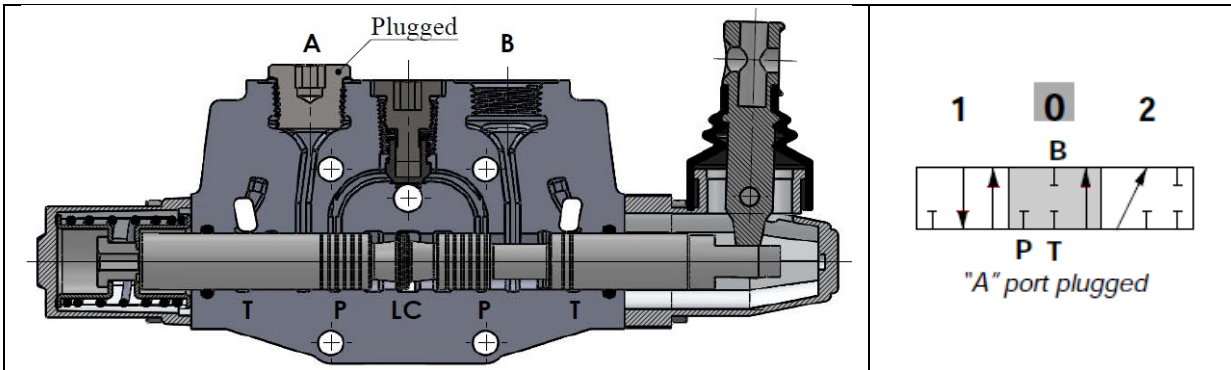

Spool Positioners – Side of Return

With Spring Return in Neutral Position

Kit No:SR	
Sectional Appearance	Diagram

With Detent

Kit No:D	
Sectional Appearance	Diagram

Force - stroke diagram

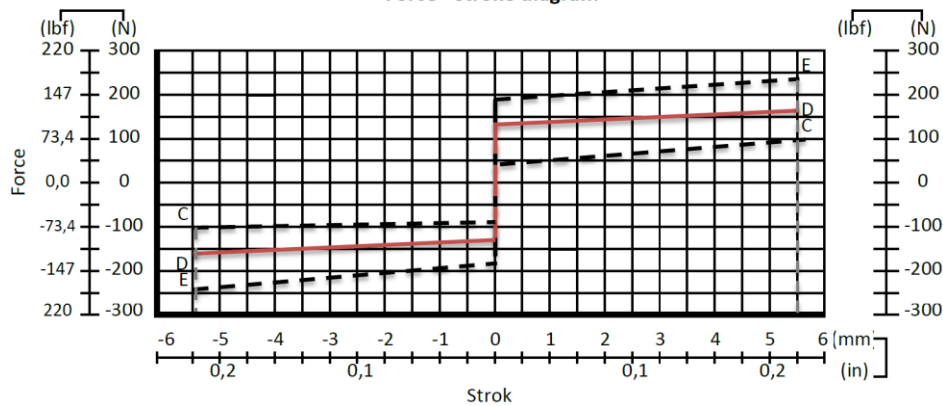



## Spool Positioners – Side of Return

### ON/OFF Pneumatic Control

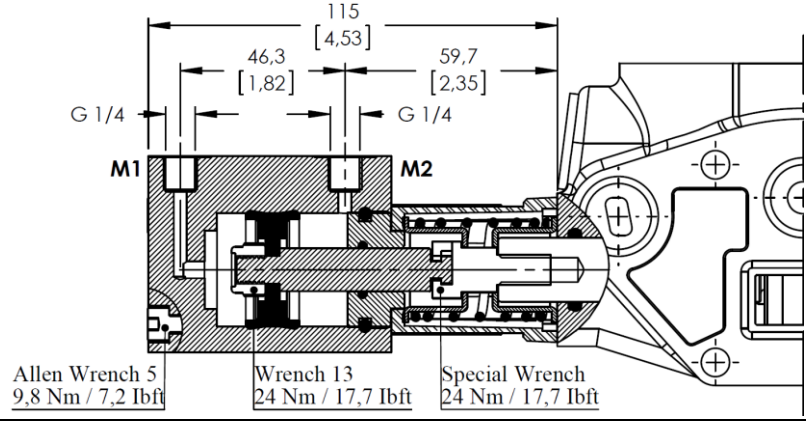
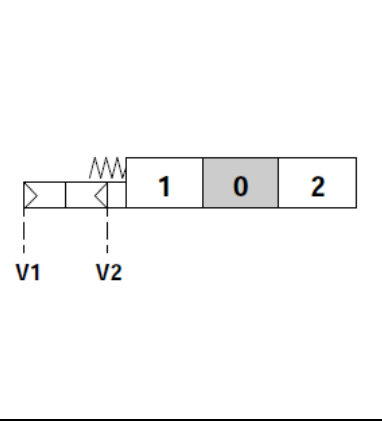
<b>Kit No:80P</b>	
<b>Sectional Appearance</b>	<b>Diagram</b>
 <p>Allen Wrench 5 9,8 Nm / 7,2 Ibft</p> <p>Wrench 13 24 Nm / 17,7 Ibft</p> <p>Special Wrench 24 Nm / 17,7 Ibft</p>	
<b>Operatig Features</b> Pilot Pressure .....: 6 Bar (Max. 10) / 87 Psi (Max. 145)	

### ON/OFF Electro-Pneumatic Control

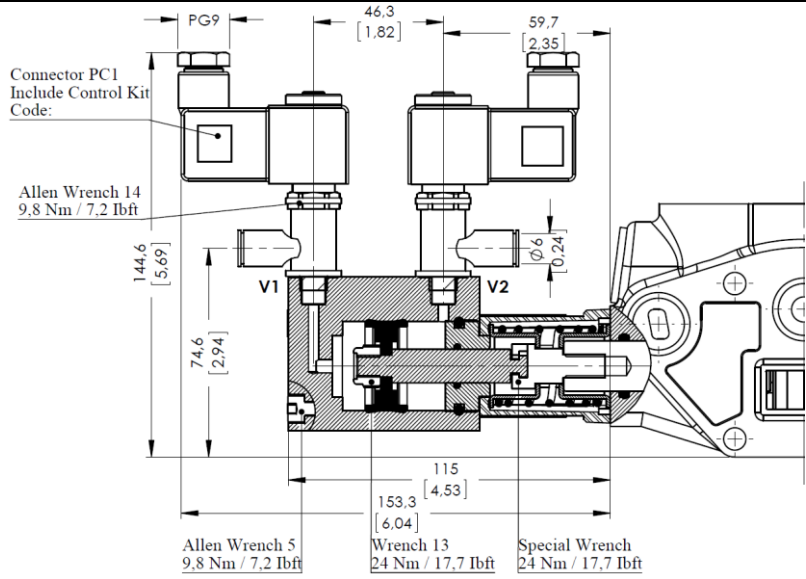
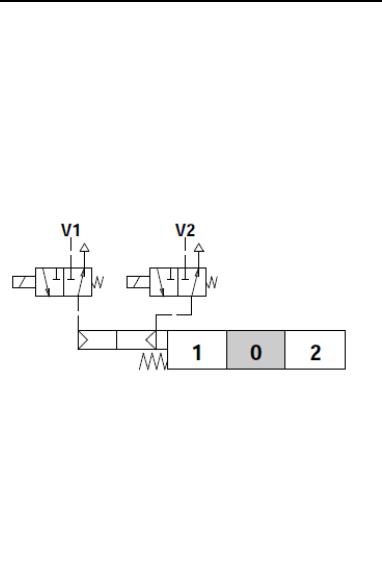
<b>Kit No:80EP</b>	
<b>Sectional Appearance</b>	<b>Diagram</b>
 <p>Connector PC1 Include Control Kit Code:</p> <p>Allen Wrench 14 9,8 Nm / 7,2 Ibft</p> <p>Allen Wrench 5 9,8 Nm / 7,2 Ibft</p> <p>Wrench 13 24 Nm / 17,7 Ibft</p> <p>Special Wrench 24 Nm / 17,7 Ibft</p>	
<b>Operatig Features</b> Pilot Pressure .....: 6 Bar (Max. 10) / 87 Psi (Max. 145)	
<b>Selonoid Operating Features</b> Nominal Voltage.....: 12VDC / 24 VDC Power Rating.....: 6 W	

**Working Section Kit**

**With Port Valves Type**

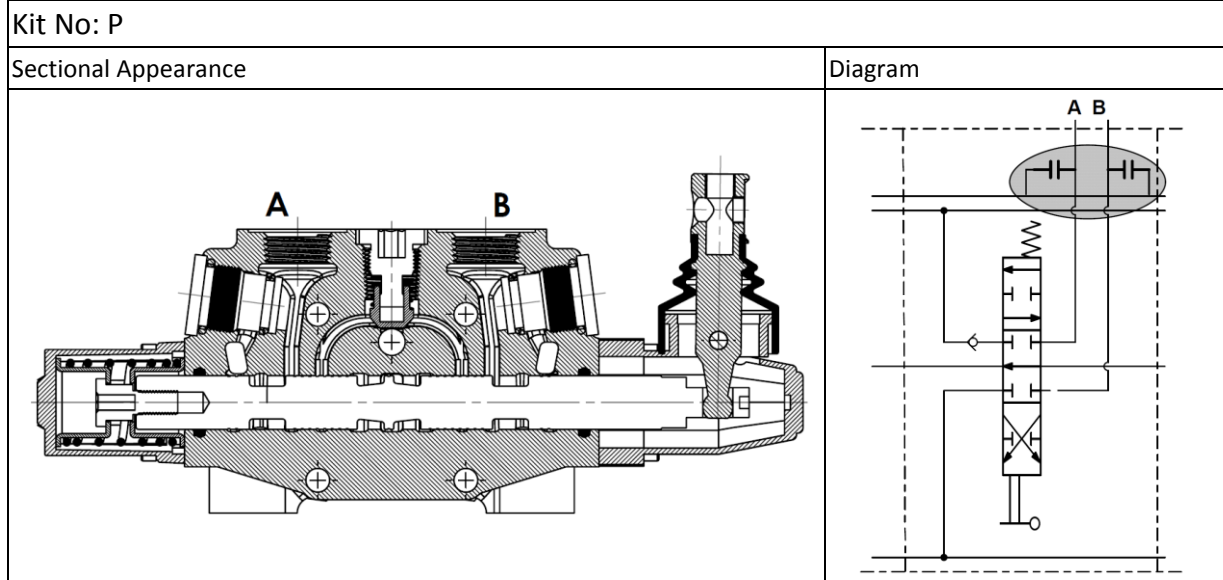

**Without Port Valves Type**

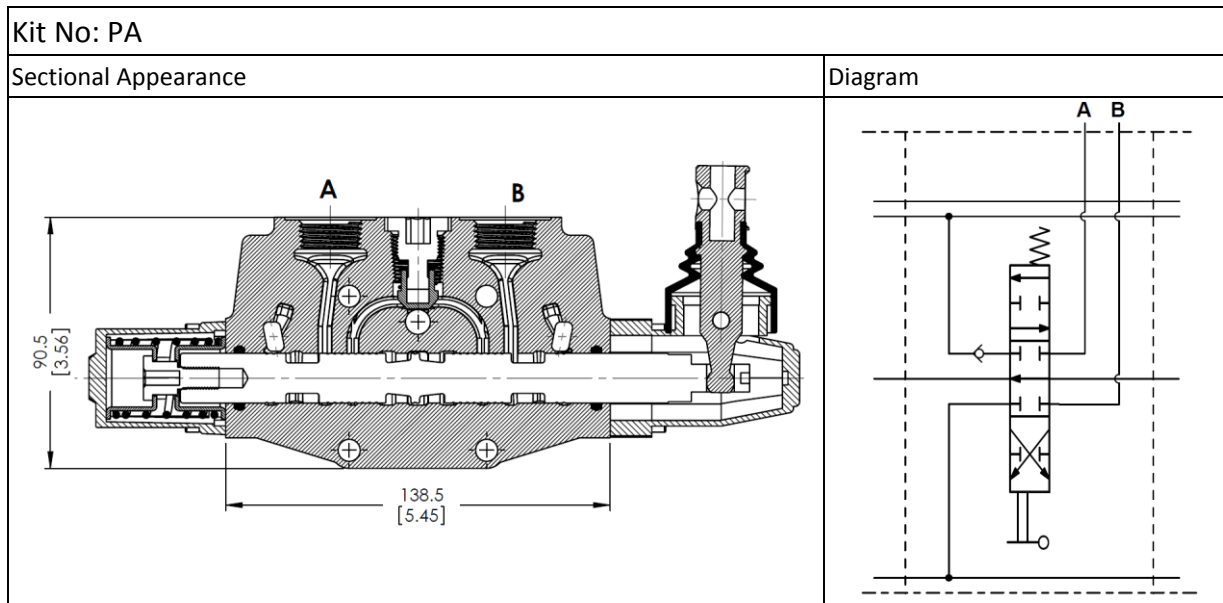

Spool Positioners – Side of Lever Control

Lever Controls

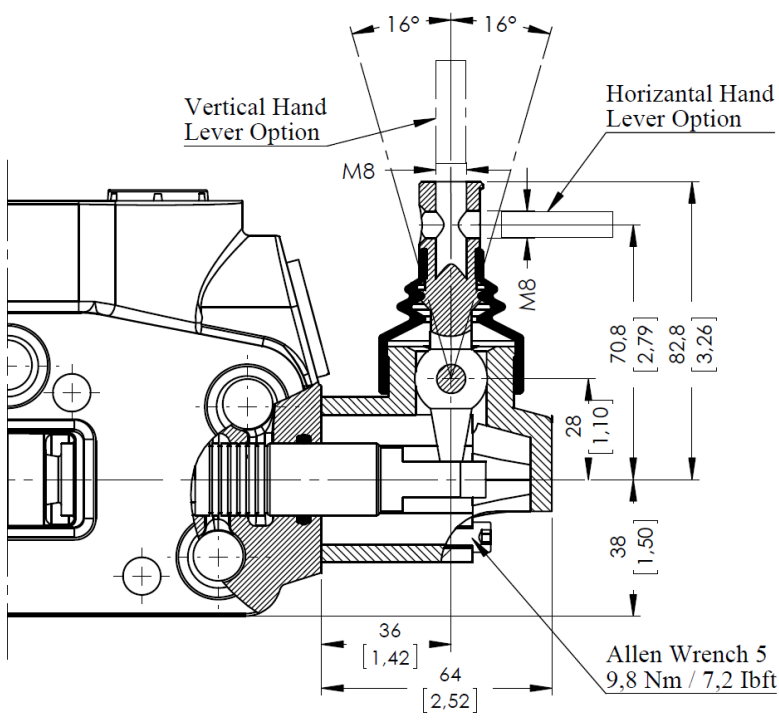
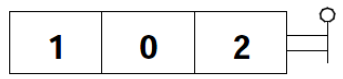
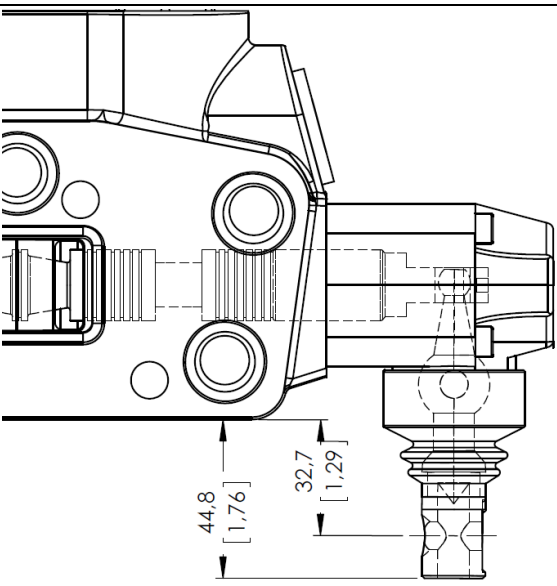
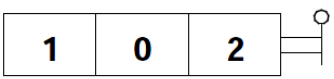
<p>Kit No: <b>STL - L0</b></p>	
<p>Sectional Appearance</p> 	<p>Diagram</p> 
<p>Kit No: <b>STL - L180</b></p>	
<p>Sectional Appearance</p> 	<p>Diagram</p> 
<p>Note: Alluminium with protection arm lever pivot box, it can be rotated 180°.</p>	

Outlet Cover- Tank Side

Output Cover Options

<p>Type No:TA</p> <p>Sectional Appearance</p>	
<p>Type No:TB</p> <p>Sectional Appearance</p>	
<p>Hydraulic Diagram</p>	
<p>Type = TA</p>	<p>Type=TB</p>

Outlet Cover- Tank Side

Output Cover Options

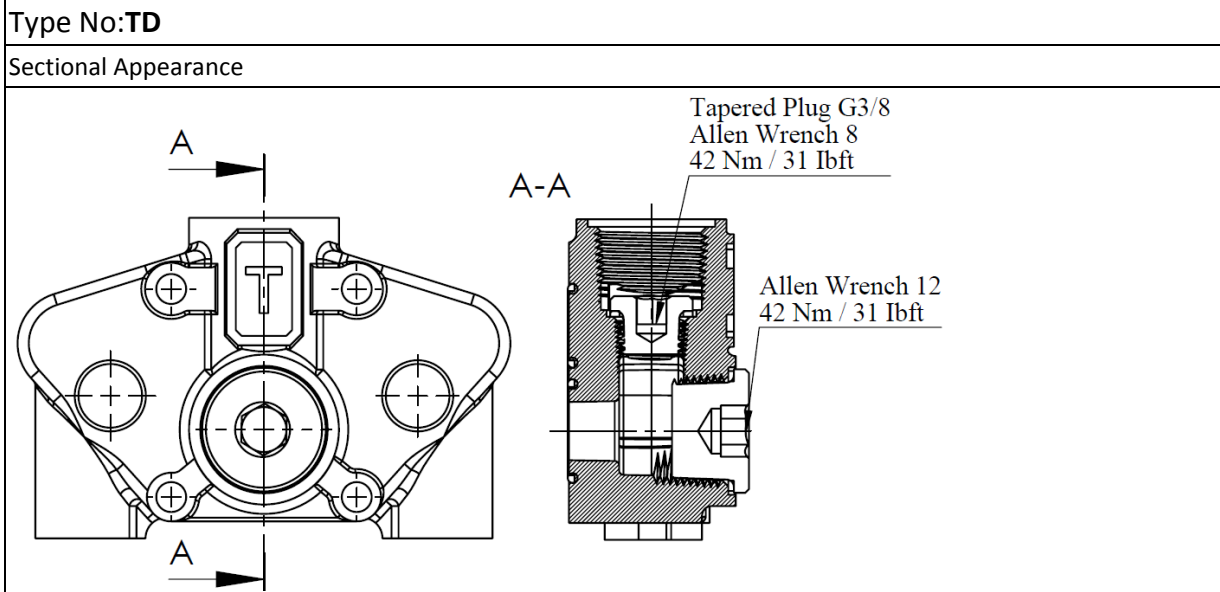
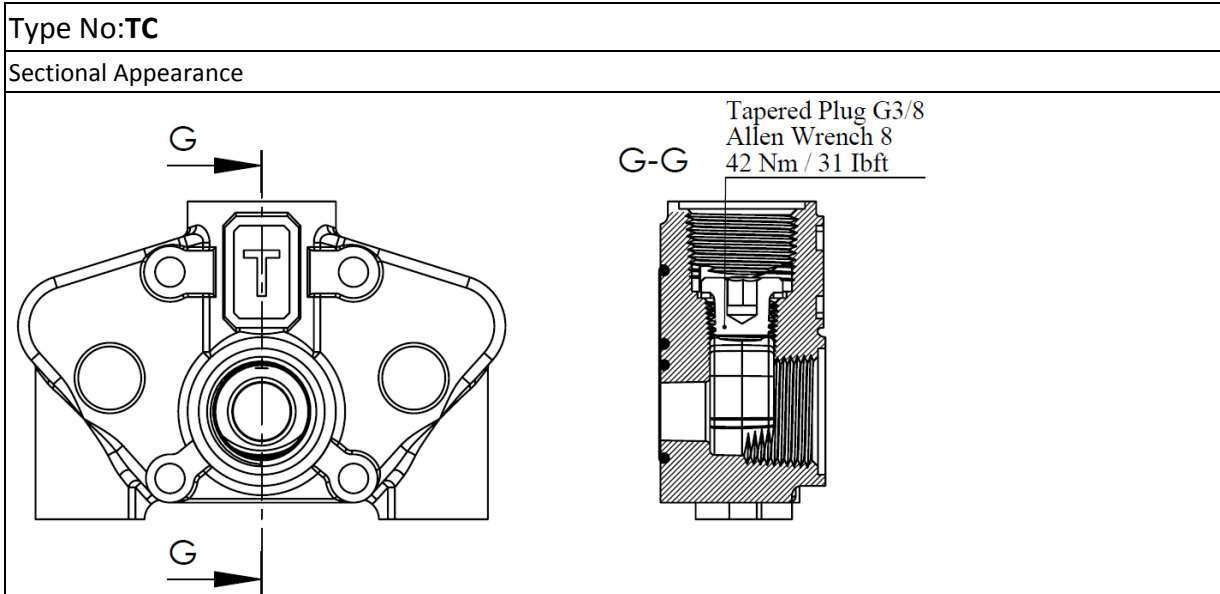

Hydraulic Diagram

Type = TC

Type=TD

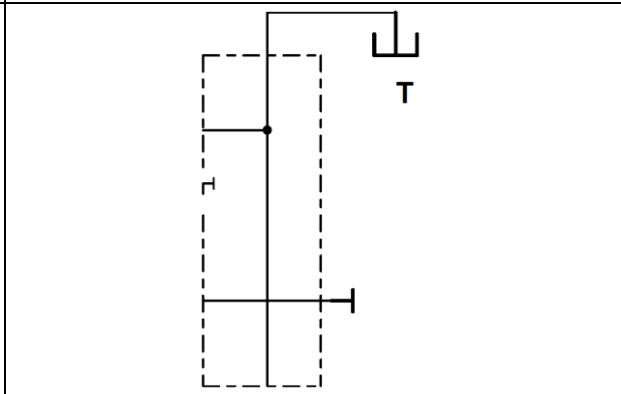
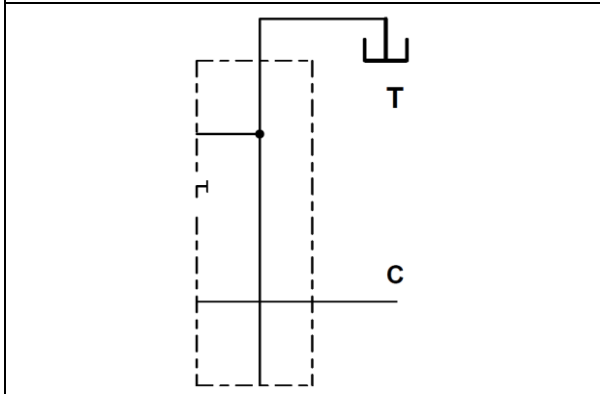



## Port Valves Options

### Anti Cavitation Valves

Code: \_\_\_\_\_ →

**YAC -1(T1-100)**

→ Pressure setting in bar.

→ Adjusting type T=With screw , L=Valve Set / Spring Type (1,2,3)

→ 1= Mounted Port A , 2=Mounted Port B , 3=Mounted Port A and B

### Hydraulic Diagram

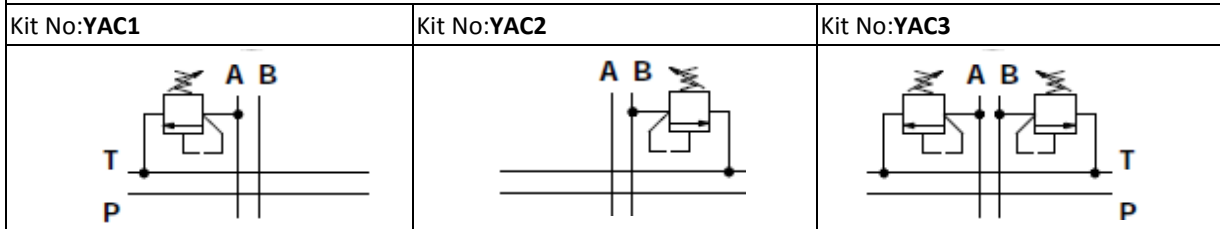

### Adjustment Type on Valve:

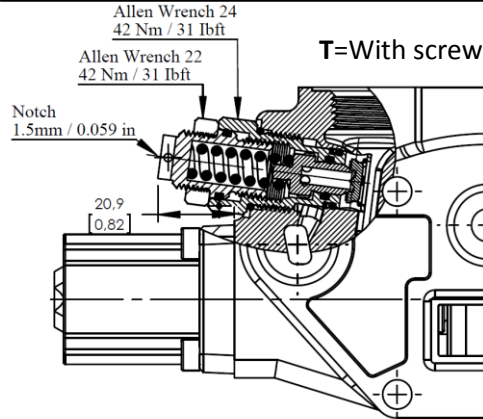

### L=Valve set

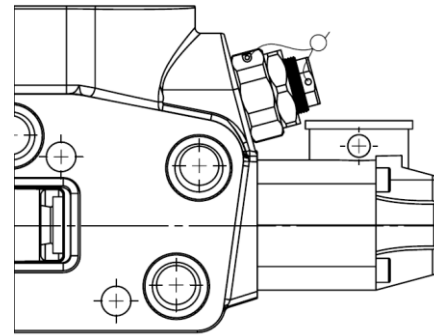

### Performance Data:

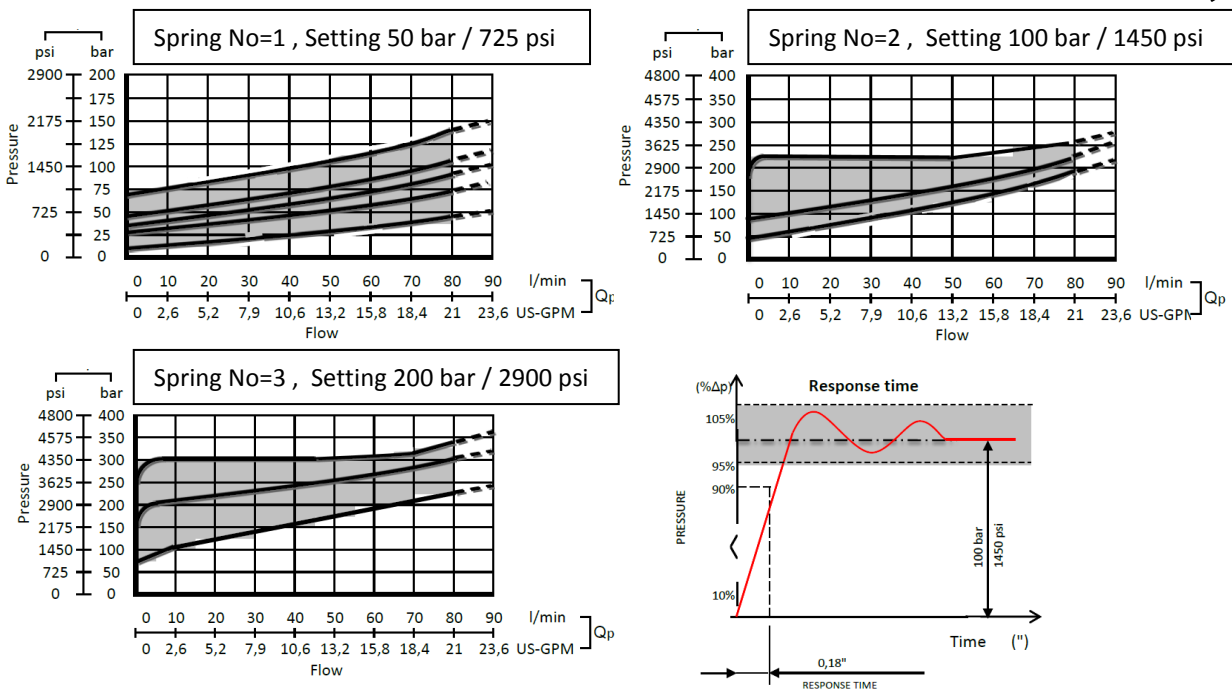

## Port Valves Options

### Anti shock And Anti Cavitation Valves

Code:

**YAA -1(T1-100)**

→ Pressure setting in bar.

→ Adjusting type T=With screw , L=Valve Set / Spring Type (1,2,3)

→ 1= Mounted Port A , 2=Mounted Port B , 3=Mounted Port A and B

#### Hydraulic Diagram

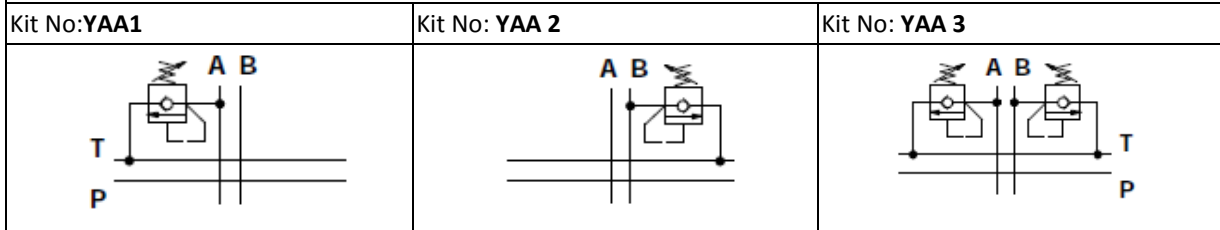

#### Adjustment Type on Valve:

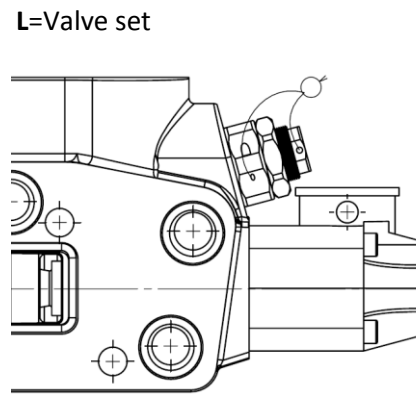
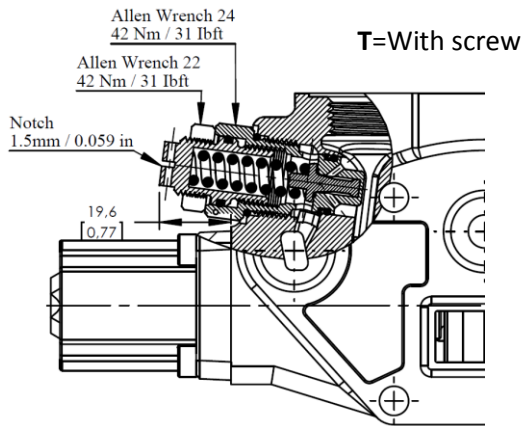

#### Performance Data:

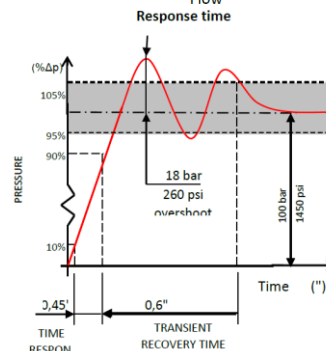
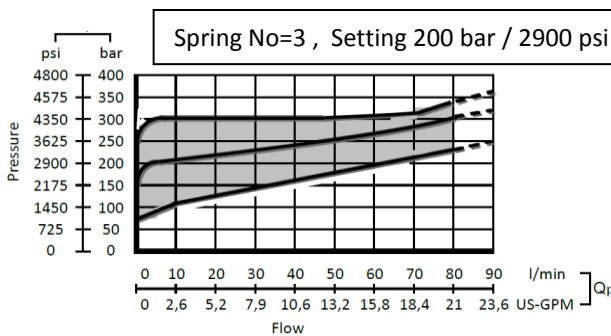
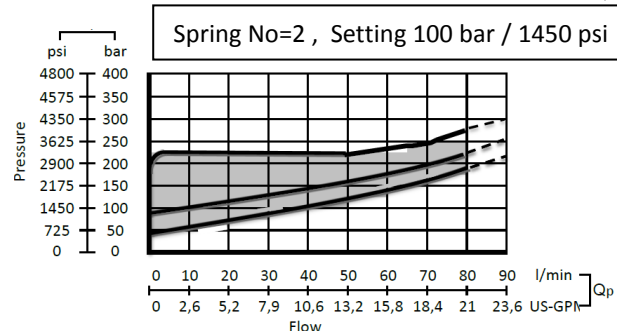
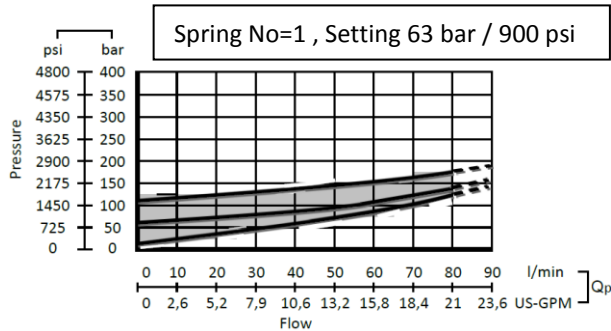

## Port Valves Options

### Anti shock Valves

Code: \_\_\_\_\_ →

**YAS – 1** → 1= Mounted Port A , 2=Mounted Port B , 3=Mounted Port A and B

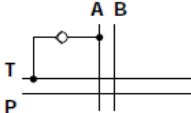
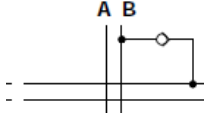
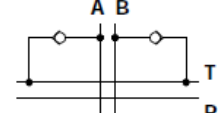
Hydraulic Diagram		
Kit No: YAS1	Kit No: YAS 2	Kit No: YAS 3
		

Adjustment Type on Valve And Data: \_\_\_\_\_ →

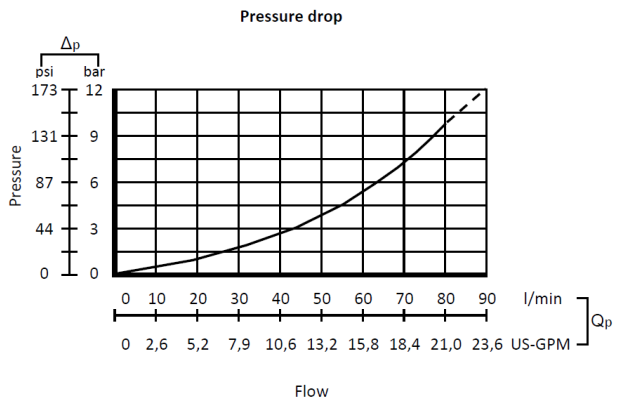
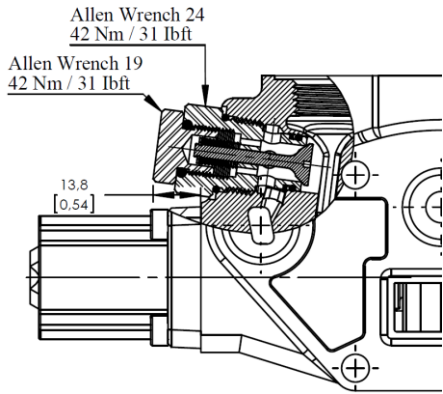

### Valve Blaking

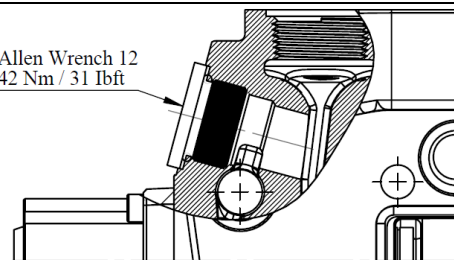
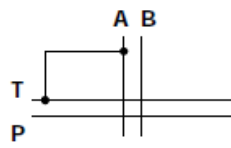
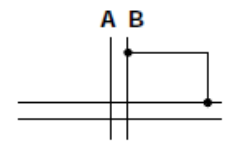
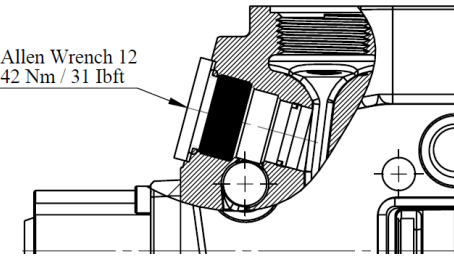
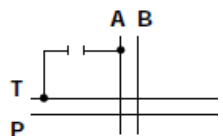
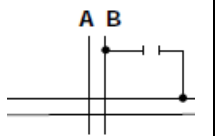
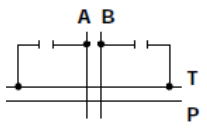
Plug with tank connection			
<b>DST-1</b> (1:Mounted port A – 2:Mounted port B)			
Sectional Appearance	Hydraulic Diagram		
	<b>DST1</b> 	<b>DST2</b> 	
Plug			
<b>YP-1</b> (1:Mounted port A – 2:Mounted port B – 3:Mounted port A and B)			
	<b>YP1</b> 	<b>YP2</b> 	<b>YP3</b> 

## Installation and Maintenance

The GM-PD80 valve is assembled and tested as per the technical specification of this catalog.

Before the final installation on your equipment, follow the below recommendation:

- The valve can be assembled in any position, in order to prevent body deformation and spool sticking mount the product on a flat surface;
- In order to prevent the possibility of water entering the lever box and spool control kit, do not use high pressure wash down directly on the valve;
- Prior to painting, ensure plastic port plugs are tightly in place.

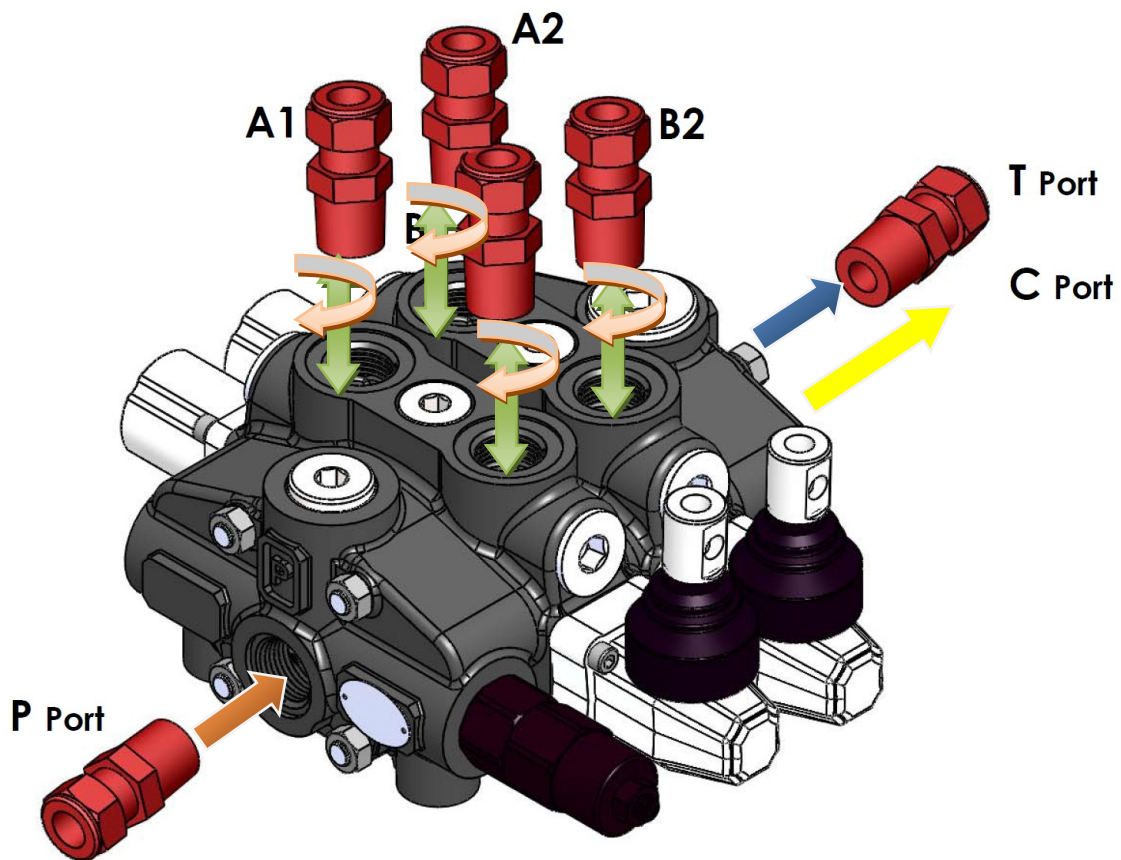

Therads Type	P Port	A and B Port	T Port
BSP (ISO 228/1)	G 1/2	G 1/2	G 3/4
With O-Ring seal	50 / 36.9	50 / 36.9	70 / 51.6
With copper washer	60 / 44.3	60 / 44.3	70 / 51.6
With steel and rubber washer	60 / 44.3	60 / 44.3	70 / 51.6
BSP (ISO 228/1)	G 3/4	G 3/4	G 3/4
With O-Ring seal	70 / 51.6	70 / 51.6	70 / 51.6
With copper washer	70 / 51.6	70 / 51.6	70 / 51.6
With steel and rubber washer	70 / 51.6	70 / 51.6	70 / 51.6
UN--UNF (ISO 11926--1)	11/16--12 UNF--2B	9/16--18 UNF--2B	11/16--12 UNF--2B
With O-Ring seal	95 / 70	30 / 22.1	95 / 70
METRIC (ISO 262)	M27 x 2	M22 x 1.5	M27 x 2
With O-Ring seal	100 / 73.8	50 / 36.9	100 / 73.8
With copper washer	100 / 73.8	60 / 44.3	100 / 73.8
With steel and rubber washer	100 / 73.8	60 / 44.3	100 / 73.8

## Technical Data

### Ports Dimensional Data

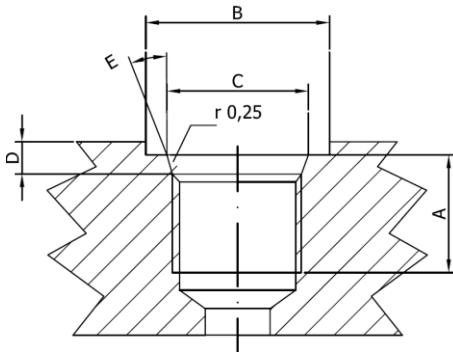

SAE UN-UNF (ISO 725)							
Dimensions		7/8-14 UNF SAE10		1"1/16-12 UN SAE12		1"5/16-12 UN SAE16	
mm	in						
A		17	0,67	20	0,79	20	0,79
B		34	1,34	41	1,61	49	1,92
C		23,9	0,94	29,2	1,15	35,5	1,40
D		2,5	0,10	3,3	0,13	3,3	0,13
E		15°		15°		15°	

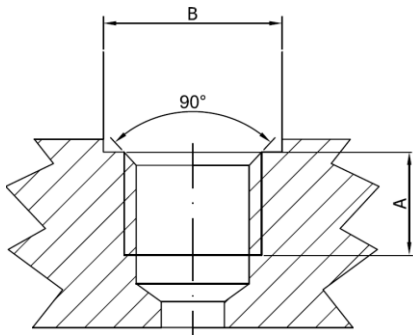

BSP (ISO 228)							
Dimensions		G 1/2"		G 3/4		G 1	
mm	in						
A		16	0,63	18	0,71	20	0,79
B		27	1,06	33	1,30	40	1,57

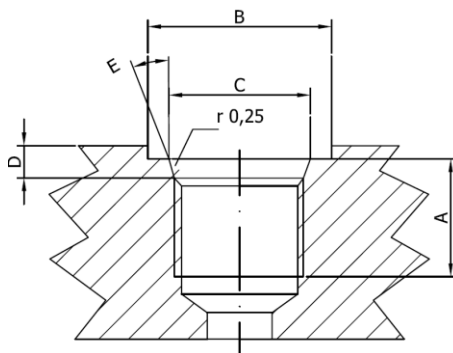

METRIC (ISO 262)							
Dimensions		M22x1,5 ISO 262		M27x2 ISO 262			
mm	in						
A		16	0,63	18	0,71		
B		31,5	1,24	37,7	1,48		