

Sandwich valves provide a variety of check, flow control, pressure relief and pressure reducing functions in a compact NFPA D03, D05, D07 and D08 sandwich style valve. The NFPA D03 valve body conforms to the ISO 40 mm (1.57") thickness. These valves are mounted between directional control valves and their mounting surface.

The NFPA D03 Sandwich valves may also be used in conjunction with Parker's Cartpak Series of sandwich valves which offer a wide variety of additional functions including relief, pressure reducing/relieving, load check, back pressure check, needle, flow control, pressure compensated flow control, crossover, relief and directional valves.

B

Check Valves

Series CM, ZRV

- Valve bodies are manufactured from steel which provide extra strength and durability for longer life. Internal hardened steel components also provide longer life.
- Positive shut-off is provided by a fully guided poppet and allows full flow in the unchecked position.
- Parker CM, ZRV sandwich style check valves can be used either on the 'P', 'A', 'B', 'T' port or combination.
- Large internal flow paths allow high flow at low pressure drop.

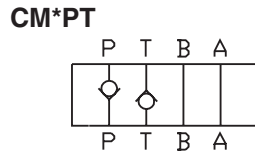
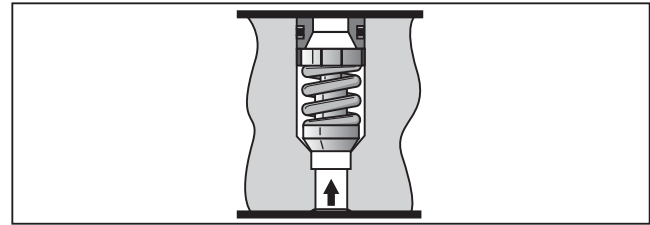

CM*AA

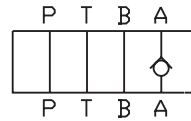

CM*AAF

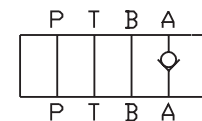

CM*BB

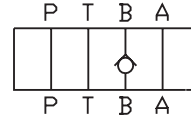

CM*BBF

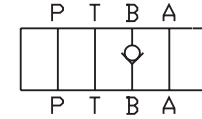

CM*DD

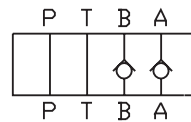

CM*DDF

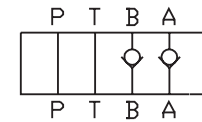

CM*PP, ZRV-P

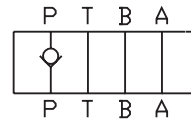

CM*TT, ZRV-T

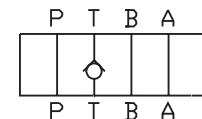

P.O. Check Valves

Series CPOM, ZRE

- Parker CPOM, ZRE sandwich style, pilot operated check valves can be provided in either single or double configurations.
- The pilot operated checks may be positioned in 'A' port or 'B' port; or both 'A' and 'B' ports.
- Valve bodies are manufactured from steel which provide extra strength and durability for longer life. Internal hardened steel components also provide longer life.
- Large internal flow paths allow high flow at low pressure drop.

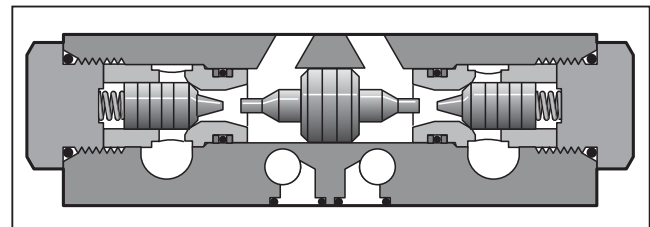

CPOM*AA, ZRE-A

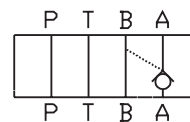

CPOM*BB, ZRE-B

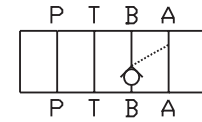

CPOM*DD, ZRE-AB

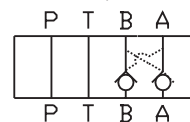

Flow Control Valves

Series FM, ZRD

- Parker FM, ZRD sandwich style flow control valves can be provided in either single or double configurations.

The flow controls may be positioned in 'P' port, 'A' port, 'B' port, or both 'A' and 'B' ports.

- Valve bodies are manufactured from steel which provide extra strength and durability for longer life. Internal hardened steel components also provide longer life.
- Two step needles (standard) provide fine adjustment for the first three turns and course adjustment for the last three turns. Fine metering needles are available as an option on D03 and D05 valves.
- Large bypass checks allow high flow at a low pressure drop.
- Reversible (invert 180°) for meter-in or meter-out (D03 & D05 only).

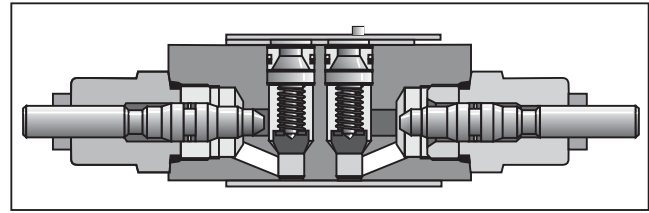

FM*AA, ZRD-AA

(Meter Out)

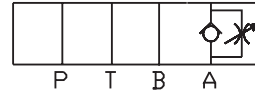

FM*BB, ZRD-BA

(Meter Out)

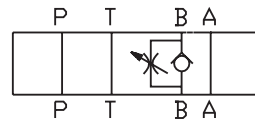

FM*DD, ZRD-ABA

(Meter Out)

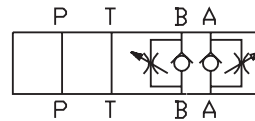

FM*PP

(Meter Out)

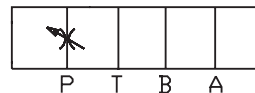

Pressure Reducing Valves

Series PRDM

- PRDM sandwich valves may be selected to reduce pressure in the 'P' port, 'A' port or 'B' port.
- The direct operated, cushioned piston design results in fast response, low leakage and minimal hysteresis.
- Up to nine pressure adjustment ranges are available with maximum pressure settings.
- Adjustment options include: internal hex screw, hand knob or internal hex with keylock.
- Fluorocarbon and nitrile seals are available for multi-fluid compatibility.
- Available gage port connections include SAE, NPT, Metric and BSPP.

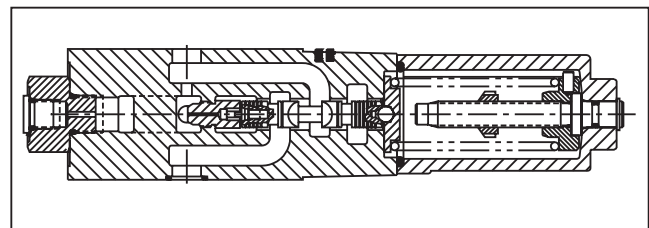

PRDM*PP

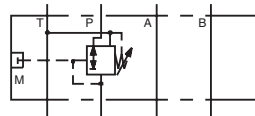

PRDM*AA

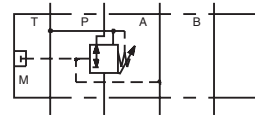

PRDM*BB

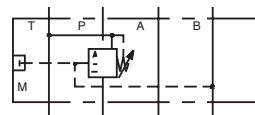

Pressure Reducing Valves

Series PRM, ZDR

- Parker PRM, ZDR sandwich style pressure reducing valves can be used to reduce pressure on the 'P' port, the 'A' port, or the 'B' port.
- Three pressure adjustment options available: slotted screw, knob and locking knob.
- Valve bodies are manufactured from steel which provide extra strength and durability for longer life. Internal hardened steel components also provide longer life.

B

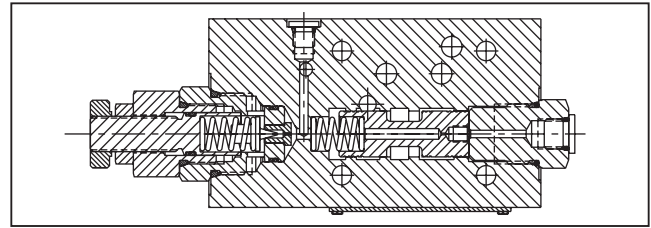

PRM*AA, ZDR-A

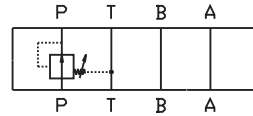

PRM*BB, ZDR-B

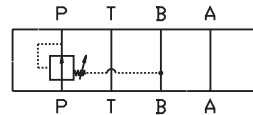

PRM*PP, ZDR-P

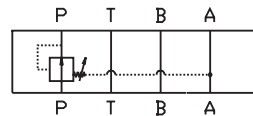

Pressure Relief Valves

Series RM, ZDV

- Parker RM, ZDV sandwich style relief valve is a 'P' port to 'T' port relief.
- Valve bodies are manufactured from steel which provide extra strength and durability for longer life. Internal hardened steel components also provide longer life.
- Three pressure adjustment options available: slotted screw, knob and locking knob.

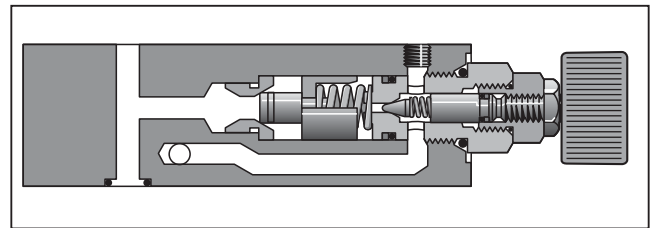

RM*PT, ZDV-P

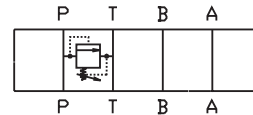

General Description

Series CM check valves provide an integral, full flow check valve in the pressure 'P' port, 'A' port, 'B' port, or the tank 'T' port of the directional valve. Reverse flow is blocked. The CM2 and CM3 sizes offer a combination P&T check version.

Features

- Valve bodies are manufactured from steel which provides extra strength and durability for longer life. Internal hardened steel components also provide longer life.
- Positive shut-off is provided by a fully guided poppet and allows full flow in the unchecked position.
- Parker CM sandwich style check valves can be used either on the 'P', 'A', 'B', 'T' ports, or combinations.
- Large internal flow paths allow high flow at low pressure drop.

Specifications

	CM2	CM3	CM6
Mounting Pattern	NFPA D03, CETOP 3, NG6	NFPA D05, CETOP 5, NG10	NFPA D08, CETOP 8, NG25
Maximum Pressure	345 Bar (5000 PSI)	345 Bar (5000 PSI)	345 Bar (5000 PSI)
Maximum Flow	76 LPM (20 GPM)	113 LPM (30 GPM)	340 LPM (90 GPM)
Cracking Pressure	0.3 Bar (5 PSI), 3 Bar* (45 PSI), 5 Bar* (75 PSI)	0.3 Bar (5 PSI), 3 Bar* (45 PSI), 5 Bar* (75 PSI)	0.3 Bar (5 PSI)

* Optional

Performance Curves

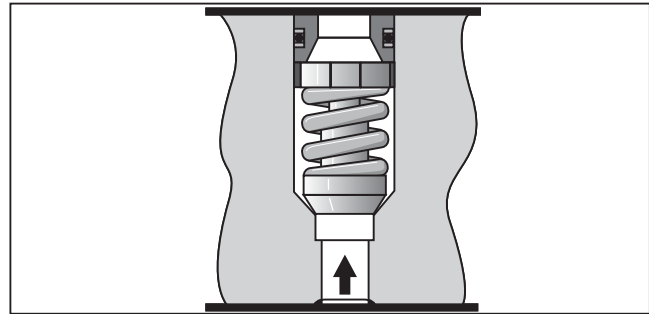
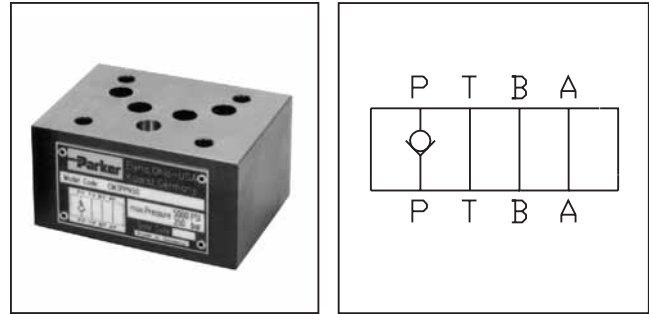
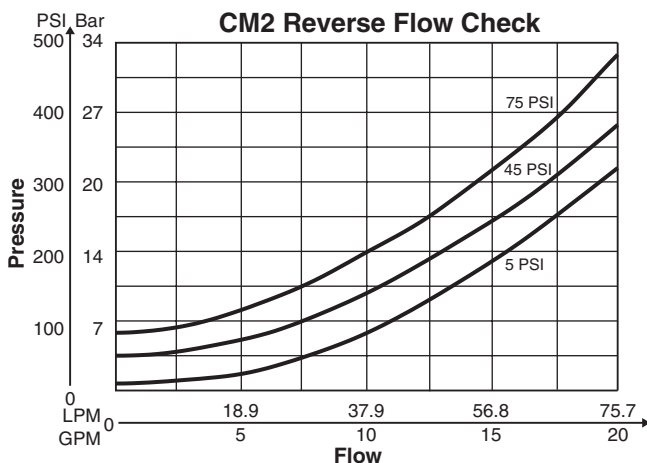

B

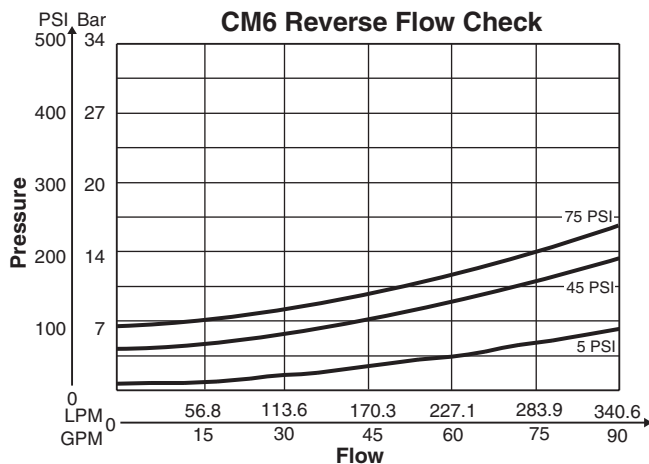
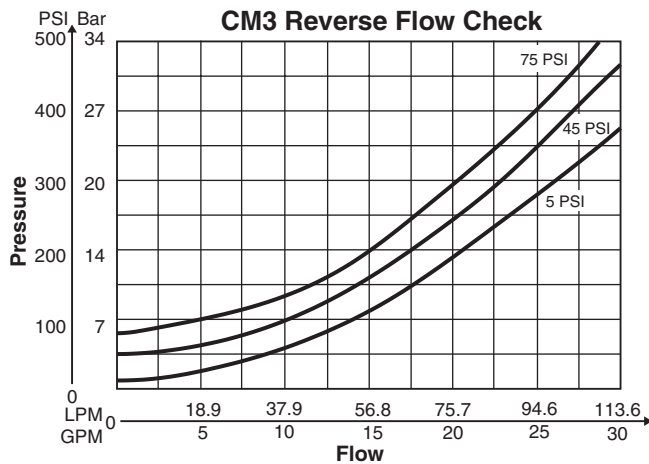

VISCOSITY CORRECTION FACTOR							
Viscosity (SSU)	75	150	200	250	300	350	400
% of ΔP (Approx.)	93	111	119	126	132	137	141

Curves were generated using 100 SSU hydraulic oil. For any other viscosity, pressure drop will change per chart.

CM

Check Valve

Size

Port

Cracking Pressure

Seal

Design Series

NOTE:
 Not required when ordering.

Code	Description
2	NFPA D03 Subplate Mounting
3	NFPA D05 Subplate Mounting
6	NFPA D08 Subplate Mounting

Code	Description
PP*	P Port Check
PT*	P and T Port Checks
TT*	T Port Check
DD	A and B Port Checks
AA	A Port Check
BB	B Port Check
AAF	A Port Inverted
BBF	B Port Inverted
DDF	A and B Ports Inverted

Code	Type
Omit	5 PSI
Y	45 PSI*
Z	75 PSI*

Code	Type
V	Fluorocarbon
N	Nitrile

* Not available on 6 size.

* Not available on 6 size

Bold: Designates Tier I products and options.

Non-Bold: Designates Tier II products and options. These products will have longer lead times.

Manapak Bolt Kits

Size "2"				Size "3"			
No. of Sandwich	Sandwich & Valve Combination	Bolt Kit	Bolt Length mm (in)	No. of Sandwich	Sandwich & Valve Combination	D3W-30 D3DW & D31*W*	Bolt Length mm (in)
1	Sandwich & D1	BK243	73.2 (2.88)	1	Sandwich & D3	BK141	88.9 (3.50)
2	Sandwich & D1	BK225	111.3 (4.38)	2	Sandwich & D3	BK142	139.7 (5.50)
3	Sandwich & D1	BK244	152.4 (6.00)	3	Sandwich & D3	BK143	190.5 (7.50)
4	Sandwich & D1	BK245	190.5 (7.50)				

Bolt Kits must be ordered separately. *D31VW with internal pilot and internal drain only.

Size "6"					
Sandwich & Valve Combination	Bolt Kit	Description	Qty/Kit	Torque IN-LBS	
1 Sandwich & D6*VW Valve	BK121	1/2 - 13 x 5.25	6	80	
2 Sandwich & D6*VW Valve	BK122	1/2 - 13 x 8.00	6	80	
3 Sandwich & D6*VW Valve	BK123	1/2 - 13 x 10.75	6	80	
4 Sandwich & D6*VW Valve	BK124	1/2 - 13 x 13.50	6	80	

Unit Weight:

CM2 0.8 kg (1.7 lbs.)
 CM3 1.8 kg (3.9 lbs.)
 CM6 7.7 kg (17 lbs.)

Note: Bolt Kits must be ordered separately.

Schematics

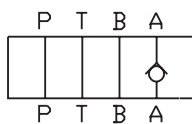

AA Option

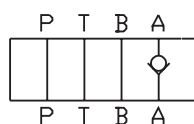

AAF Option

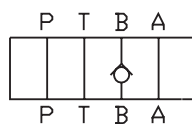

BB Option

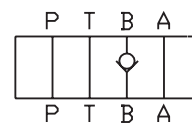

BBF Option

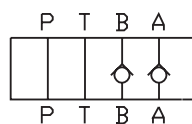

DD Option

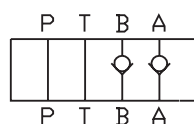

DDF Option

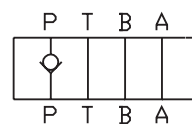

PP Option

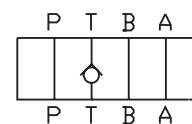

TT Option

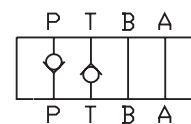

PT Option

Inch equivalents for millimeter dimensions are shown in (**)

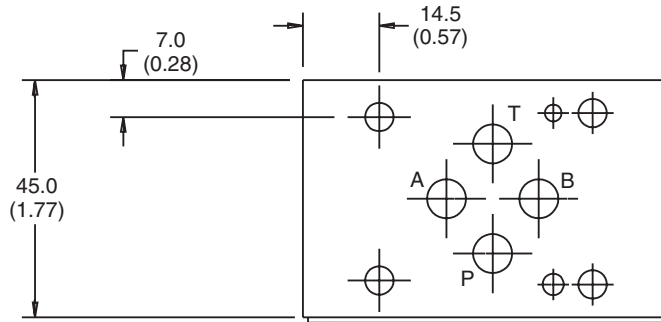

Top View

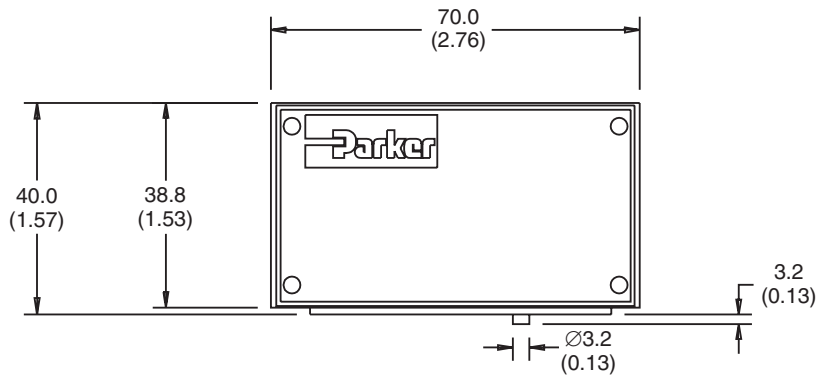

Face View

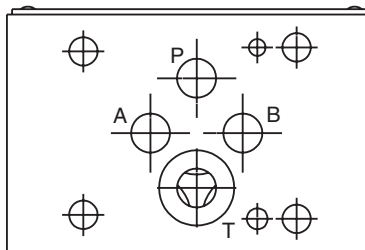

SHOWN WITHOUT O-RING PLATE

Bottom View

B



Note: Transfer the locating pin to the hole on the opposite side of the valve body for 'T' port option.
(Invert body 180°)

B

Bottom Views

Top Views

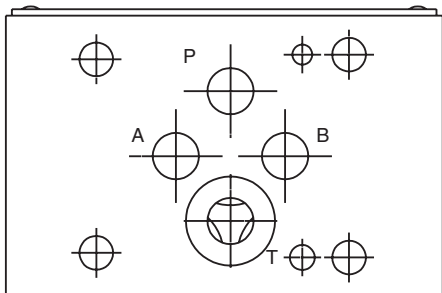

TT

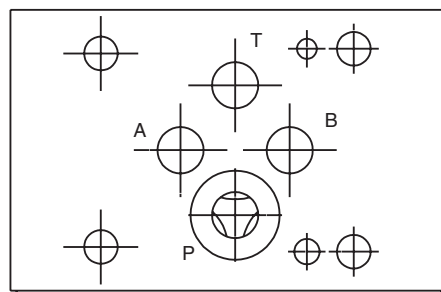

PP/PT

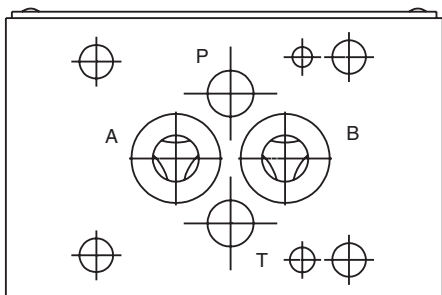

DD

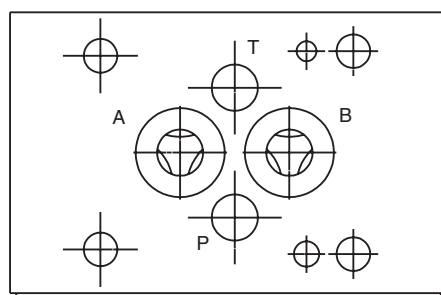

DDF

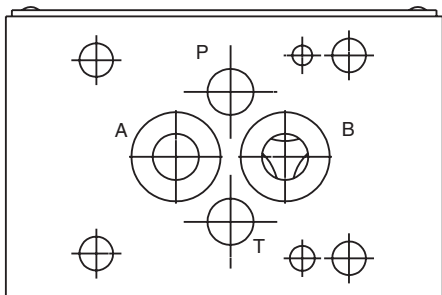

BB

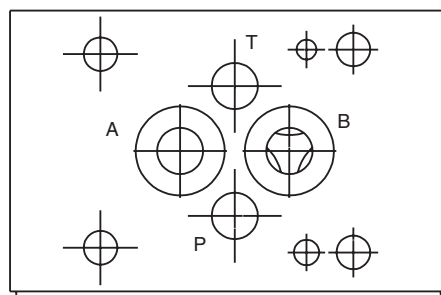

BBF

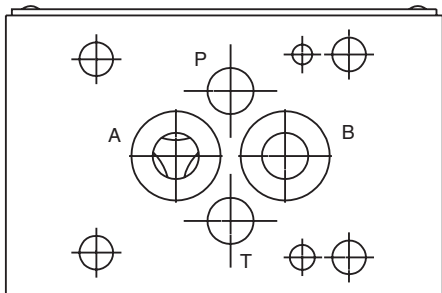

AA

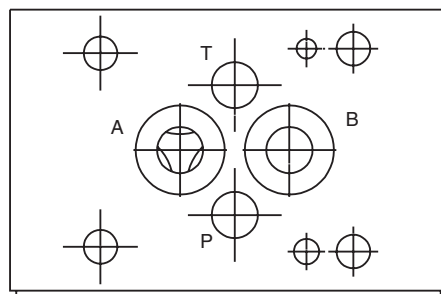

AAF

Inch equivalents for millimeter dimensions are shown in (**)

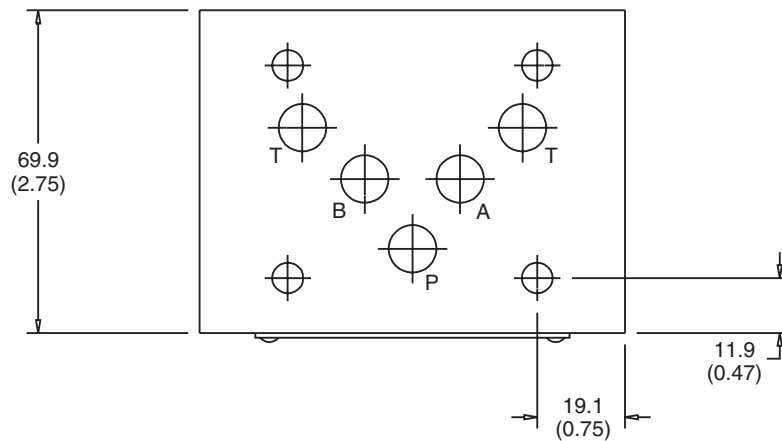

Top View

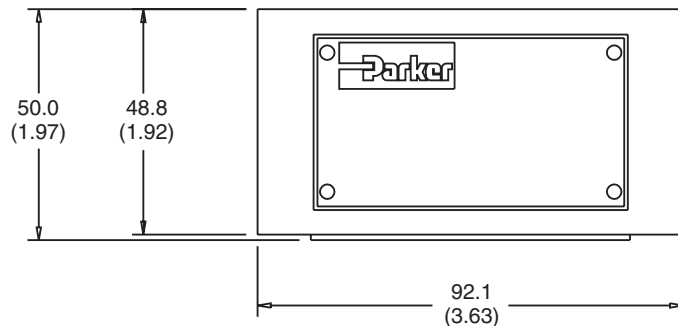

Face View

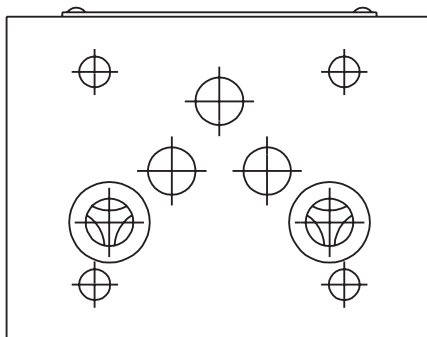

SHOWN WITHOUT O-RING PLATE

Bottom View

B



B

Bottom Views

Top Views

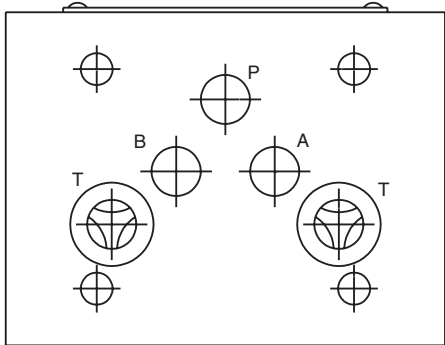

TT

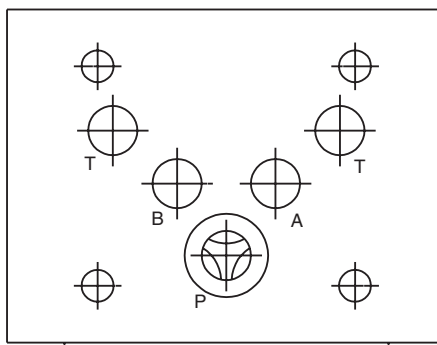

PP/PT

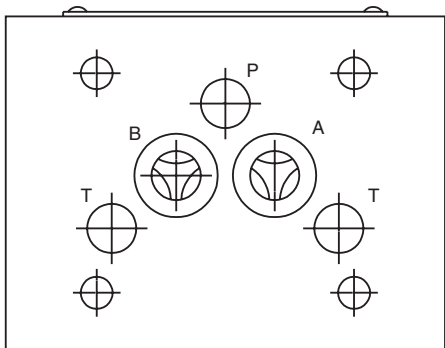

DD

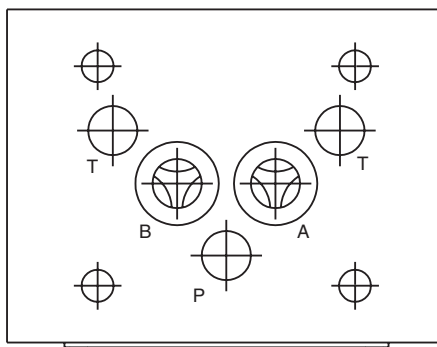

DDF

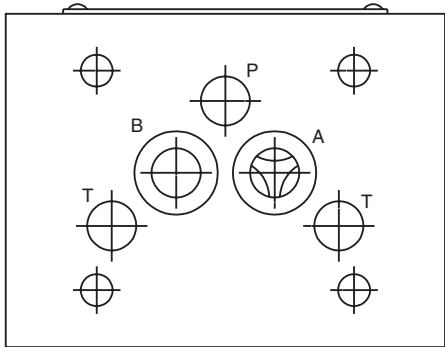

AA

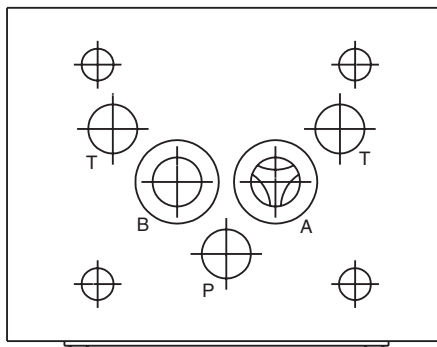

AAF

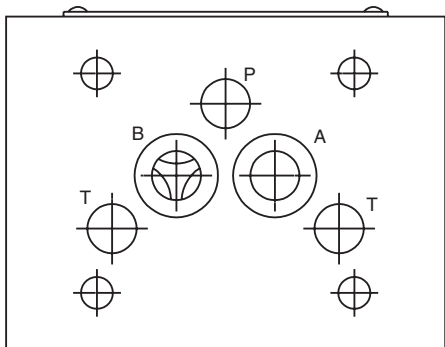

BB

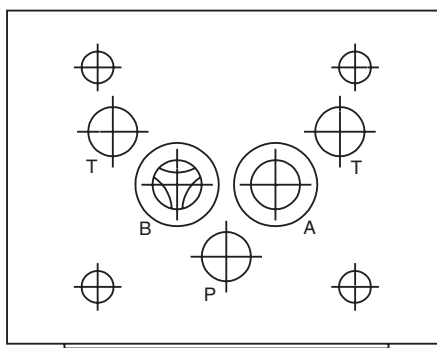

BBF

Inch equivalents for millimeter dimensions are shown in (**)

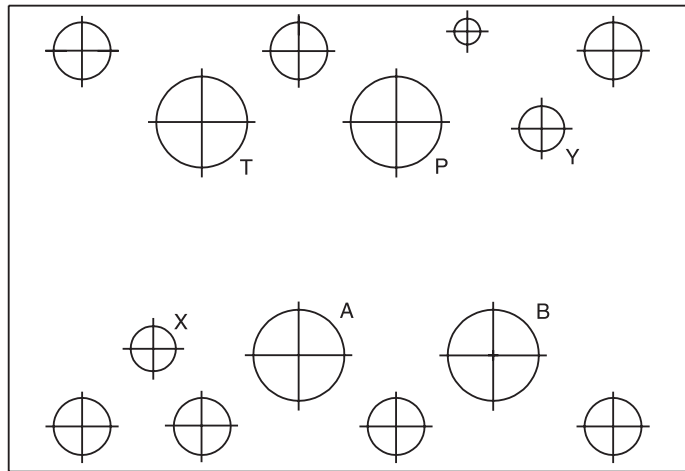

Top View

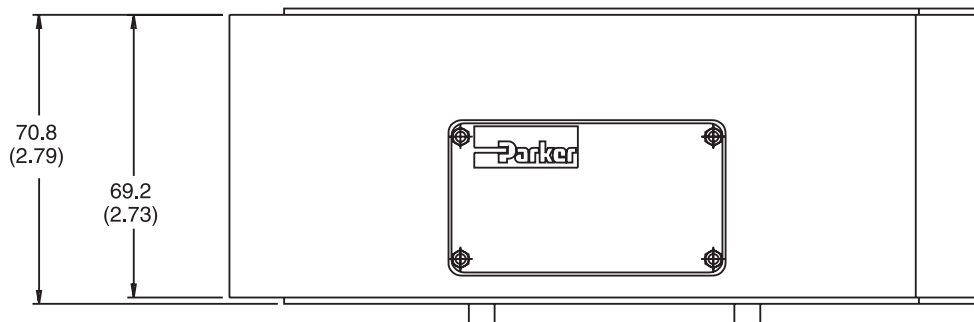

Face View

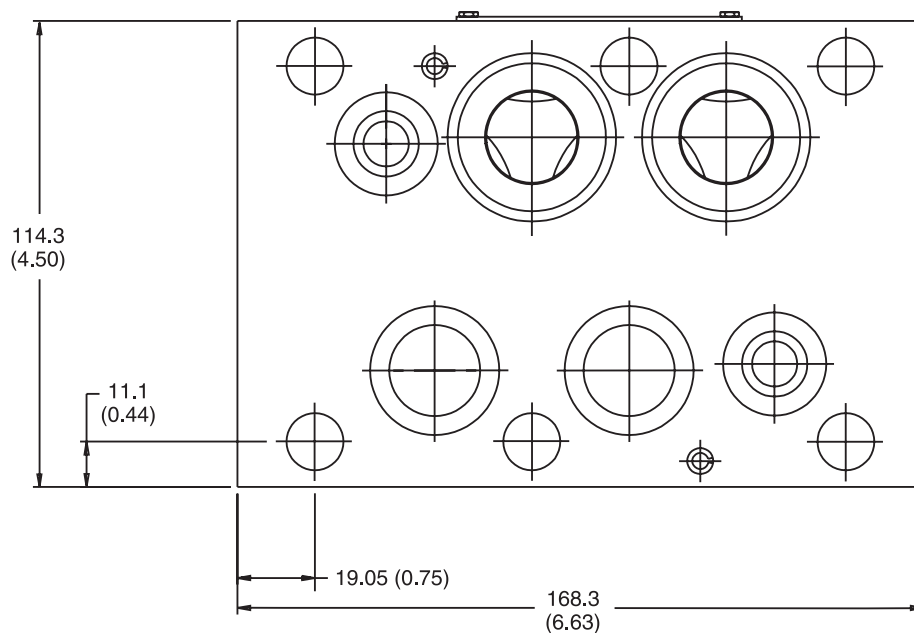

Bottom View

B



B

Bottom Views

Top Views

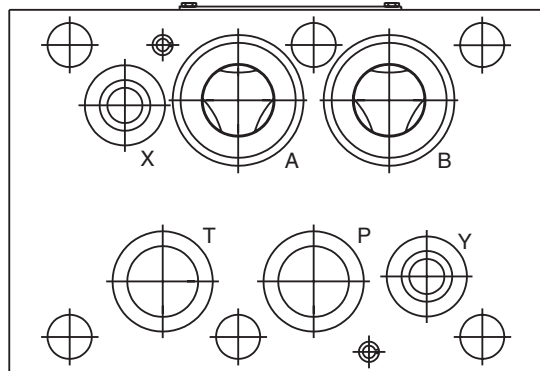

DD

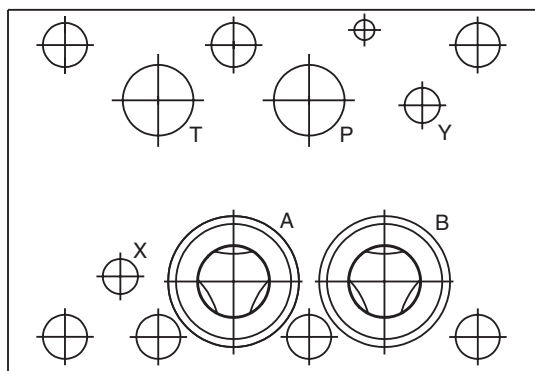

DDF

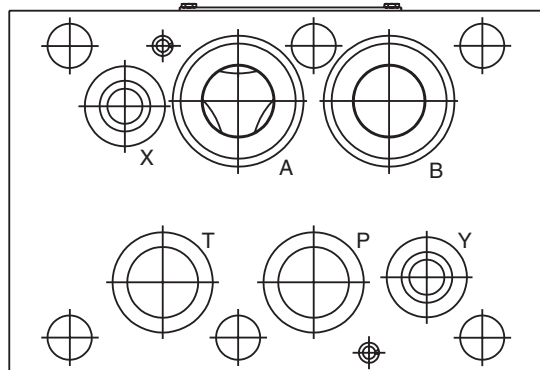

AA

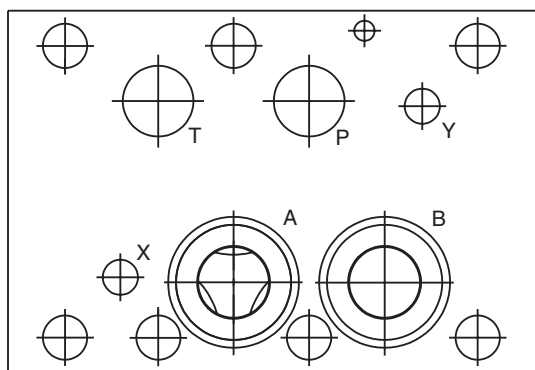

AAF

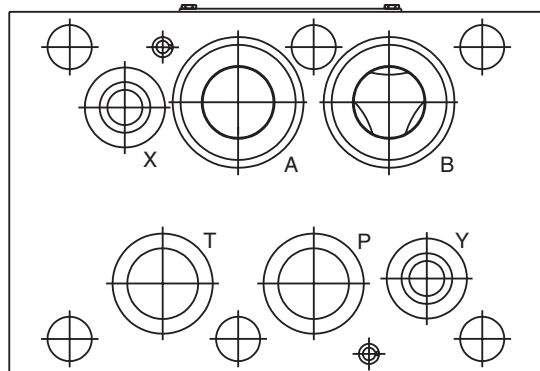

BB

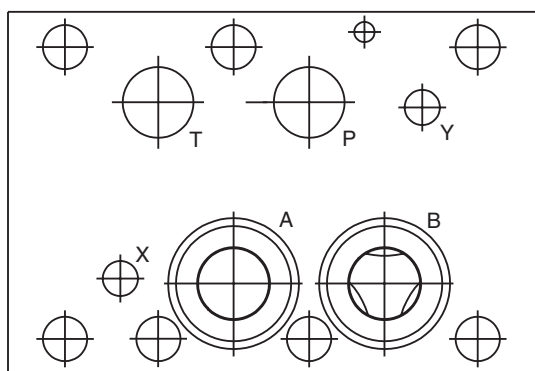

BBF

General Description

Series CPOM double pilot operated check valves block leakage from the actuator ports to tank when the directional valve is in the center position.

NOTE: For max. response and shut off, a directional valve with both cylinder ports drained to tank in the center position is recommended for use with sandwich double pilot operated check valves.

Features

- Parker CPOM sandwich style, p.o. check valves can be provided in either single or double configurations.
- The p.o. checks may be positioned in 'A' port or 'B' port; or both 'A' and 'B' ports.
- Valve bodies are manufactured from steel providing extra strength and durability for longer life. Internal hardened steel components also provide longer life.
- Positive shut-off is provided by a hardened poppet and cage assembly.
- Large internal flow paths allow high flow at low pressure drop.

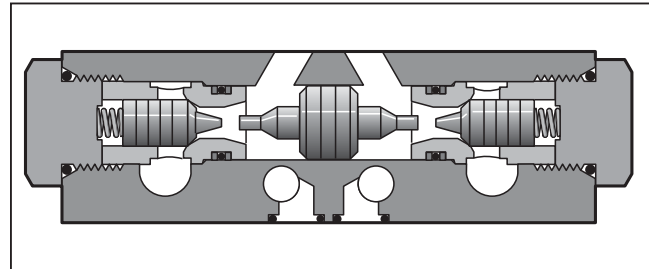
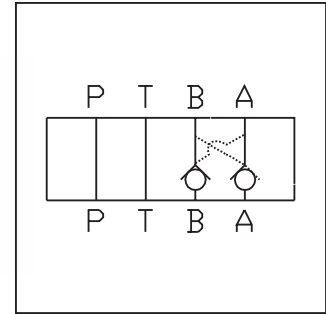

B

Performance Curves

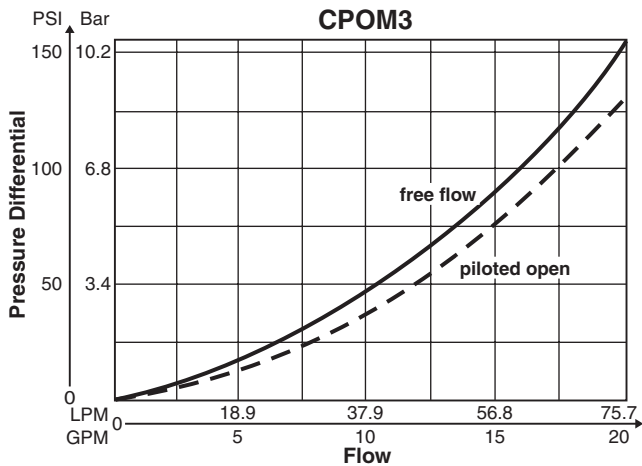
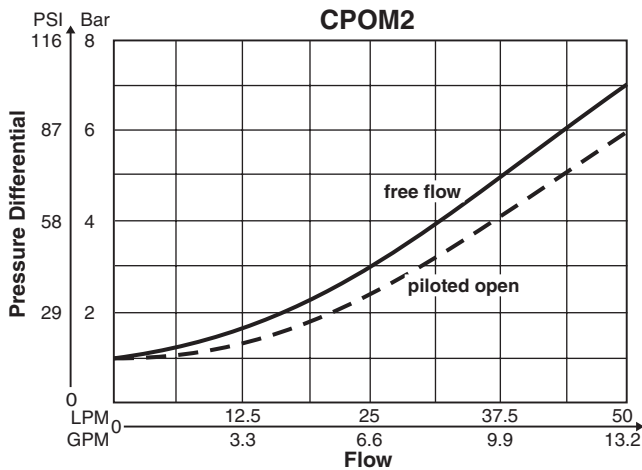

Specifications

	CPOM2	CPOM3	CPOM6
Mounting Pattern	NFPA D03, CETOP 3, NG 6	NFPA D05, CETOP 5, NG 10	NFPA D08, CETOP 8, NG 25
Maximum Pressure	345 Bar (5000 PSI)	345 Bar (5000 PSI)	205 Bar (3000 PSI)
Maximum Flow	53 LPM (14 GPM) @ 21 Bar (305 PSI) Pressure Drop	76 LPM (20 GPM) @ 11 Bar (155 PSI) Pressure Drop	227 LPM (60 GPM) @ 24 Bar (350 PSI) Pressure Drop
Cracking Pressure	1.0 Bar (15 PSI)	0.3 Bar (5 PSI)	0.4 Bar (6 PSI)
Pilot Ratio	3:1	3:1	3:1
Leakage	5 DPM	5 DPM	5 DPM

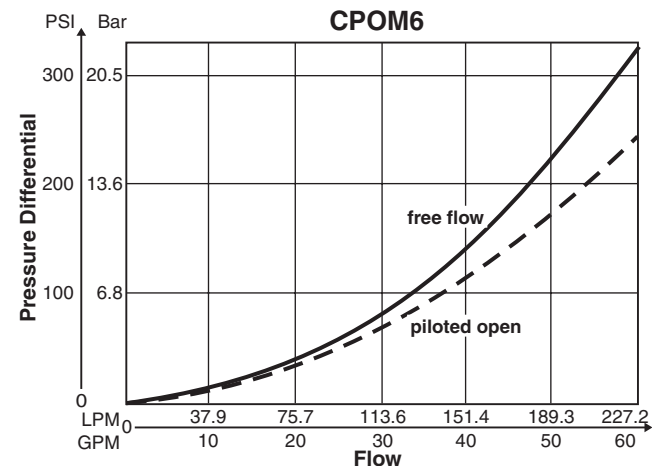

Curves were generated using 100 SSU hydraulic oil. For any other viscosity, pressure drop will change as per chart.	Viscosity Correction Factor							
	Viscosity (SSU)	75	150	200	250	300	350	400
	Percentage of ΔP (Approx.)	93	111	119	126	132	137	141

Parker Sandwich.indd, dd



CPOM

Pilot Operated Check Valve

Size

Poppet Style

Poppet Style

Cracking Pressure

Cracking Pressure

Seal

Seal

*

Design Series
 NOTE:
 Not required when ordering.

B

Code	Description
2	NFPA D03 Subplate Mounting
3	NFPA D05 Subplate Mounting
6	NFPA D08 Subplate Mounting

Code	Description
DD	Double Poppet A and B Ports
AA	A Port Only
BB	B Port Only

Code	Type
Omit**	5 PSI
Y*	45 PSI
Z*	75 PSI

* Available in size 2 only.
 ** 15 PSI on CPOM2

Code	Type
N	Nitrile
V	Fluorocarbon

Bold: Designates Tier I products and options.

Non-Bold: Designates Tier II products and options. These products will have longer lead times.

Bolt Kits

Size "2"				Size "3"			
No. of Sandwich	Sandwich & Valve Combination	Bolt Kit	Bolt Length mm (in)	No. of Sandwich	Sandwich & Valve Combination	D3W-30 D3DW & D31*W*	Bolt Length mm (in)
1	Sandwich & D1	BK243	73.2 (2.88)	1	Sandwich & D3	BK141	88.9 (3.50)
2	Sandwich & D1	BK225	111.3 (4.38)	2	Sandwich & D3	BK142	139.7 (5.50)
3	Sandwich & D1	BK244	152.4 (6.00)	3	Sandwich & D3	BK143	190.5 (7.50)
4	Sandwich & D1	BK245	190.5 (7.50)				

* D31VW with internal pilot and internal drain only.

Size "6"			
No. of Sandwich	Sandwich & Valve Combination	Bolt Kit	Bolt Length mm (in)
1	Sandwich & D6	BK121	133.4 (5.25)
2	Sandwich & D6	BK122	203.2 (8.00)
3	Sandwich & D6	BK123	273.1 (10.75)
4	Sandwich & D6	BK124	342.9 (13.5)

Unit Weight:

CPOM2D 0.8 kg (1.7 lbs.)
 CPOM3D 4.4 kg (9.6 lbs.)
 CPOM6D 9.5 kg (21.0 lbs.)

Bolt Kits must be ordered separately.

Schematics

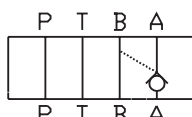

AA Option

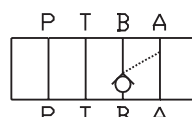

BB Option

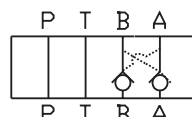

DD Option

Inch equivalents for millimeter dimensions are shown in (**)

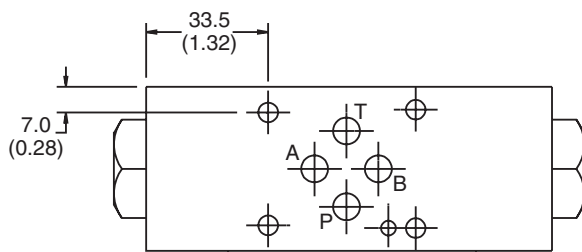

Top View

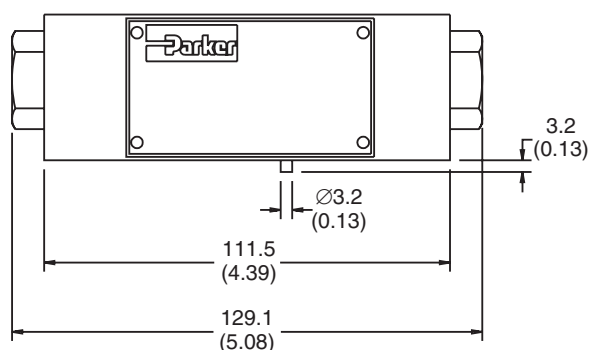

Face View

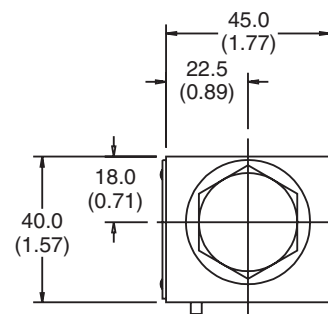

End View

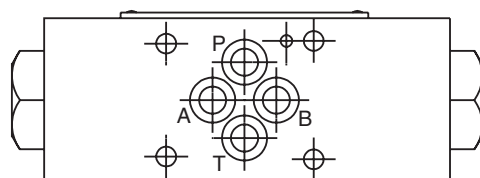

Bottom View

B



Inch equivalents for millimeter dimensions are shown in (**)

B

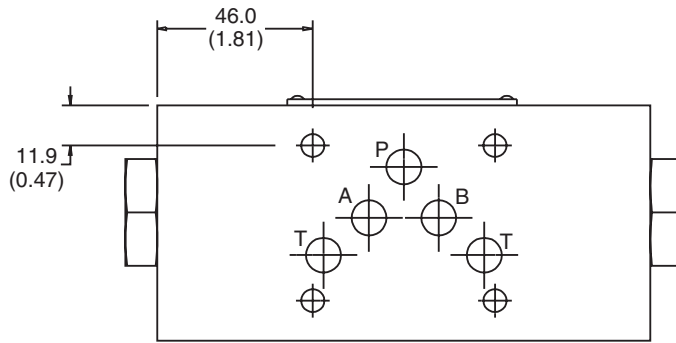

Top View

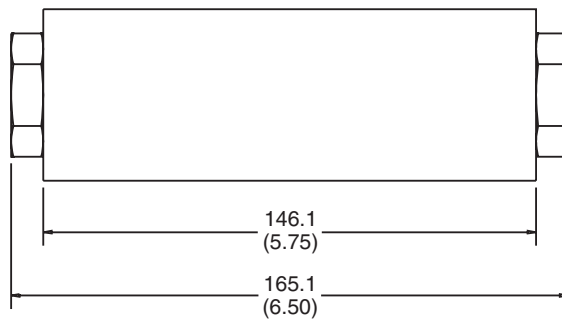

Face View

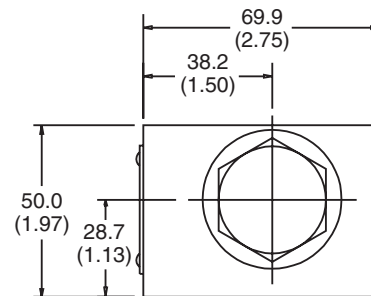

End View

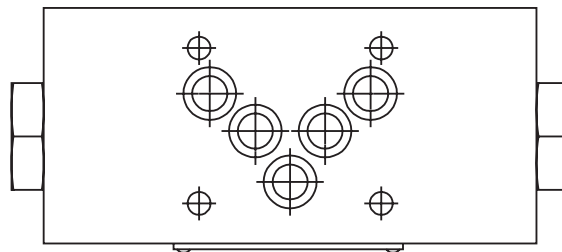

Bottom View



Inch equivalents for millimeter dimensions are shown in (**)

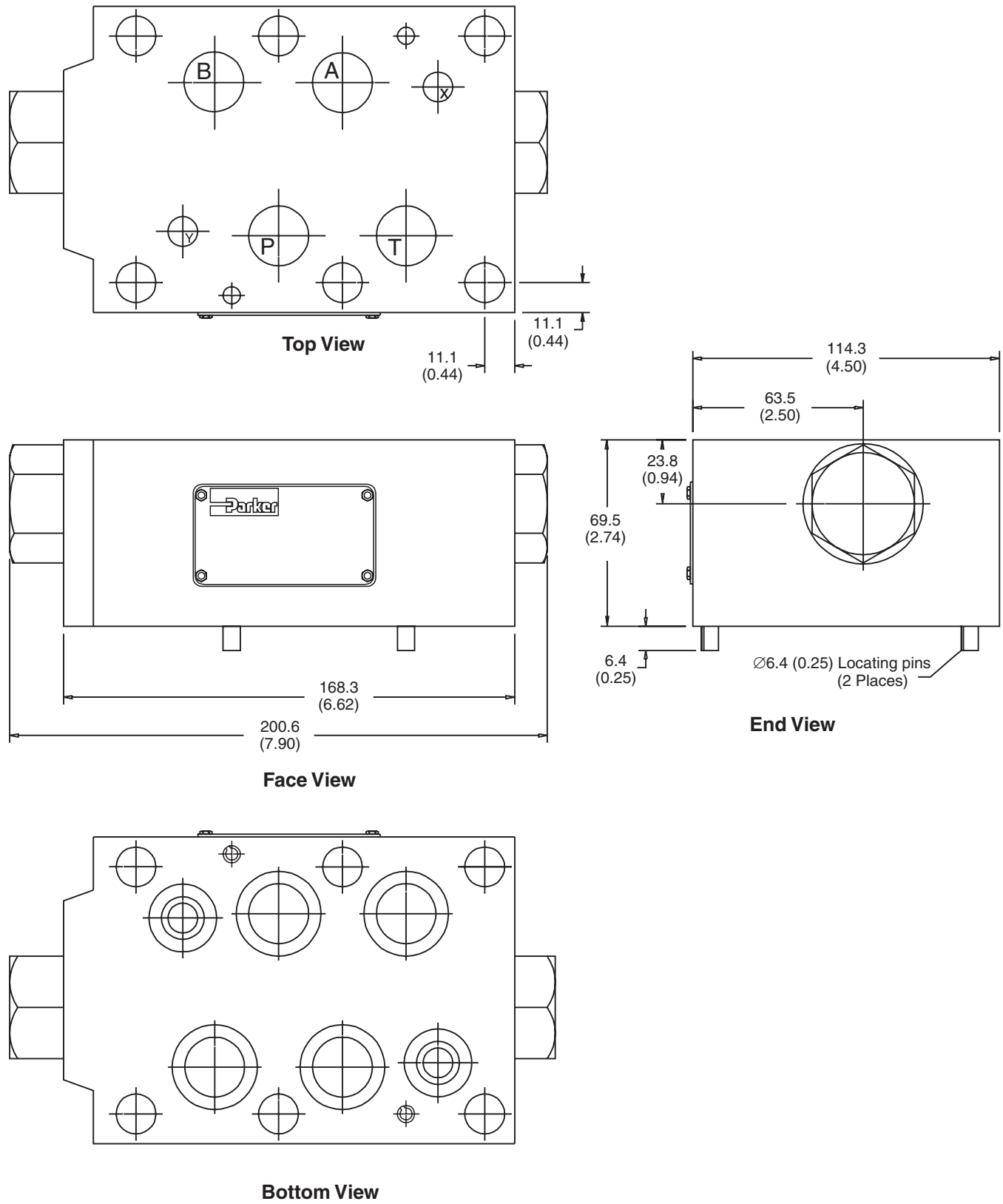

B



General Description

Series FM double flow control valves permit free flow from the directional valve to the actuator and adjustable independent flow regulation in each return line from the actuator (meter-out). The FM2 and FM3 have a seal plate and can be inverted for meter-in applications (see installation drawing for flow direction).

Features

- FM style flow control valves can be provided in either single or double configurations.
- The flow controls may be positioned in 'A' port, 'B' port, both 'A' and 'B' ports or 'P' port.
- Valve bodies are manufactured from steel providing extra strength and durability for longer life. Internal hardened steel components also provide longer life.
- Two step needles provide fine adjustment for the first few turns and course adjustment for the last few turns. Standard and fine adjustment needles available.
- Large bypass checks allow high flow at a low pressure drop.
- Valve is reversible (invert 180°) for meter-in or meter-out applications (FM2 and FM3 only).
- Adjustment options include Allen hex or hand knob.

Performance Curves

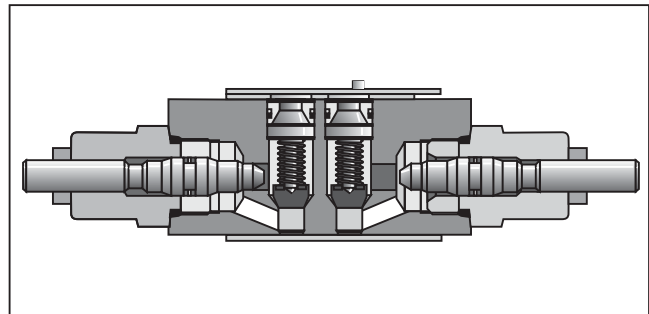
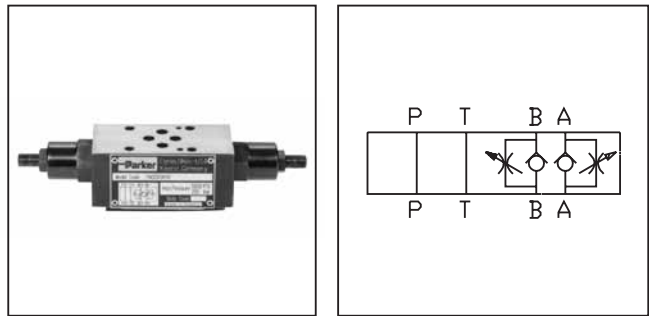
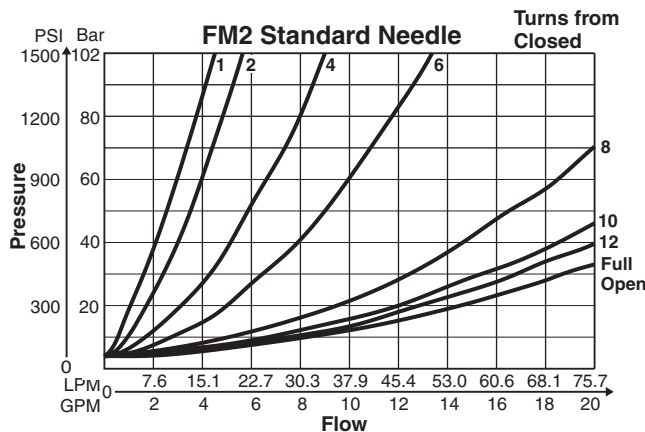
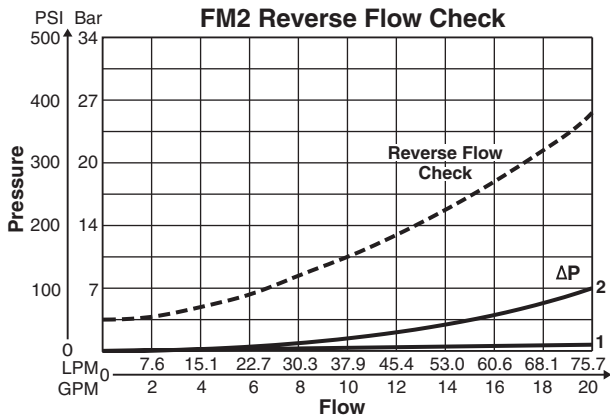

Specifications

	FM2	FM3	FM6
Mounting Pattern	NFPA D03, CETOP 3, NG 6	NFPA D05, CETOP 5, NG 10	NFPA D08, CETOP 8, NG 25
Maximum Pressure	345 Bar (5000 PSI)	345 Bar (5000 PSI)	205 Bar (3000 PSI)
Maximum Flow	76 LPM (20 GPM)	113 LPM (30 GPM)	341 LPM (90 GPM)
Cracking Pressure	0.3 Bar (5 PSI)	0.3 Bar (5 PSI)	0.3 Bar (5 PSI)

Pressure Drop Reference Chart

	P	A	B	T
PP	*	2	2	1
DD	1	*	*	1
AA	1	*	1	1
BB	1	1	*	1

* See specific flow vs. turns

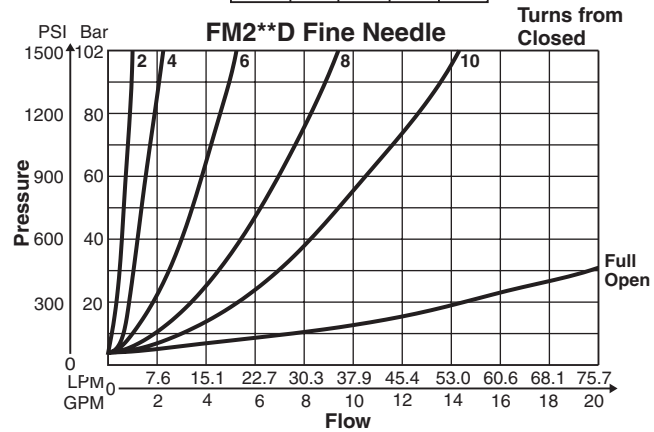

Curves were generated using 100 SSU hydraulic oil @49°C (120°F). For any other viscosity, pressure drop will change as per chart.

Viscosity Correction Factor							
Viscosity (SSU)	75	150	200	250	300	350	400
Percentage of ΔP (Approx.)	93	111	119	126	132	137	141

Parker Sandwich.indd, dd

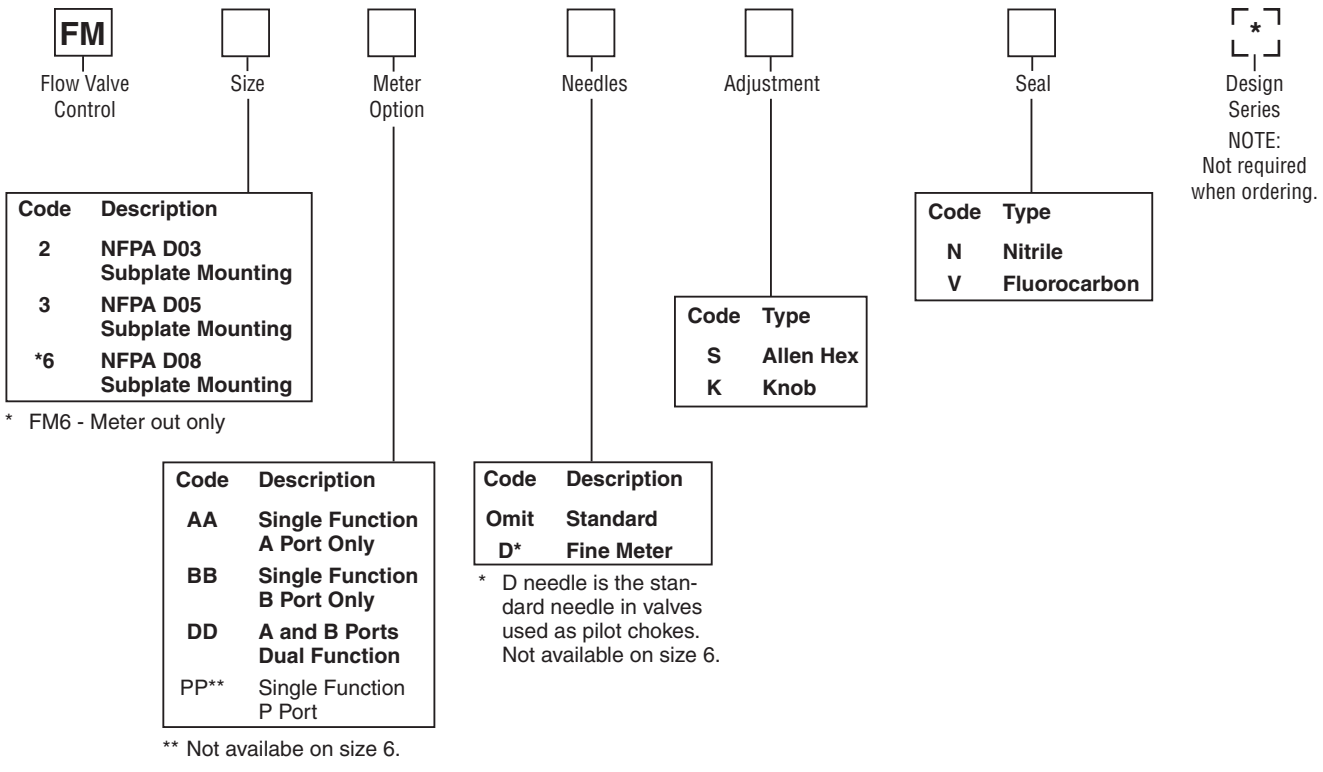

Bold: Designates Tier I products and options.
Non-Bold: Designates Tier II products and options. These products will have longer lead times.

Bolt Kits

Size "2"				Size "3"			
No. of Sandwich	Sandwich & Valve Combination	Bolt Kit	Bolt Length mm (in)	No. of Sandwich	Sandwich & Valve Combination	D3W-30 D3DW & D31*W*	Bolt Length mm (in)
1	Sandwich & D1	BK243	73.2 (2.88)	1	Sandwich & D3	BK141	88.9 (3.50)
2	Sandwich & D1	BK225	111.3 (4.38)	2	Sandwich & D3	BK142	139.7 (5.50)
3	Sandwich & D1	BK244	152.4 (6.00)	3	Sandwich & D3	BK143	190.5 (7.50)
4	Sandwich & D1	BK245	190.5 (7.50)				

* D31VW with internal pilot and internal drain only.

Size "6"			
No. of Sandwich	Sadnwich & Valve Combination	Bolt Kit	Bolt Length mm (in)
1	Sandwich & D6	BK121	133.4 (5.25)
2	Sandwich & D6	BK122	203.2 (8.00)
3	Sandwich & D6	BK123	273.1 (10.75)
4	Sandwich & D6	BK124	342.9 (13.5)

Unit Weight:

- FM2 1.7 kg (3.8 lbs.)
- FM3 2.4 kg (5.2 lbs.)
- FM6 7.9 kg (17.5 lbs.)

Bolt Kits must be ordered separately.

Schematics

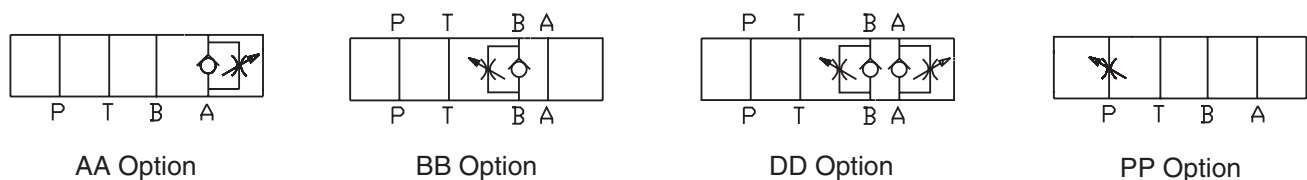

B

Pressure Drop Reference Chart

	P	A	B	T
PP	*	2	2	1
DD	1	*	*	1
AA	1	*	1	1
BB	1	1	*	1

* See specific flow vs. turns chart

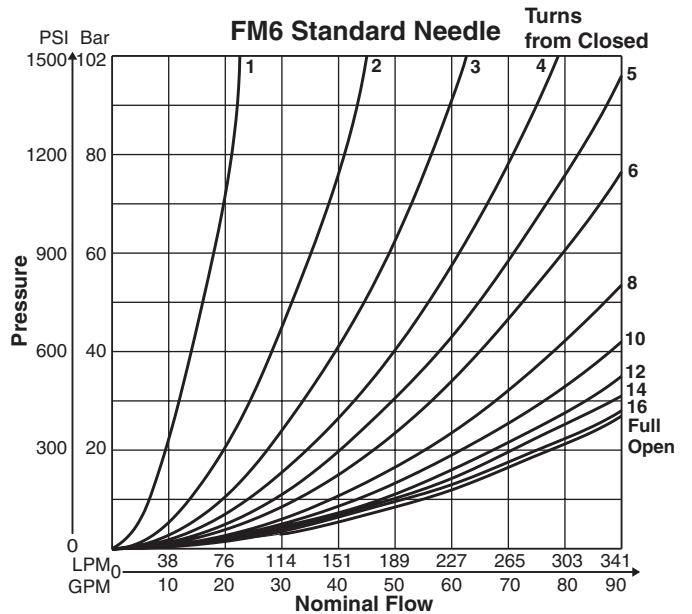
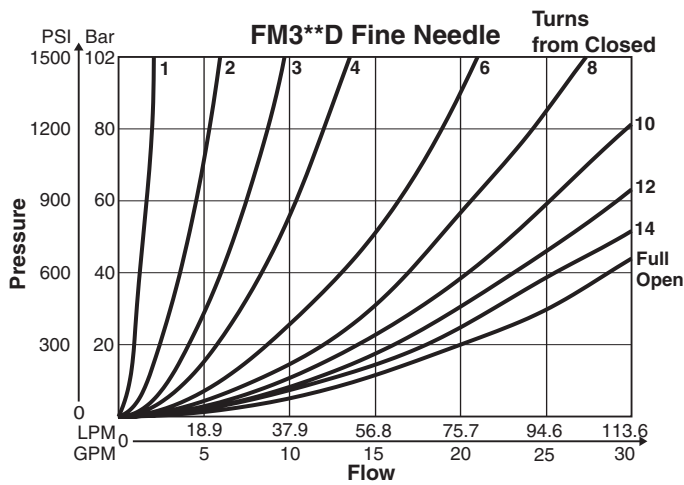
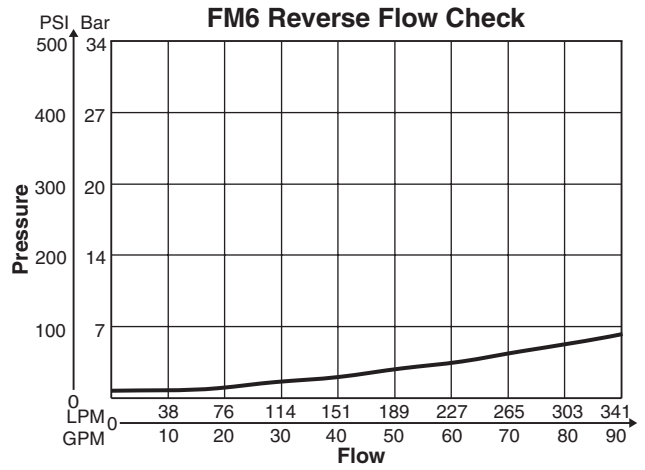
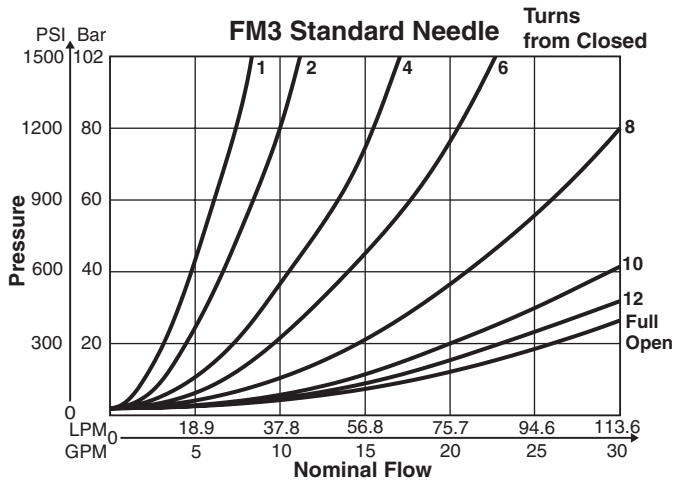
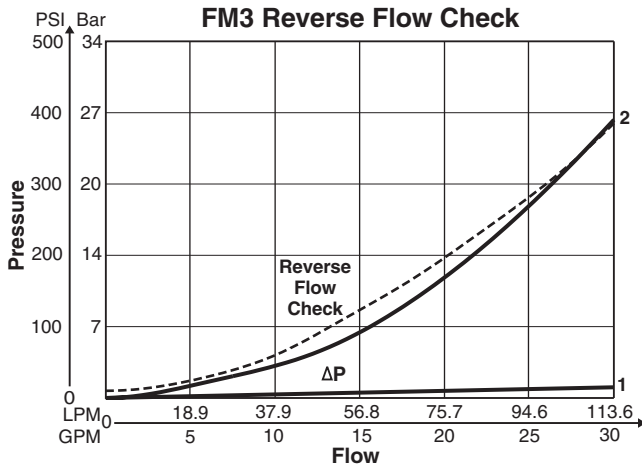

Inch equivalents for millimeter dimensions are shown in (**)

B

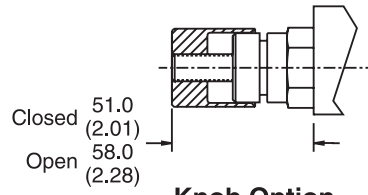

Knob Option

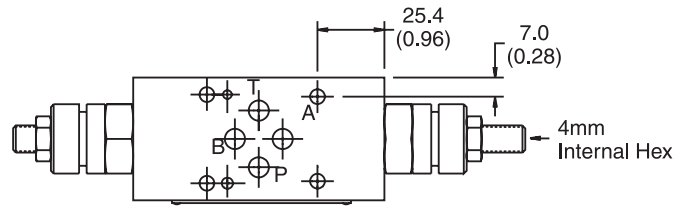

Top View

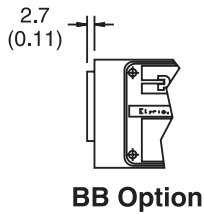

BB Option

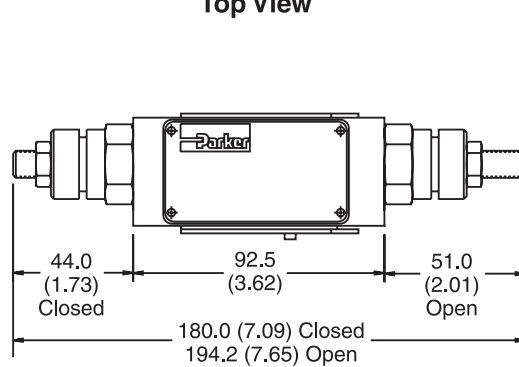

Face View

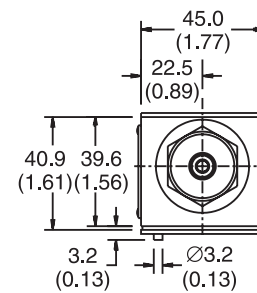

End View

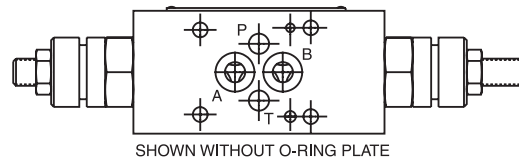

Bottom View

Note: For meter-in option, invert body 180°.



Inch equivalents for millimeter dimensions are shown in (**)

B

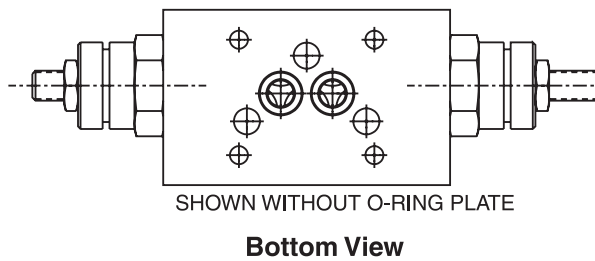
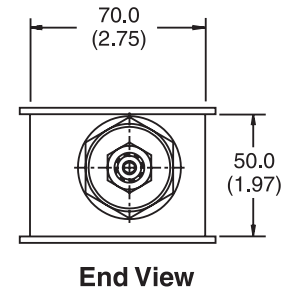
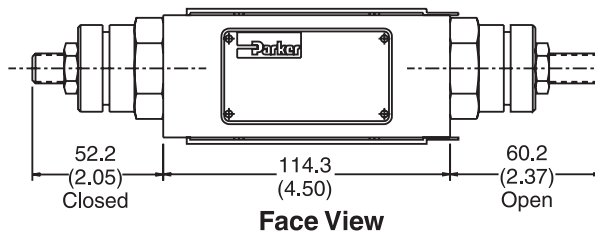
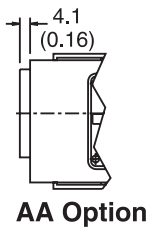
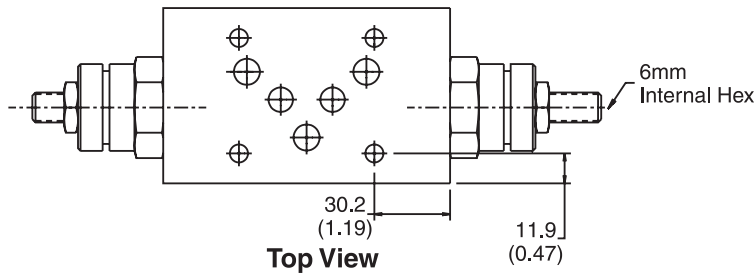
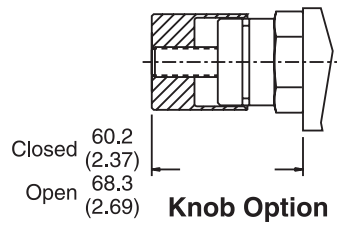

Note: For meter-in option, invert body 180°.

Inch equivalents for millimeter dimensions are shown in (**)

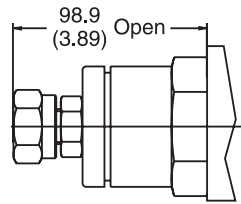

Knob Option

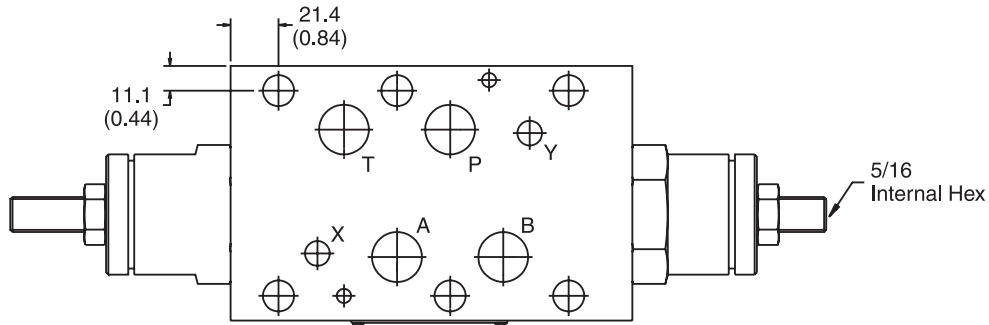

Top View

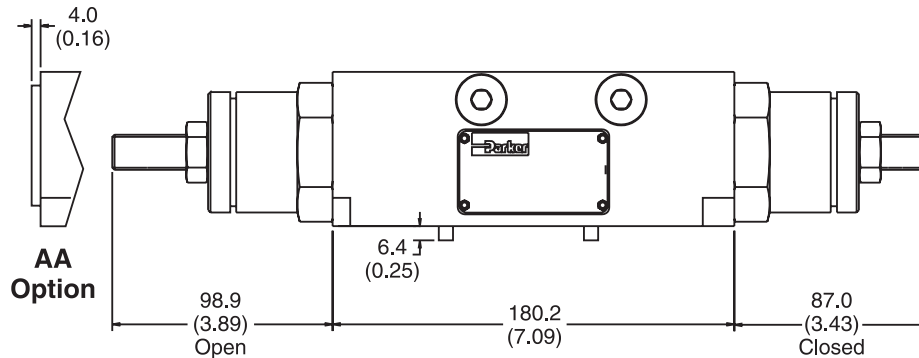

Face View

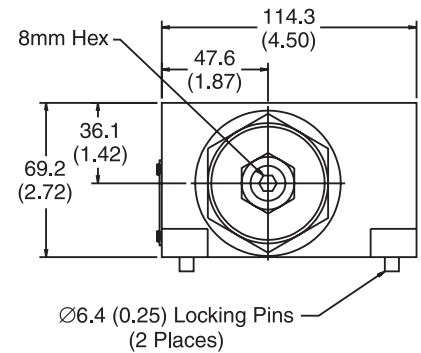

End View

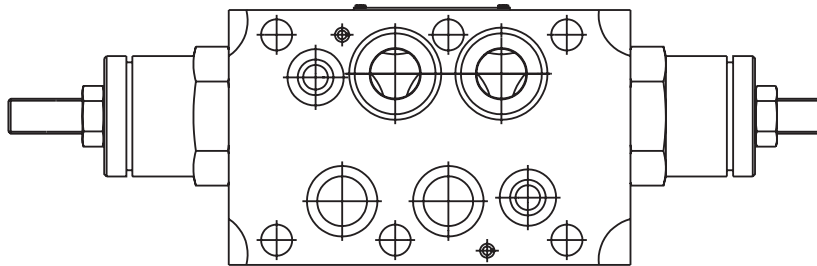

Bottom View



B

General Description

Series PRDM are direct operated pressure reducing valves that are used to regulate pressure in one area of a hydraulic circuit at a predetermined level below normal system pressure. Additionally, an integral pressure relieving function for the secondary reduced pressure circuit is incorporated into the design.

B

Operation

These valves are “normally open” devices that allow fluid to flow through the controlled port during their non-actuated or “at rest” condition. When downstream pressure exceeds the value set by the spring force, the control piston moves off its seat, closing off the flow path and thus reducing the fluid passing through from the main system. The cushioned piston modulates to maintain the preset pressure in this branch of the hydraulic circuit. If, due to external forces, the pressure continues to rise in this branch circuit, the piston will keep moving against the spring force allowing fluid to be drained to tank, thereby limiting maximum pressure to the valve’s setting.

Features

- PRDM sandwich valves may be selected to reduce pressure in the 'P' port, 'A' port or 'B' port.
- The direct operated, cushioned piston design results in fast response, low leakage and minimal hysteresis.
- Up to nine pressure adjustment ranges are available with maximum pressure settings.
- Adjustment options include: internal hex screw, hand knob or internal hex with keylock.
- Fluorocarbon seals are available.
- Available gage port connections include SAE, NPT, Metric and BSPP.

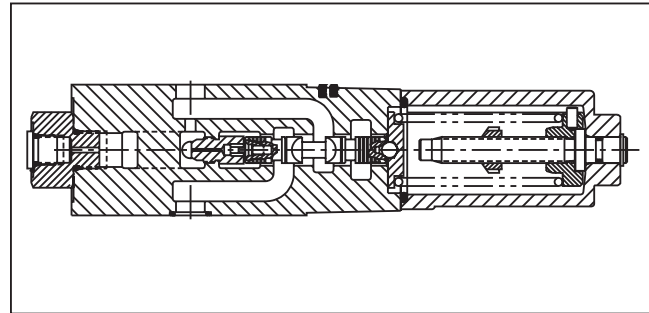
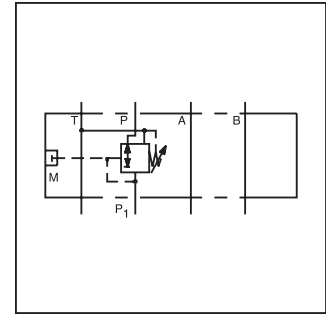
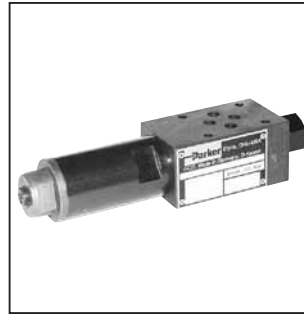

Specifications

	PRDM2	PRDM3																				
Mounting Pattern	NFPA D03, CETOP 3, NG6	NFPA D05, CETOP 5, NG10																				
Maximum Operating Pressure P, A, B	350 Bar (5000 PSI)	315 Bar (4560 PSI)																				
T	10 Bar (145 PSI)	10 Bar (145 PSI)																				
Max. Flow	40 LPM (10.5 GPM)	80 LPM (21 GPM)																				
Maximum Leakage P-A	15 ml/min (1.0 cu. in.)																					
Pressure Range	<table border="0"> <tr> <td>Code</td> <td>Range</td> </tr> <tr> <td>01</td> <td>1.0 to 14 Bar (15 to 200 PSI)</td> </tr> <tr> <td>02*</td> <td>1.5 to 25 Bar (22 to 363 PSI)</td> </tr> <tr> <td>05**</td> <td>2 to 50 Bar (29 to 725 PSI)</td> </tr> <tr> <td>06*</td> <td>1.5 to 64 Bar (22 to 928 PSI)</td> </tr> <tr> <td>10**</td> <td>4 to 100 Bar (58 to 1450 PSI)</td> </tr> <tr> <td>15**</td> <td>6 to 150 Bar (87 to 2175 PSI)</td> </tr> <tr> <td>16*</td> <td>3 to 160 Bar (44 to 2320 PSI)</td> </tr> <tr> <td>21</td> <td>8 to 210 Bar (116 to 3045 PSI)</td> </tr> <tr> <td>35*</td> <td>10 to 315 Bar (147 to 4560 PSI)</td> </tr> </table>		Code	Range	01	1.0 to 14 Bar (15 to 200 PSI)	02*	1.5 to 25 Bar (22 to 363 PSI)	05**	2 to 50 Bar (29 to 725 PSI)	06*	1.5 to 64 Bar (22 to 928 PSI)	10**	4 to 100 Bar (58 to 1450 PSI)	15**	6 to 150 Bar (87 to 2175 PSI)	16*	3 to 160 Bar (44 to 2320 PSI)	21	8 to 210 Bar (116 to 3045 PSI)	35*	10 to 315 Bar (147 to 4560 PSI)
Code	Range																					
01	1.0 to 14 Bar (15 to 200 PSI)																					
02*	1.5 to 25 Bar (22 to 363 PSI)																					
05**	2 to 50 Bar (29 to 725 PSI)																					
06*	1.5 to 64 Bar (22 to 928 PSI)																					
10**	4 to 100 Bar (58 to 1450 PSI)																					
15**	6 to 150 Bar (87 to 2175 PSI)																					
16*	3 to 160 Bar (44 to 2320 PSI)																					
21	8 to 210 Bar (116 to 3045 PSI)																					
35*	10 to 315 Bar (147 to 4560 PSI)																					
Viscosity Range	12 to 230 cSt / mm ² /s (56 to 1066 SSU)																					
Filtration	ISO Code 18/16/13 or Better																					

* PRDM2 only

** PRDM3 only.

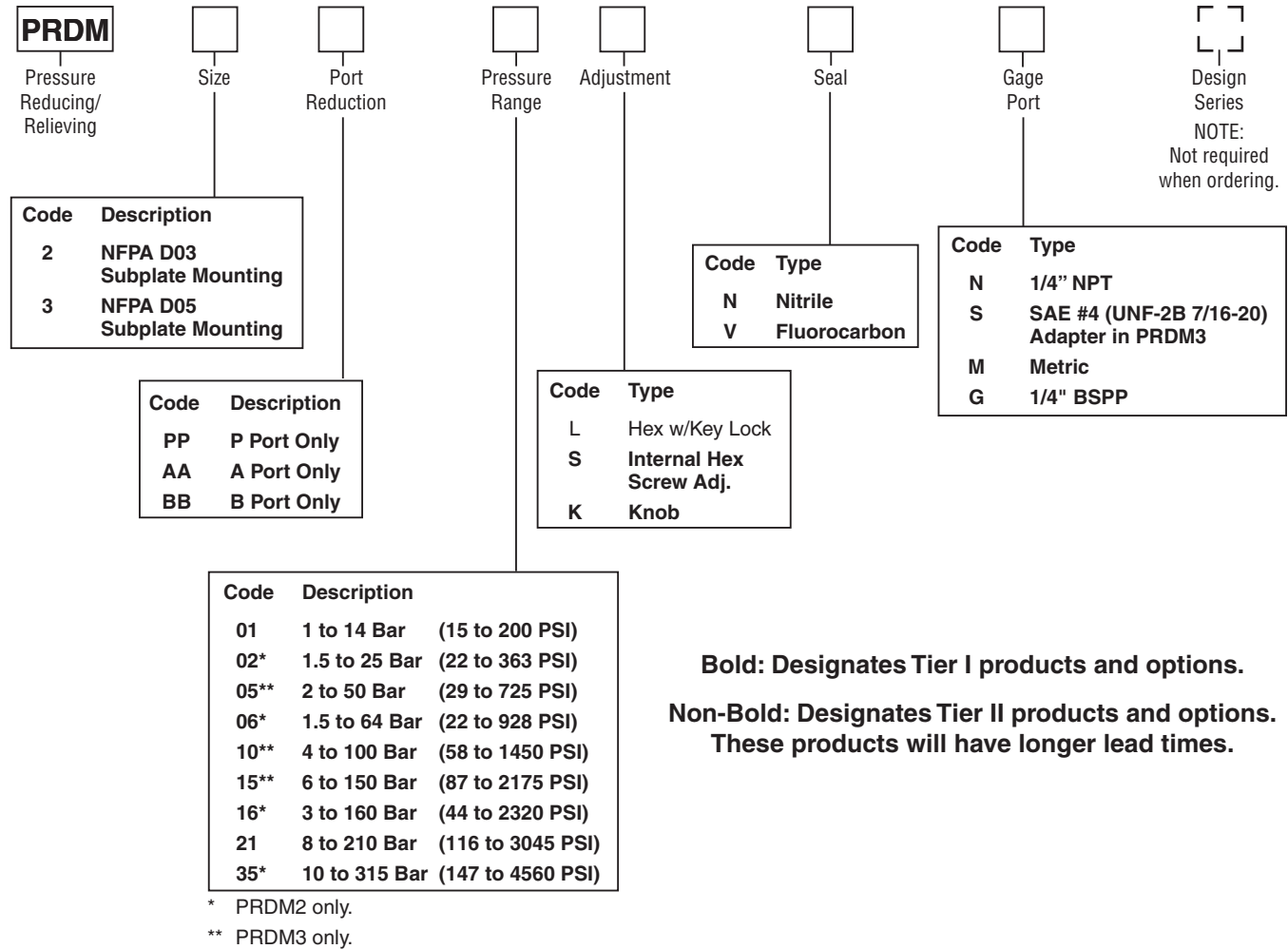

Bolt Kits

Size "2"				Size "3"			
No. of Sandwich	Sandwich & Valve Combination	Bolt Kit	Bolt Length mm (in)	No. of Sandwich	Sandwich & Valve Combination	D3W-30 D3DW & D31*W*	Bolt Length mm (in)
1	Sandwich & D1	BK243	73.2 (2.88)	1	Sandwich & D3	BK141	88.9 (3.50)
2	Sandwich & D1	BK225	111.3 (4.38)	2	Sandwich & D3	BK142	139.7 (5.50)
3	Sandwich & D1	BK244	152.4 (6.00)	3	Sandwich & D3	BK143	190.5 (7.50)
4	Sandwich & D1	BK245	190.5 (7.50)				

* D31VW with internal pilot and internal drain only.

Bolt Kits must be ordered separately.

Weights:

PRDM2 1.3 kg (2.9 lbs.)

PRDM3 2.6 kg (5.8 lbs.)

Schematics

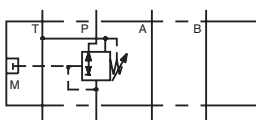

PP Option

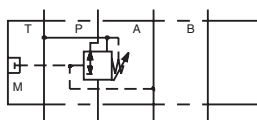

AA Option

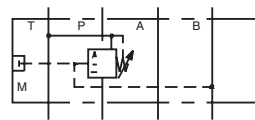

BB Option

Parker Sandwich.indd, dd

B

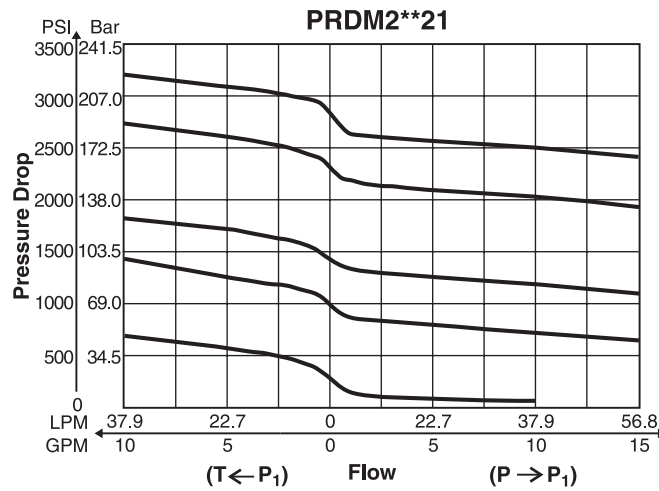
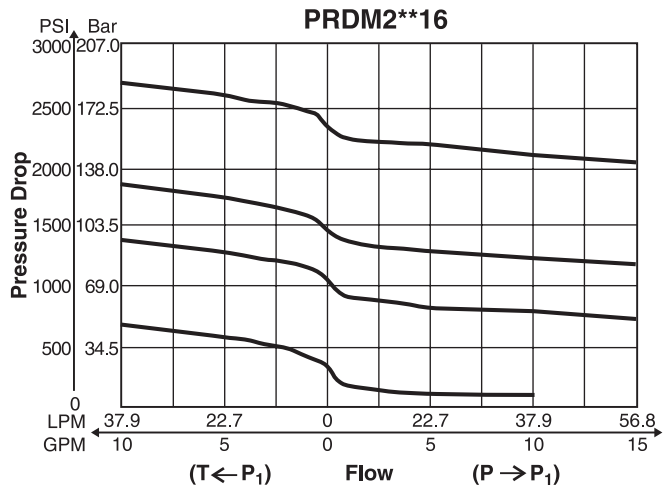
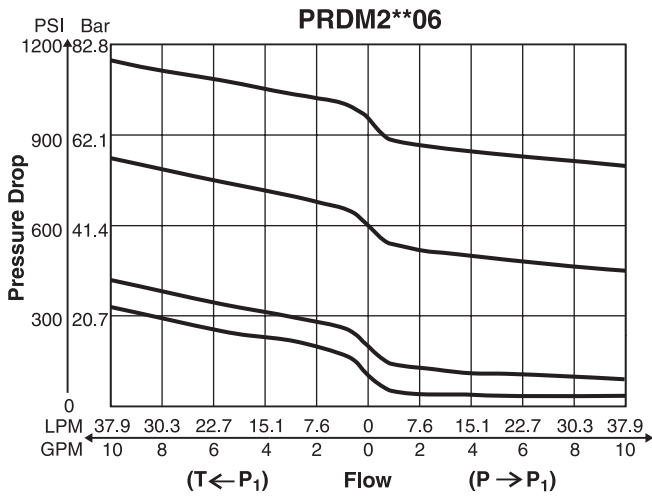
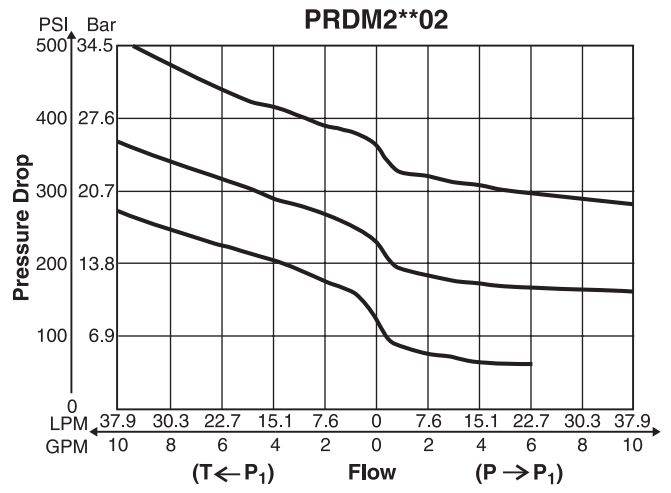
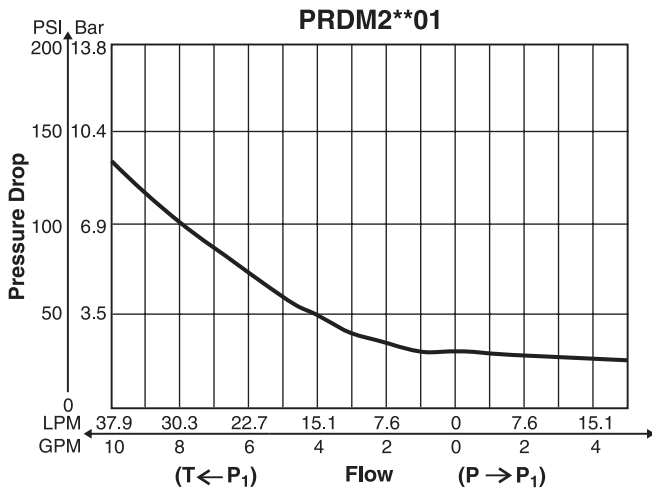

NOTE: Lowest pressure setting dependent upon system resistance.

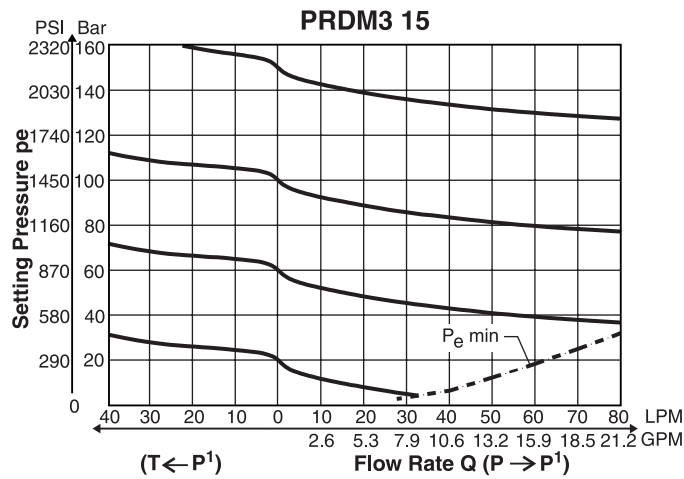
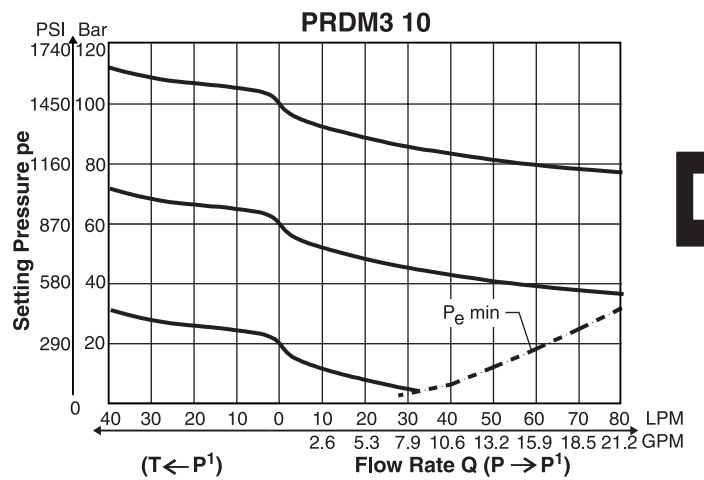
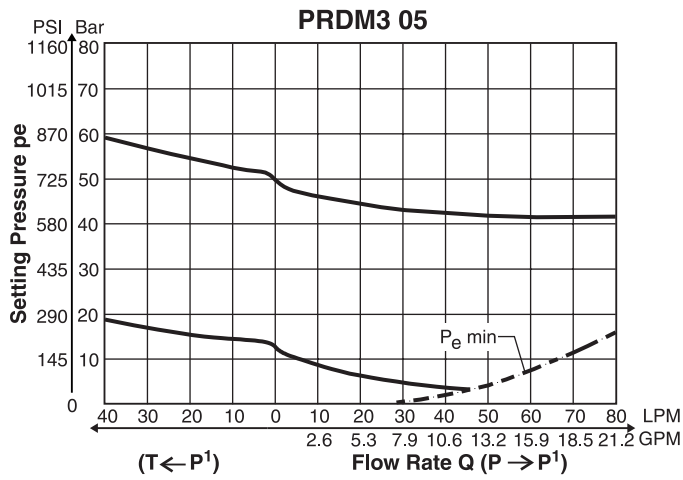

B

NOTE: Lowest pressure setting dependent upon system resistance.

PRDM2

Inch equivalents for millimeter dimensions are shown in (**)

B

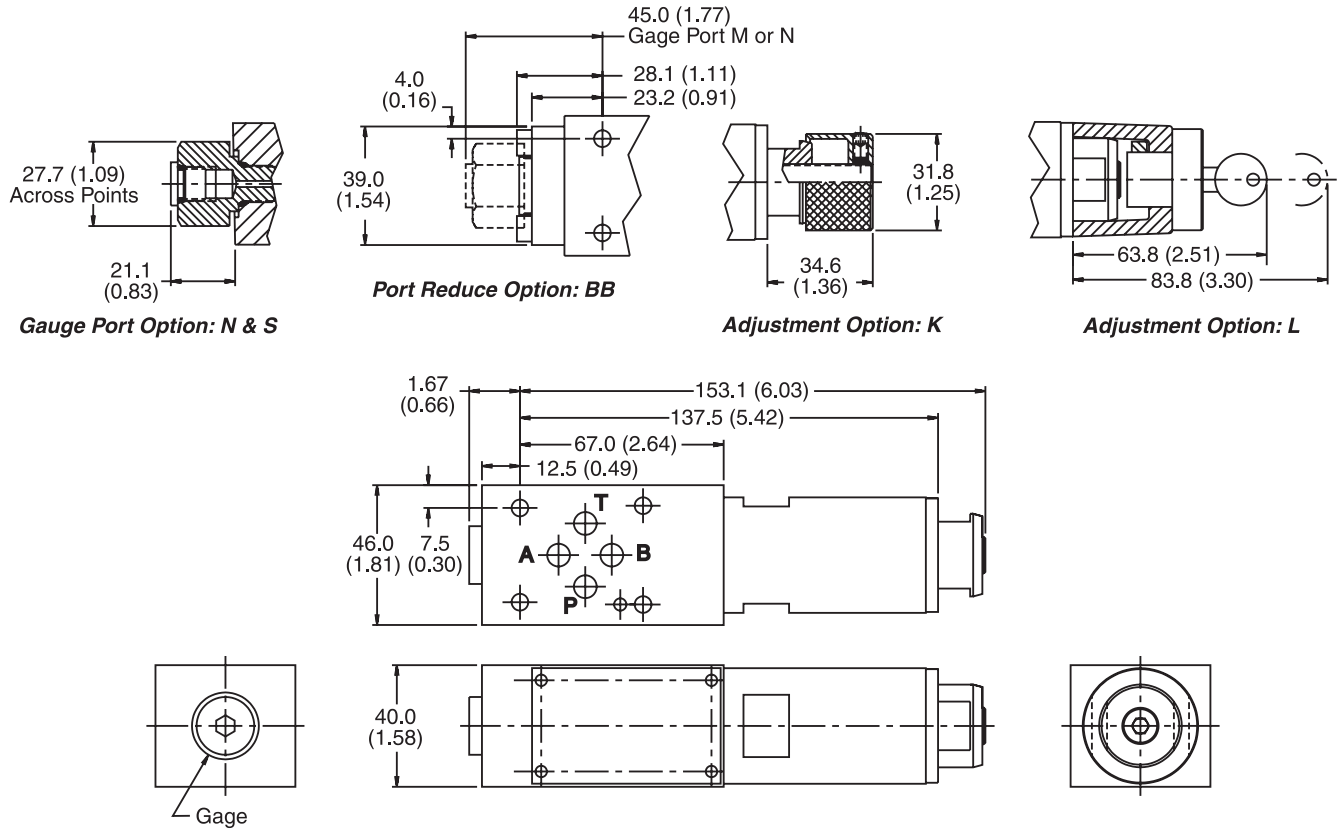

PRDM3

Inch equivalents for millimeter dimensions are shown in (**)

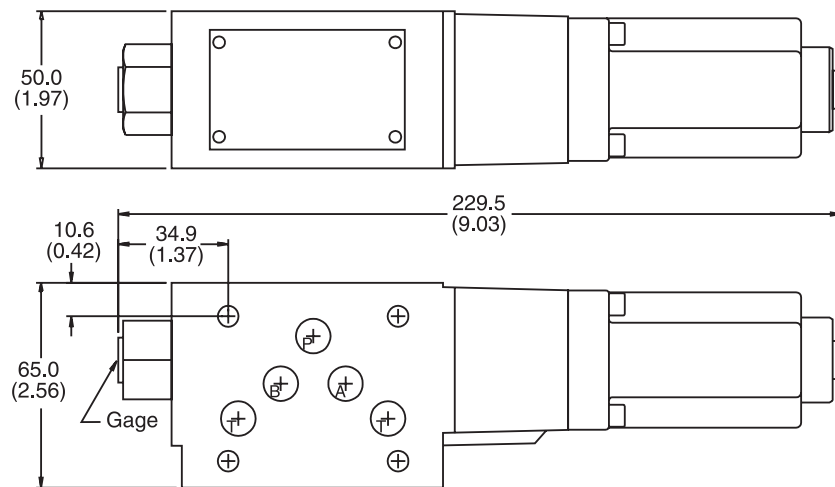

General Description

Series PRM reducing valves are used to regulate pressure, in one area of a circuit, below normal system pressure. This style valve is well suited to perform this function as it mounts directly below the directional control valve.

Operation

These are "normally open" valves that allow fluid to pass through the controlled port during typical operation. When downstream pressure rises above the value set by an adjustable spring force, the control pilot opens and allows the main spool to move from a full open position. The main spool modulates to maintain the desired "reduced pressure" downstream of the valve. The PRM3 also has a relieving mode.

Features

- PRM sandwich style pressure reducing valves can be used to reduce pressure on the 'P' port, the 'A' port, or the 'B' port.
- Three pressure adjustment options are available: slotted screw, knob and locking knob. (PRM6 only)
- Valve bodies are manufactured from steel which provide extra strength and durability for longer life. Internal hardened steel components also provide longer life.

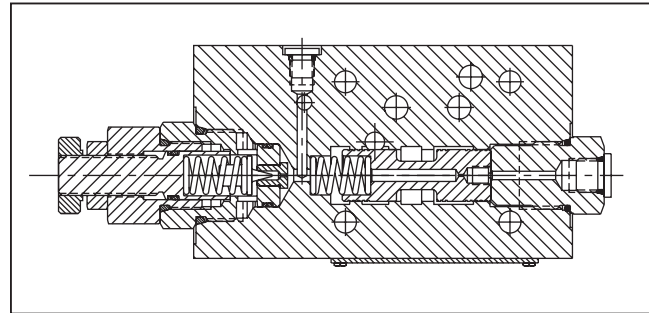
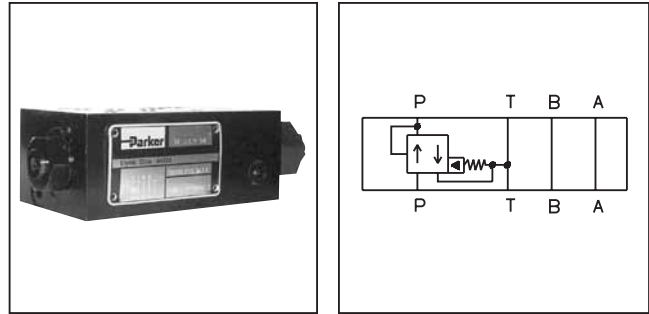

B

Specifications

	PRM3	PRM6		PRM3/PRM6										
Mounting Pattern	NFPA D05, CETOP 5, NG 10	NFPA D08, CETOP 8, NG 25	Filtration	ISO 4406 (1999); 18/16/13 (meet NAS 1638:7)										
Minimum Pressure	10 Bar (150 PSI) with rated flow, 150 SSU oil, and fluid temperature of 38°C (100°F). ¹		Venting	Connecting the vent port to tank allows the reducing valve to divert flow at minimum pressure.										
Maximum Pressure	345 Bar (5000 PSI)	345 Bar (5000 PSI)	Remote Control	Remote control valve connected to the vent port can be used to control the pressure. ²										
Min. Flow	3.78 LPM (1 GPM)	3.78 LPM (1 GPM)	Drain Line	Drain line from pilot valve is internally connected to the tank port. Tank line pressure is thus added to the valve setting. ³										
Maximum Flow	64 LPM (17 GPM)	189 LPM (50 GPM)												
Pressure Range	<table border="1"> <thead> <tr> <th>Code</th> <th>Pressure Range</th> </tr> </thead> <tbody> <tr> <td>07</td> <td>10 to 70 Bar (150 - 1000 PSI)</td> </tr> <tr> <td>17</td> <td>10 to 175 Bar (150 - 2500 PSI)</td> </tr> <tr> <td>25</td> <td>10 to 250 Bar (150 - 3500 PSI)</td> </tr> <tr> <td>35</td> <td>10 to 350 Bar (150 - 5000 PSI)</td> </tr> </tbody> </table>	Code	Pressure Range	07	10 to 70 Bar (150 - 1000 PSI)	17	10 to 175 Bar (150 - 2500 PSI)	25	10 to 250 Bar (150 - 3500 PSI)	35	10 to 350 Bar (150 - 5000 PSI)			
Code	Pressure Range													
07	10 to 70 Bar (150 - 1000 PSI)													
17	10 to 175 Bar (150 - 2500 PSI)													
25	10 to 250 Bar (150 - 3500 PSI)													
35	10 to 350 Bar (150 - 5000 PSI)													

¹ Change in flow, temperature or fluid (SSU) rating will affect valve minimum pressure.
² Set main valve pressure 10 Bar (150 PSI) higher than remote pilot.
³ It is important that the drain line connection be taken into consideration when determining the minimum valve setting.

B

PRM

Pressure Reducing Valve

Size

Port Reduction

Pressure Range

Adjustment

Seal

Gauge Port

Drain

Design Series

NOTE:
 Not required when ordering.

Code	Description
3	NFPA D05 Subplate Mounting
6	NFPA D08 Subplate Mounting

Code	Description	Available Models	
		PRM3	PRM6
PP	P Port Only	✓	
AA	A Port Only	✓	
BB	B Port Only	✓	✓
PA	P Port Reduced/Convertible to A Port Reduced		✓
AP	A Port Reduced/Convertible to P Port Reduced		✓

Code	Description
07	10 to 70 Bar (150 to 1000 PSI)
17	10 to 175 Bar (150 to 2500 PSI)
25	10 to 250 Bar (150 to 3500 PSI)
35	10 to 345 Bar (150 to 5000 PSI)

Code	Type
N	Nitrile
V	Fluorocarbon

Code	Type
K	Knob
L*	Locking Knob
S	Screw Adj.

* PRM6 only.

Code	Type
Omit*	SAE
S†	SAE
N†	NPT
M†	Metric
G	1/4 BSPP

* PRM6 only.
 † PRM3 only.

Code	Type
Omit	Internal
Y	External

Unit Weight:

PRM3 3.0 kg (6.6 lbs.)
 PRM6 5.6 kg (12.5 lbs.)

Bold: Designates Tier I products and options.

Non-Bold: Designates Tier II products and options.
 These products will have longer lead times.

Bolt Kits

Size "3"				Size "6"			
No. of Sandwich	Sandwich & Valve Combination	D3W-30 D31*W* Bolt Length mm (in)		No. of Sandwich	Sandwich & Valve Combination	Bolt Kit	Bolt Length mm (in)
1	Sandwich & D3	BK141 88.9 (3.50)		1	Sandwich & D6	BK121	133.4 (5.25)
2	Sandwich & D3	BK142 139.7 (5.50)		2	Sandwich & D6	BK122	203.2 (8.00)
3	Sandwich & D3	BK143 190.5 (7.50)		3	Sandwich & D6	BK123	273.1 (10.75)
				4	Sandwich & D6	BK124	342.9 (13.5)

* D31VW with internal pilot and internal drain only.

Bolt Kits must be ordered separately.

Schematics

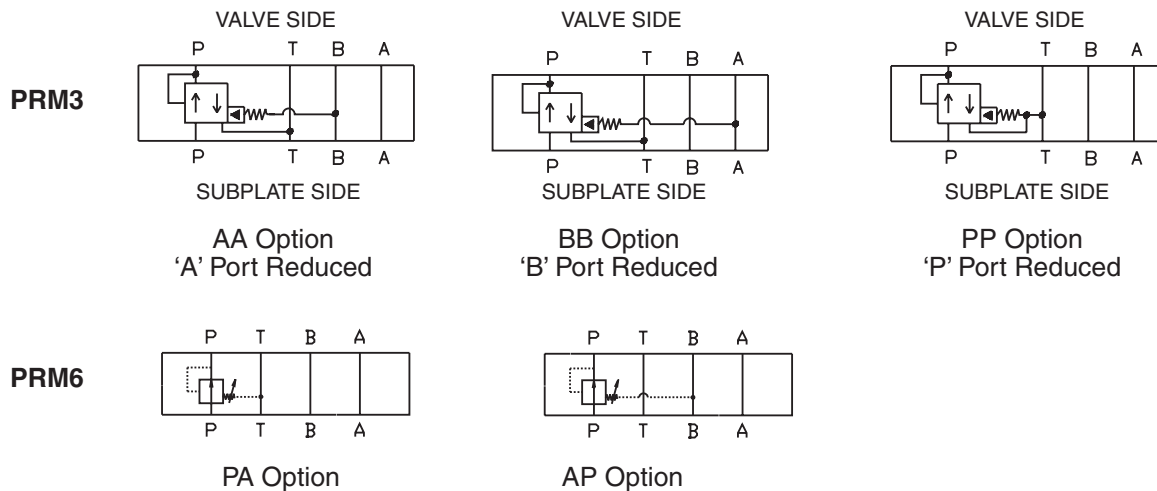

Parker Sandwich.indd, dd

Performance Curves

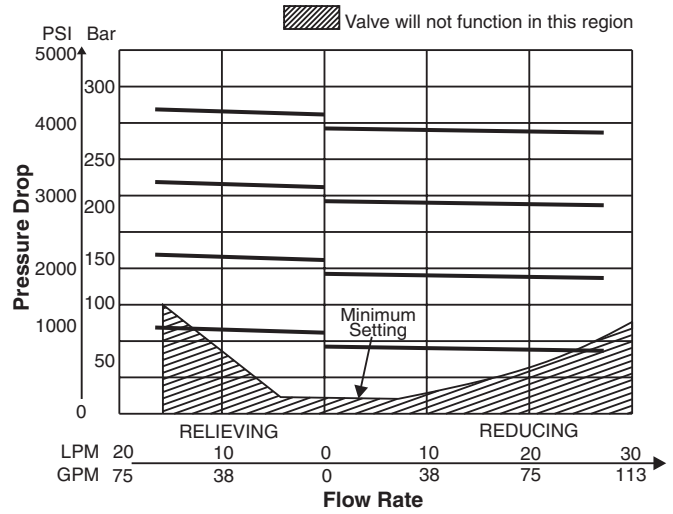
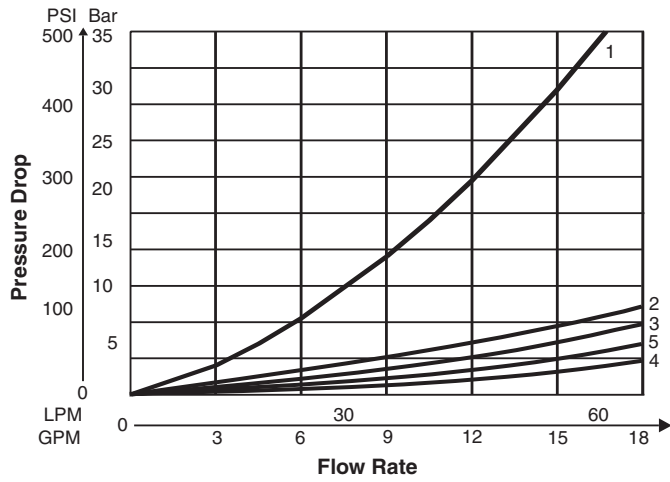

B

Mode	Flow Path			
	P → P	A → A	B → B	T → T
PP	1	2	3	4
AA	1	2	3	5
BB	1	2	3	5

Viscosity Correction Factor							
Viscosity (SSU)	75	150	200	250	300	350	400
% of ΔP (approx.)	93	111	119	126	132	137	141
Curves were generated using 100 SSU hydraulic oil. For any other viscosity, pressure drop will change per chart.							

NOTE: Lowest pressure setting dependent upon system resistance.

PRM3AA

Inch equivalents for millimeter dimensions are shown in (**)

B

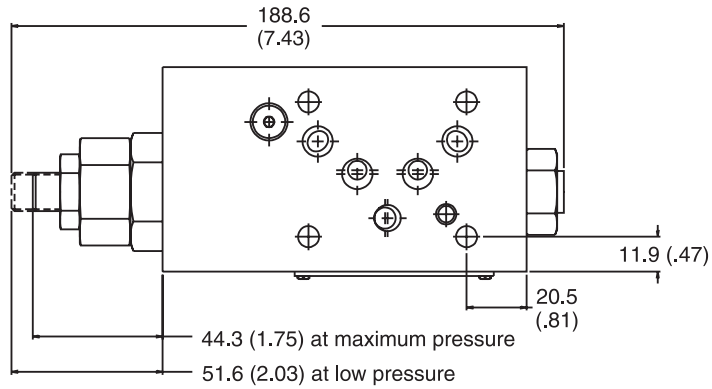

Top View

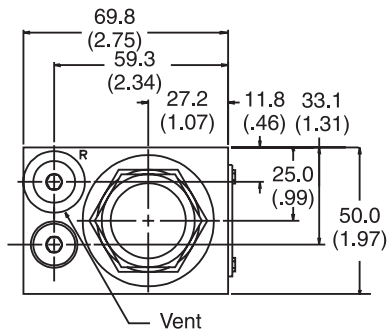

End View

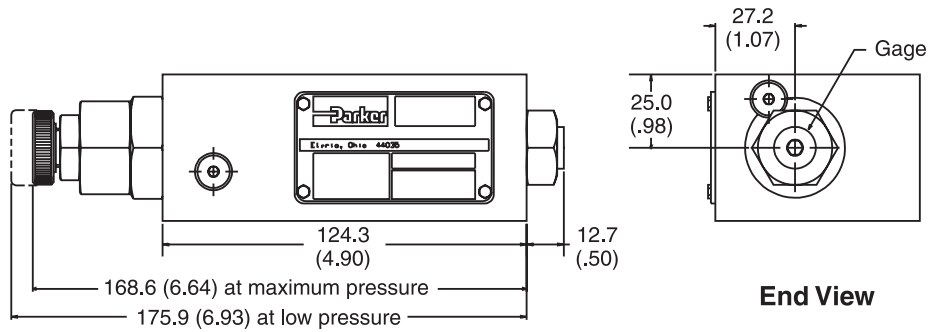

Face View

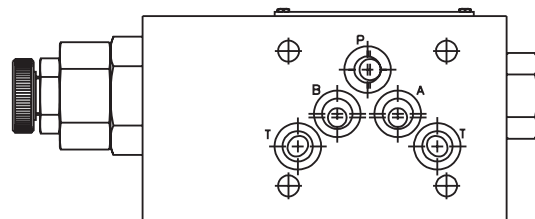

Bottom View



PRM3BB

Inch equivalents for millimeter dimensions are shown in (**)

B

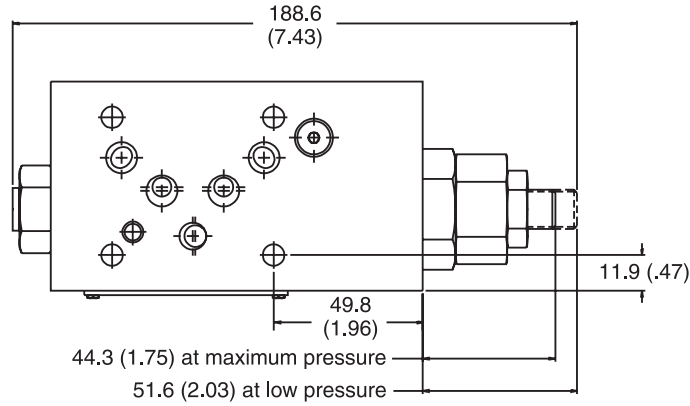

Top View

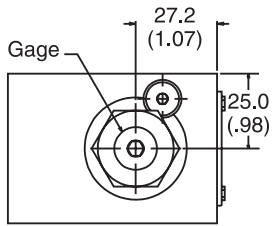

End View

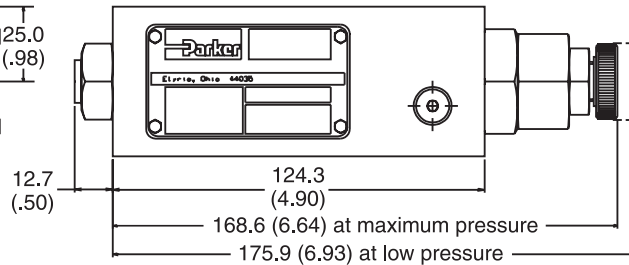

Face View

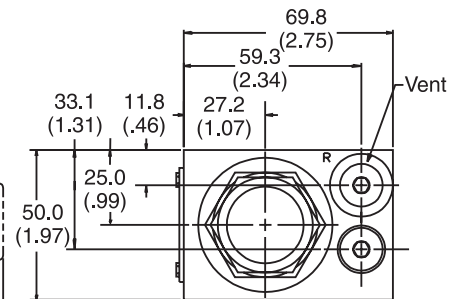

End View

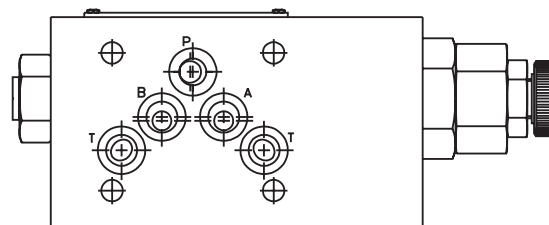

Bottom View



PRM3PP

Inch equivalents for millimeter dimensions are shown in (**)

B

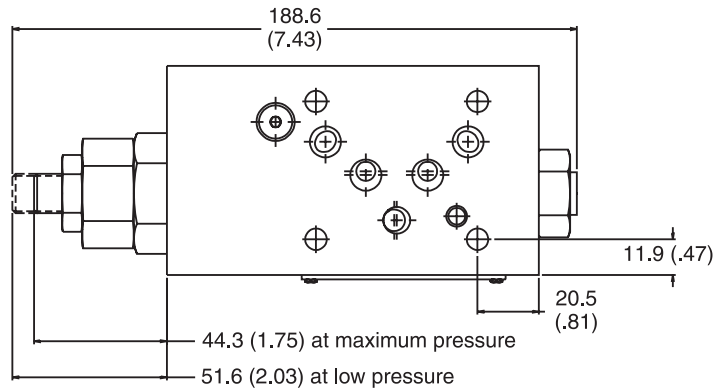

Top View

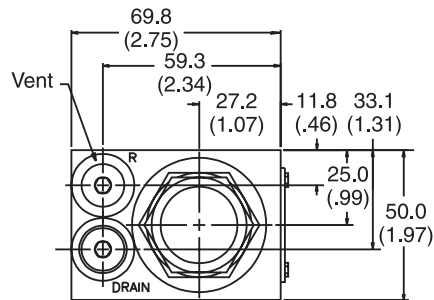

End View

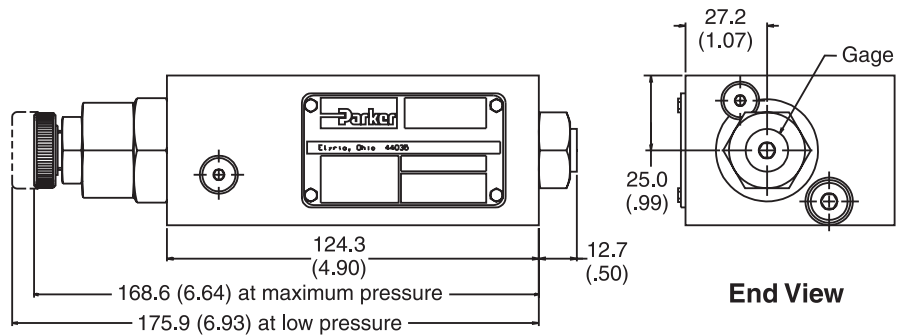

Face View

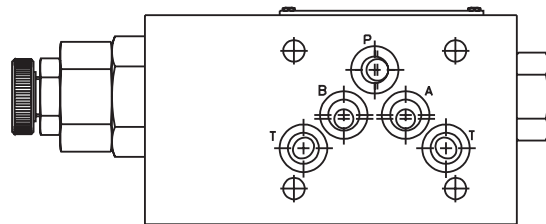

Bottom View



Inch equivalents for millimeter dimensions are shown in (**)

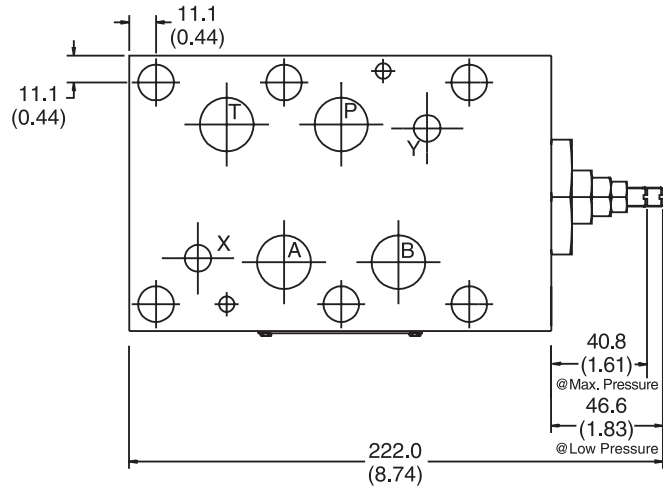

Top View

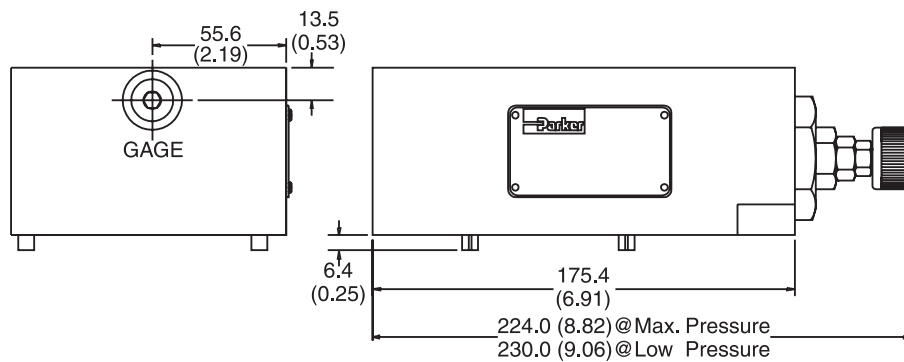

Face View

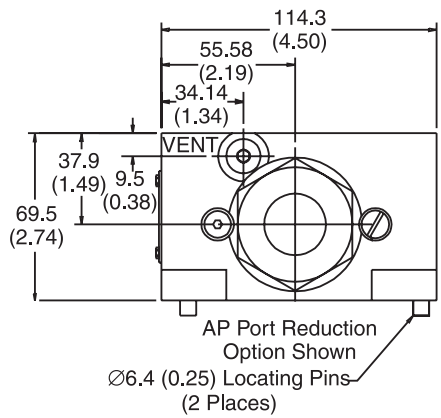

End View

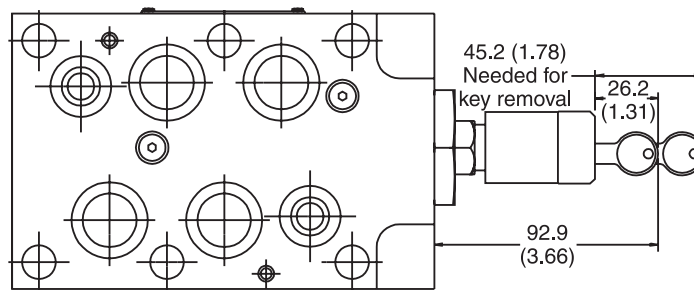

Bottom View

B



General Description

Series RM relief valves limit system pressure by opening to tank when system pressure reaches the valve setting. With D03 size, they can also be configured to limit the 'A' or 'B' work port pressures independently.

B

Features

- RM sandwich style relief valves can be used to limit pressure in the 'P' port, 'A' port, or 'B' port.
- Valve bodies are manufactured from steel which provide extra strength and durability for longer life. Internal hardened steel components also provide longer life.
- Three pressure adjustment options are available: slotted screw, knob and locking knob.
- SAE Gage Port

Specifications

	RM2	RM3	RM6										
Mounting Pattern	NFPA D03, CETOP 3, NG 6	NFPA D05, CETOP 5, NG 10	NFPA D08, CETOP 8, NG 25										
Minimum Pressure	10 Bar (150 PSI) with rated flow, 150 SSU oil, and fluid temperature of 38°C (100°F). ¹												
Maximum Pressure	350 Bar (5000 PSI)	350 Bar (5000 PSI)	350 Bar (5000 PSI)										
Minimum Flow	3.78 LPM (1 GPM)	3.78 LPM (1 GPM)	3.78 LPM (1 GPM)										
Maximum Flow	53 LPM (14 GPM)	76 LPM (20 GPM)	341 LPM (90 GPM)										
Pressure Range	<table border="1"> <thead> <tr> <th>Code</th> <th>Pressure Range</th> </tr> </thead> <tbody> <tr> <td>07</td> <td>10 to 70 Bar (150 - 1000 PSI)</td> </tr> <tr> <td>17</td> <td>10 to 175 Bar (150 - 2500 PSI)</td> </tr> <tr> <td>25</td> <td>10 to 250 Bar (150 - 3500 PSI)</td> </tr> <tr> <td>35</td> <td>10 to 350 Bar (150 - 5000 PSI)</td> </tr> </tbody> </table>			Code	Pressure Range	07	10 to 70 Bar (150 - 1000 PSI)	17	10 to 175 Bar (150 - 2500 PSI)	25	10 to 250 Bar (150 - 3500 PSI)	35	10 to 350 Bar (150 - 5000 PSI)
Code	Pressure Range												
07	10 to 70 Bar (150 - 1000 PSI)												
17	10 to 175 Bar (150 - 2500 PSI)												
25	10 to 250 Bar (150 - 3500 PSI)												
35	10 to 350 Bar (150 - 5000 PSI)												
Filtration	ISO 4406 (1999); 18/16/13 (meet NAS 1638:7)												
Venting	Connecting the vent port to tank allows the relief valve to divert flow at minimum pressure. ²												
Remote Control	Remote control valve connected to the vent port can be used to control the pressure. ³												

¹ Change in flow, temperature or fluid (SSU) rating will affect valve minimum pressure.

² Not available on Model RM2.

³ Set main valve pressure 10 Bar (150 PSI) higher than remote pilot.

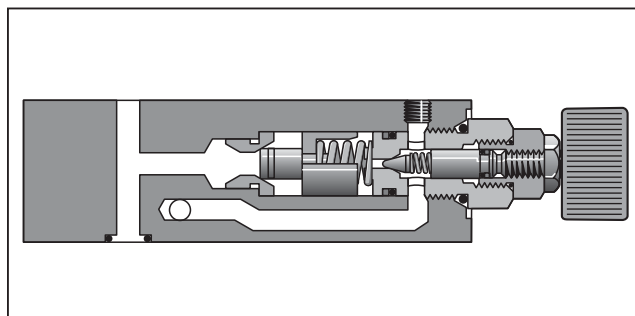
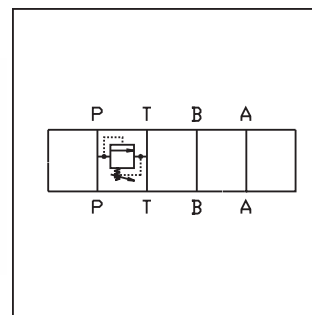

Performance Curves

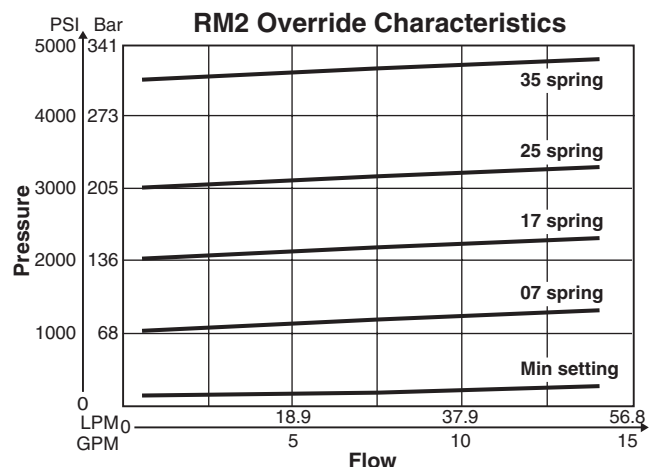

VISCOSITY CORRECTION FACTOR							
Viscosity (SSU)	75	150	200	250	300	350	400
% of ΔP (Approx.)	93	111	119	126	132	137	141

Curves were generated using 100 SSU hydraulic oil. For any other viscosity, pressure drop will change per chart.

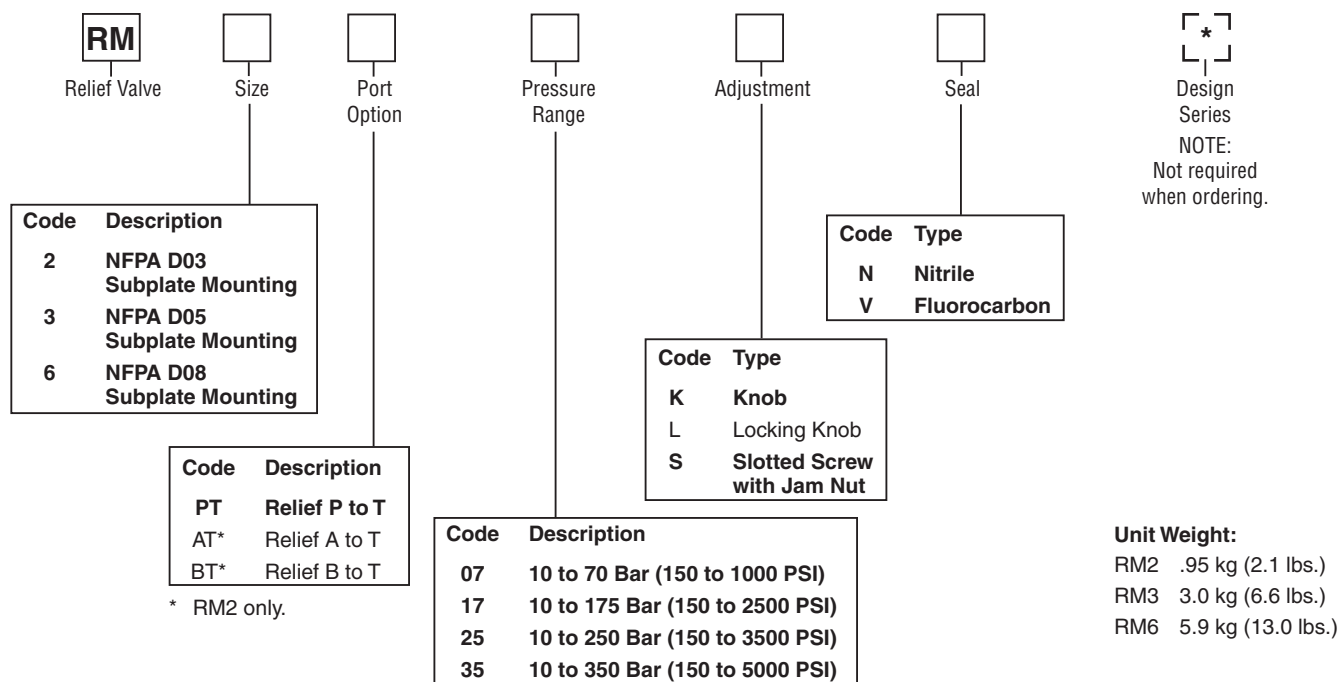

Bold: Designates Tier I products and options.

Non-Bold: Designates Tier II products and options. These products will have longer lead times.

Bolt Kits

Size "2"				Size "3"			
No. of Sandwich	Sandwich & Valve Combination	Bolt Kit	Bolt Length mm (in)	No. of Sandwich	Sandwich & Valve Combination	D3W-30 D3DW & D31*W*	Bolt Length mm (in)
1	Sandwich & D1	BK243	73.2 (2.88)	1	Sandwich & D3	BK141	88.9 (3.50)
2	Sandwich & D1	BK225	111.3 (4.38)	2	Sandwich & D3	BK142	139.7 (5.50)
3	Sandwich & D1	BK244	152.4 (6.00)	3	Sandwich & D3	BK143	190.5 (7.50)
4	Sandwich & D1	BK245	190.5 (7.50)				

* D31VW with internal pilot and internal drain only.

Size "6"			
No. of Sandwich	Sandwich & Valve Combination	Bolt Kit	Bolt Length mm (in)
1	Sandwich & D6	BK121	133.4 (5.25)
2	Sandwich & D6	BK122	203.2 (8.00)
3	Sandwich & D6	BK123	273.1 (10.75)
4	Sandwich & D6	BK124	342.9 (13.5)

Bolt Kits must be ordered separately.

Schematics

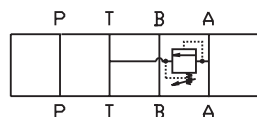

AT Option

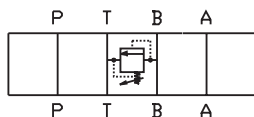

SUBPLATE SIDE
 BT Option

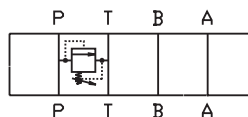

PT Option

B

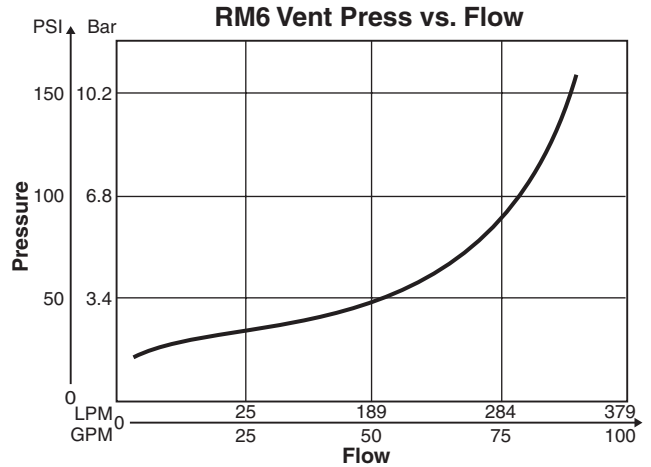
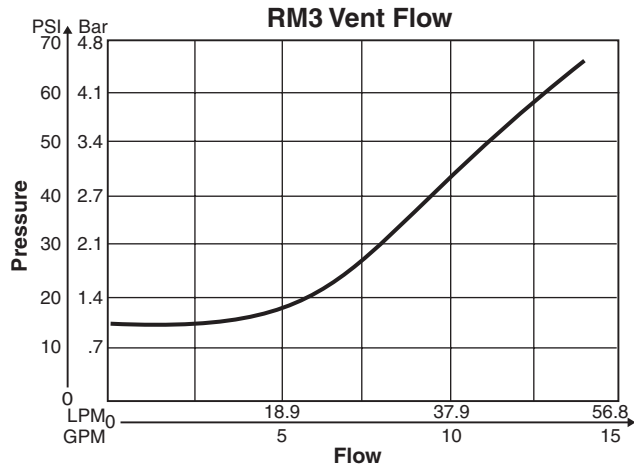
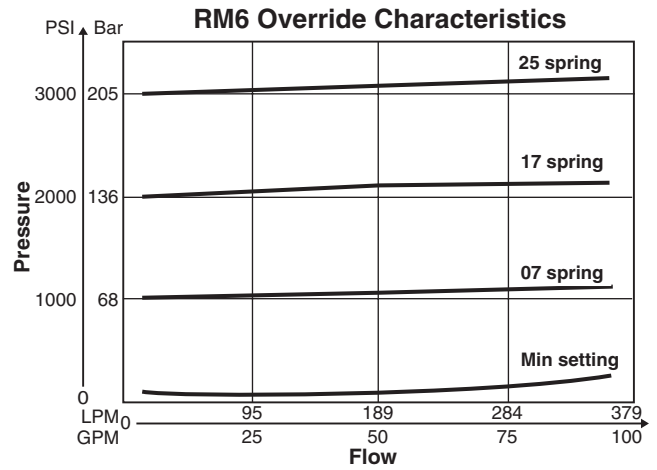
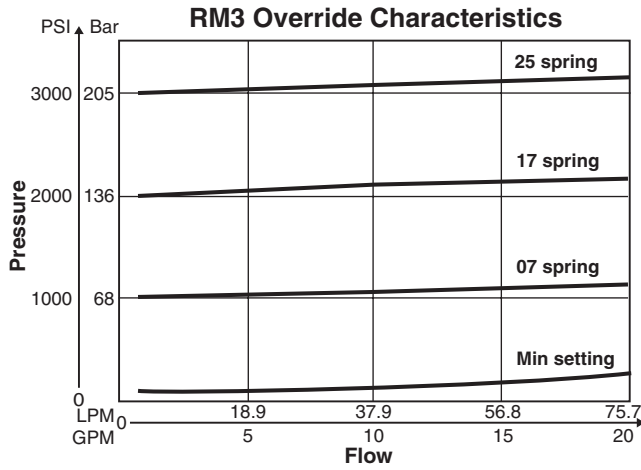

VISCOSITY CORRECTION FACTOR							
Viscosity (SSU)	75	150	200	250	300	350	400
% of ΔP (Approx.)	93	111	119	126	132	137	141
Curves were generated using 100 SSU hydraulic oil. For any other viscosity, pressure drop will change per chart.							

Inch equivalents for millimeter dimensions are shown in (**)

B

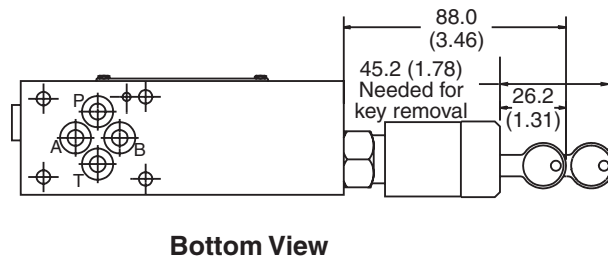
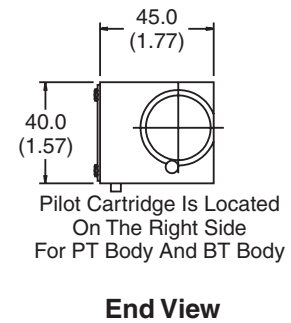
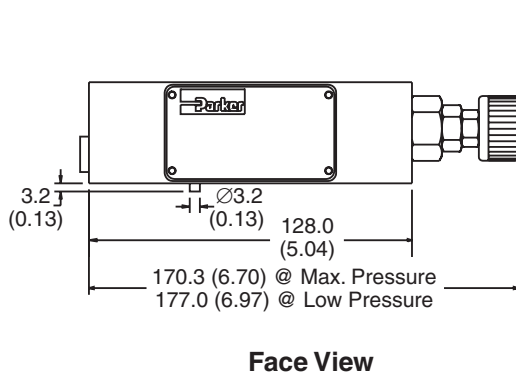
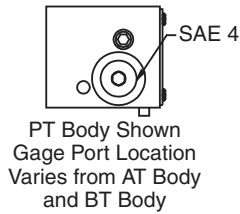
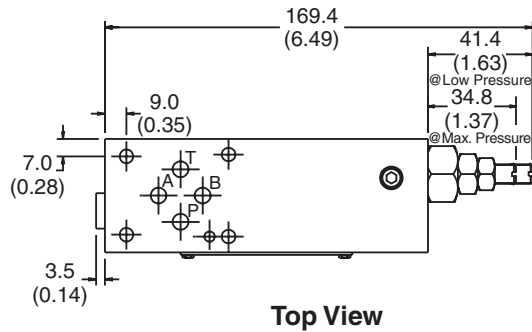

Inch equivalents for millimeter dimensions are shown in (**)

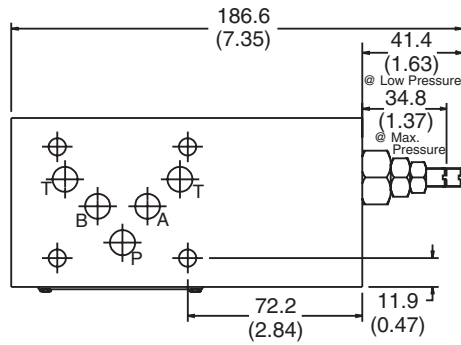

Top View

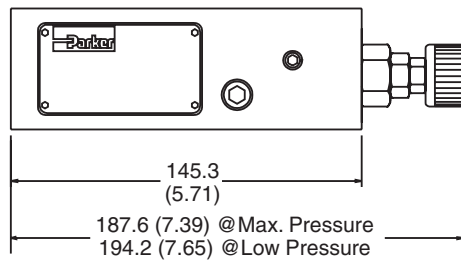
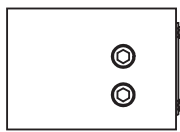

Face View

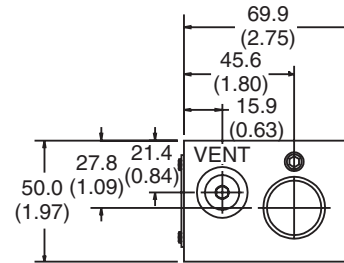

End View

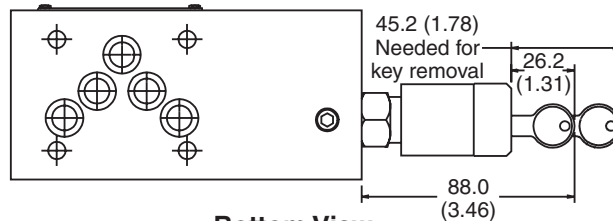

Bottom View

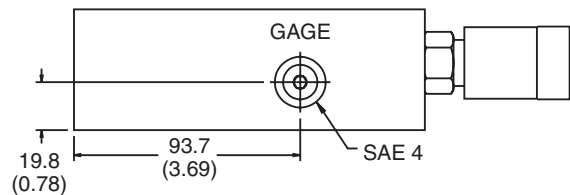

Back View



Inch equivalents for millimeter dimensions are shown in (**)

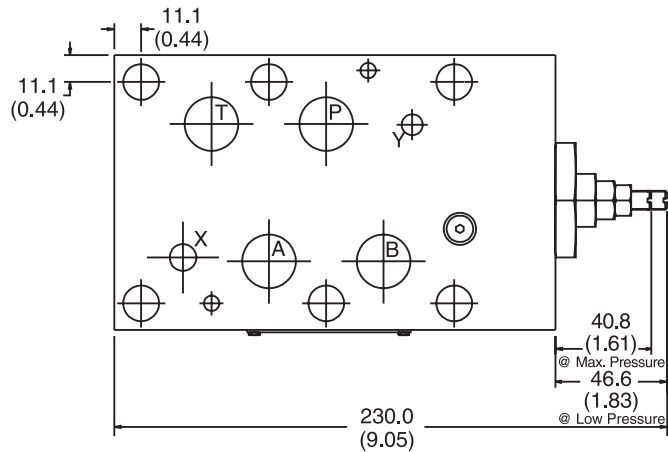

Top View

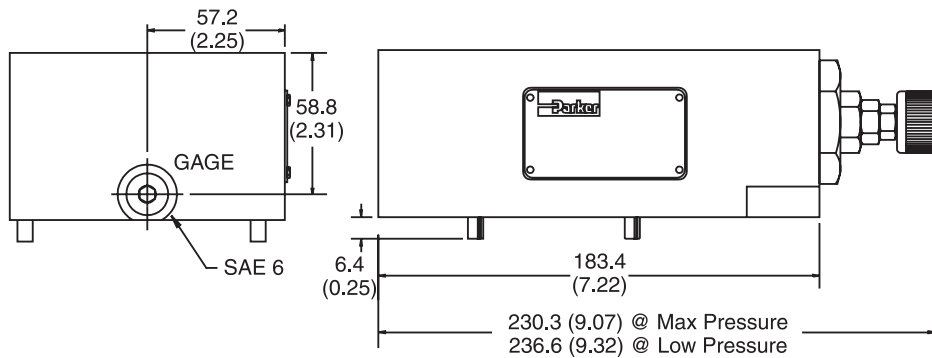

Face View

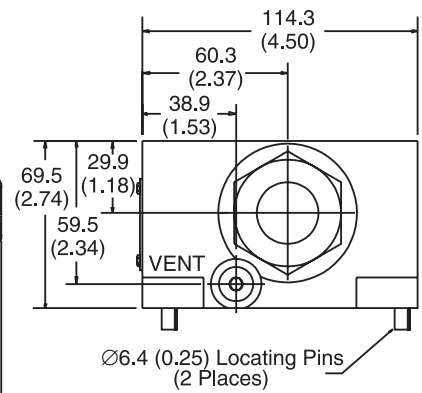

End View

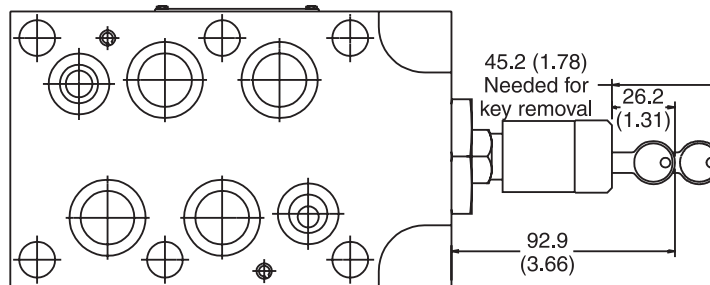

Bottom View

B



General Description

Series ZDR pilot operated pressure reducing valves are designed for maximum flow rates.

The reducing function can be located in the ports P, A or B. The sizes NG06 and NG10 are equipped with an integral return flow check valve (reducing function in A or B).

B



ZDR-P01

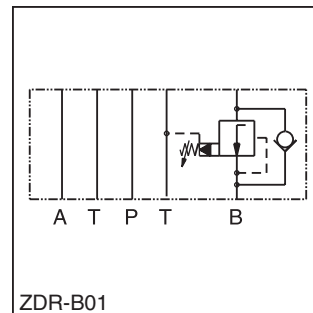

ZDR-B01

Features

- High flow capacity.
- Sizes::
 - ZDR01 – NFPA D03 / NG6 / CETOP 3
 - ZDR02 – NFPA D05 / NG10 / CETOP 5
- With integral return flow check valve.

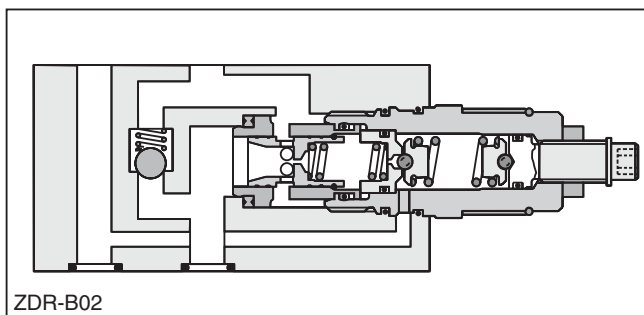

ZDR-B02

Specifications

General		
Size	NG6	NG10
Mounting Interface	DIN 24340 A6 ISO 4401 NFPA D03 CETOP RP 121	DIN 24340 A10 ISO 4401 NFPA D05 CETOP RP 121
Mounting Position	Unrestricted	
Ambient Temperature Range	-20°C to +50°C (-4°F to +122°F)	
Hydraulic		
Maximum Operating Pressure	up to 350 Bar (5075 PSI); ZDR-AR / BR up to 315 Bar (4568 PSI)	
Nominal Flow	80 LPM (21.2 GPM)	120 LPM (31.7 GPM)
Pilot Oil	0.2 LPM (0.1 GPM)	0.3 LPM (0.1 GPM)
Fluid	Hydraulic oil as per DIN 51524 ... 51525	
Fluid Temperature	-20°C to +80°C (-4°F to +176°F)	
Viscosity	Permitted	10 to 650 cSt / mm ² /s (46 to 3013 SSU)
	Recommended	30 cSt / mm ² /s (139 SSU)
Filtration	ISO Class 4406 (1999) 18/16/13 (acc. NAS 1638: 7)	

Ordering Information

ZDR Pressure Reducing Valve	Port Option	Size	Pressure Range	S0 Hexagon Screw with Lock Nut	D Design Series	Seal
---------------------------------------	-------------	------	----------------	--	---------------------------	------

Code	Description
01	NFPA D03 / NG6
02	NFPA D05 / NG10

Code	Description
1	up to 100 Bar (1450 PSI)
5*	up to 350 Bar (5075 PSI)

* AR/BR 325 Bar (4568 PSI)

Code	Size	Description
P	01/02	Pressure reducing in P with pressure gauge port M
AR	01/02	Pressure reducing in A with check valve
BR	01/02	Pressure reducing in B with check valve

Weight:	ZDR-P	ZDR-AR/BR
ZDR*01	1.6 kg (3.5 lbs.)	1.8 kg (4.0 lbs.)
ZDR*02	2.9 kg (6.4 lbs.)	3.0 kg (6.6 lbs.)



ZDR01

Pressure reducing in P with pressure gauge port M

Series
ZDRP011S0D1
ZDRP015S0D1

Pressure reducing in A with check valve

Series
ZDRAR011S0-D1
ZDRAR015S0-D1

Pressure reducing in B with check valve

Series
ZDRBR011S0D1
ZDRBR015S0D1

1 = 7 ... 140 Bar (102 ... 1450 PSI)
 5 = 7 ... 315 Bar (102 ... 4568 PSI)

ZDR02

Pressure reducing at P with pressure gauge port M

Series
ZDRP021S0D1
ZDRP025S0D1

Pressure reducing at A (with check valve)

Series
ZDRAR021S0D1
ZDRAR025S0D1

Pressure reducing at B (with check valve)

Series
ZDRBR021S0D1
ZDRBR025S0D1

Performance Curves

ZDR-P/AR/BR01

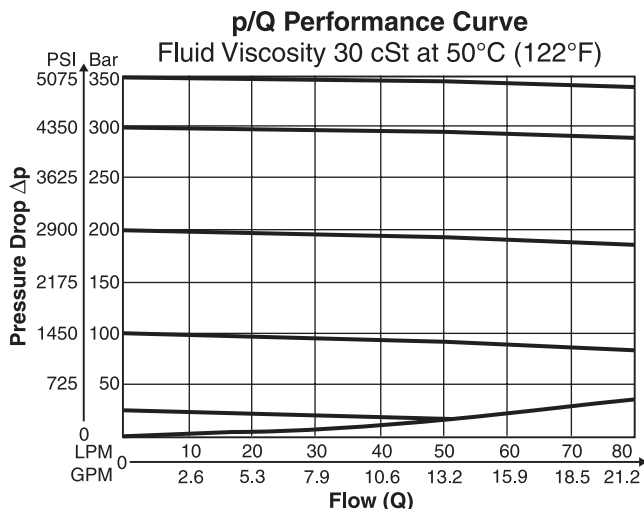

ZDR-P/AR/BR02

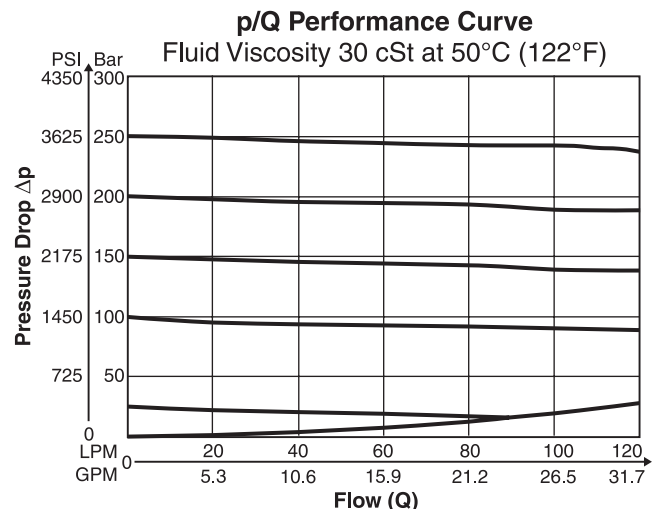

Denison Sandwich.indd, dd



ZDR01 – Inch equivalents for millimeter dimensions are shown in (**)

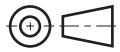
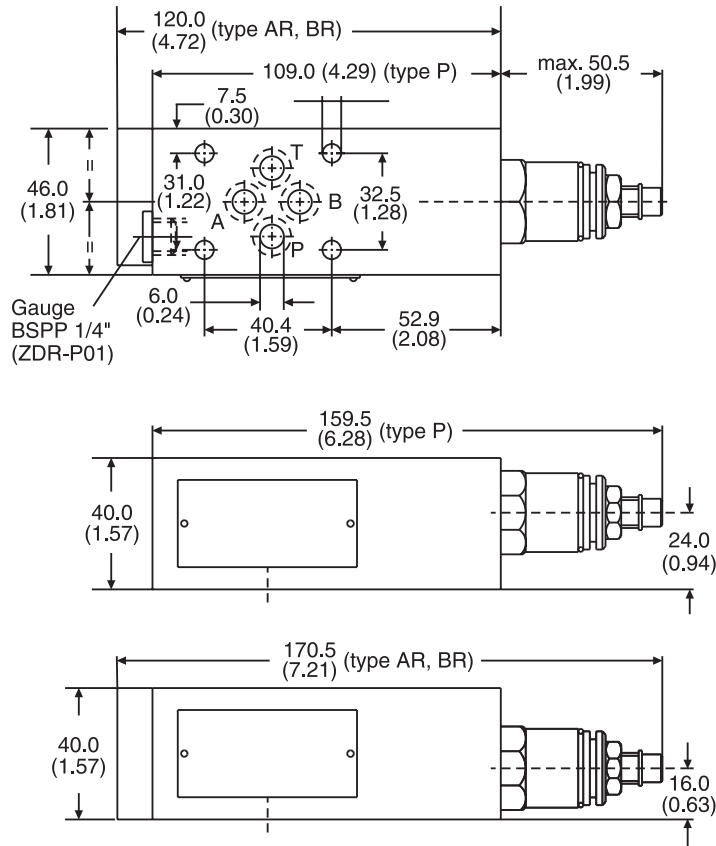

Seal Kit	
Seal	Order Code
1	098-91184-0
5	098-91185-0
Complete Cartridge	
Seal	Order Code
1	098-91102-0
5	098-91103-0

ZDR02 – Inch equivalents for millimeter dimensions are shown in (**)

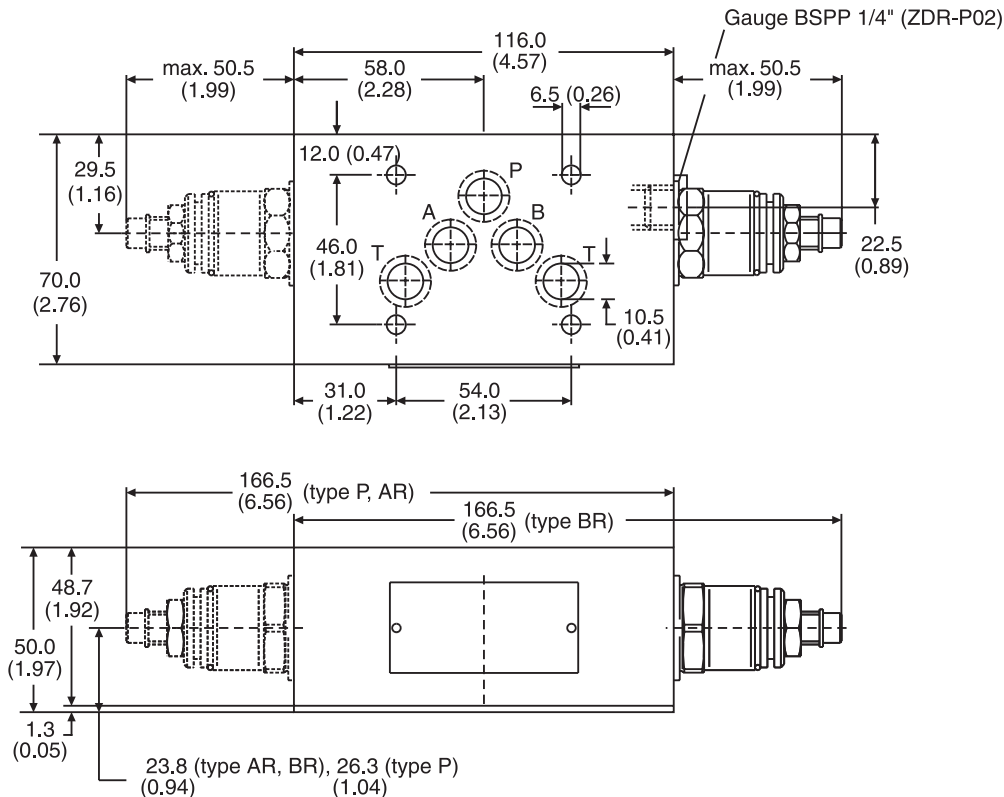

Seal Kit	
Seal	Order Code
1	098-91182-0
5	098-91183-0
Complete Cartridge	
Seal	Order Code
1	098-91102-0
5	098-91103-0

General Description

Series ZDV pilot operated pressure relief valves are designed for maximum flow rates.

The relief function can be located between P and T, A and T, B and T or A and T + B and T for typical pressure relief functions.

For a pre-charge function the ZDV can be ordered with pressure function between A and B + B and A.

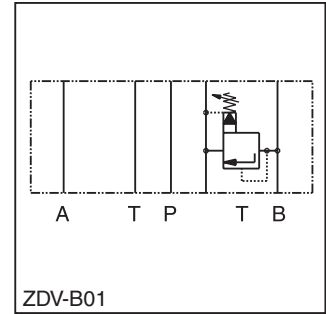

Features

- High flow capacity.
- Pressure function in P, A, B or A + B.
- Sizes:
 - ZDV01 – NFPA D03 / NG6 / CETOP 3
 - ZDV02 – NFPA D05 / NG10 / CETOP 5

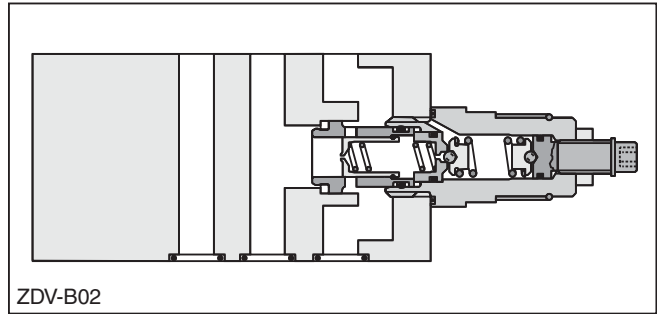

Ordering Information

ZDV	□	□	□	S0	D	□																		
Pressure Relief Valve	Port Option	Size	Pressure Range	Hexagon Screw with Lock Nut	Design Series	Seal																		
		<table border="1" style="width: 100%; border-collapse: collapse;"> <thead> <tr> <th>Code</th> <th>Description</th> </tr> </thead> <tbody> <tr> <td>01</td> <td>NFPA D03 / NG6</td> </tr> <tr> <td>02</td> <td>NFPA D05 / NG10</td> </tr> </tbody> </table>	Code	Description	01	NFPA D03 / NG6	02	NFPA D05 / NG10	<table border="1" style="width: 100%; border-collapse: collapse;"> <thead> <tr> <th>Code</th> <th>Description</th> </tr> </thead> <tbody> <tr> <td>1</td> <td>up to 70 Bar (1015 PSI)</td> </tr> <tr> <td>5*</td> <td>up to 350 Bar (5075 PSI)</td> </tr> </tbody> </table> <p>* ABS 315 Bar (4568 PSI)</p>	Code	Description	1	up to 70 Bar (1015 PSI)	5*	up to 350 Bar (5075 PSI)			<table border="1" style="width: 100%; border-collapse: collapse;"> <thead> <tr> <th>Code</th> <th>Description</th> </tr> </thead> <tbody> <tr> <td>1</td> <td>Nitrile</td> </tr> <tr> <td>5</td> <td>Fluorocarbon</td> </tr> </tbody> </table>	Code	Description	1	Nitrile	5	Fluorocarbon
Code	Description																							
01	NFPA D03 / NG6																							
02	NFPA D05 / NG10																							
Code	Description																							
1	up to 70 Bar (1015 PSI)																							
5*	up to 350 Bar (5075 PSI)																							
Code	Description																							
1	Nitrile																							
5	Fluorocarbon																							

Code	Size	Description
P	01/02	P – T
A	01/02	A – T
B	01/02	B – T
AB	01/02	A – T & B – T
ABS	01/02	A – B & B – A

Weight:	One Cartridge	Two Cartridges
ZDV*01	1.6 kg (3.5 lbs.)	2.5 kg (5.5 lbs.)
ZDV*02	3.0 kg (6.6 lbs.)	3.7 kg (8.2 lbs.)



Ordering Information

ZDV01

Pressure control P-T

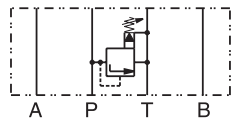

Series
 ZDVP011S0D1
 ZDVP015S0D1

Pressure control A-T

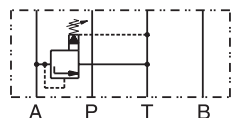

Series
 ZDVA011S0D1
 ZDVA015S0D1

Pressure control B-T

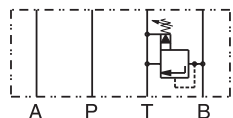

Series
 ZDVB011S0D1
 ZDVB015S0D1

1 = 7 ... 70 Bar (102 ... 1015 PSI)
 5 = 7 ... 350 Bar (102 ... 5075 PSI)

Pressure control A-T & B-T

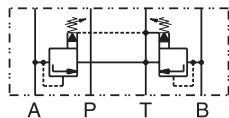

Series
 ZDVAB011S0D1
 ZDVAB015S0D1

Pressure control A-B & B-A

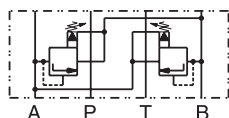

Series
 ZDVABS011S0D1
 ZDVABS015S0D1

1 = 7 ... 70 Bar (102 ... 1015 PSI)
 5 = 7 ... 315 Bar (102 ... 4568 PSI)

ZDV02

Pressure control P-T

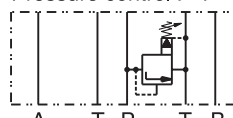

Series
 ZDVP021S0D1
 ZDVP025S0D1

Pressure control A-T

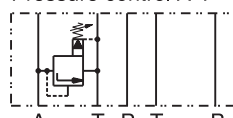

Series
 ZDVA021S0D1
 ZDVA025S0D1

Pressure control B-T



Series
 ZDVB021S0D1
 ZDVB025S0D1

Pressure control A-T & B-T

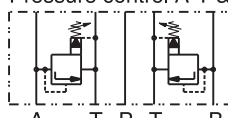

Series
 ZDVAB021S0D1
 ZDVAB025S0D1

Pressure control A-B & B-A

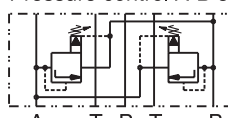

Series
 ZDVABS021S0D1
 ZDVABS025S0D1

Specifications

General		NG6	NG10
Size			
Mounting		DIN 24340 A6 ISO 4401 NFPA D03 CETOP RP 121	DIN 24340 A10 ISO 4401 NFPA D05 CETOP RP 121
Mounting Position		Unrestricted	
Ambient Temperature Range		-20° to +50°C (-4°F to +122°F)	
Hydraulic			
Maximum Operating Pressure		up to 350 Bar (5075 PSI); ZDV*ABS up to 315 Bar (4568 PSI)	
Nominal Flow		80 LPM (21.2 GPM)	140 LPM (37.0 GPM)
Fluid		Hydraulic oil as per DIN 51524 ... 51525	
Fluid Temperature		-20° to +80°C (-4°F to +176°F)	
Viscosity	Permitted Recommended	10 to 650 cSt / mm ² /s (46 to 3013 SSU) 30 cSt / mm ² /s (139 SSU)	
Filtration		ISO Class 4406 (1999) 18/16/13 (acc. NAS 1638: 7)	

Denison Sandwich.indd, dd



ZDV-P/A/B/ABS01

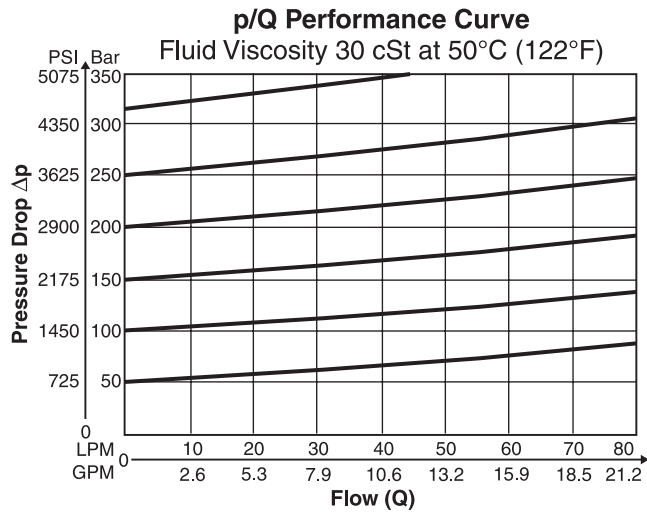

ZDV-AB01

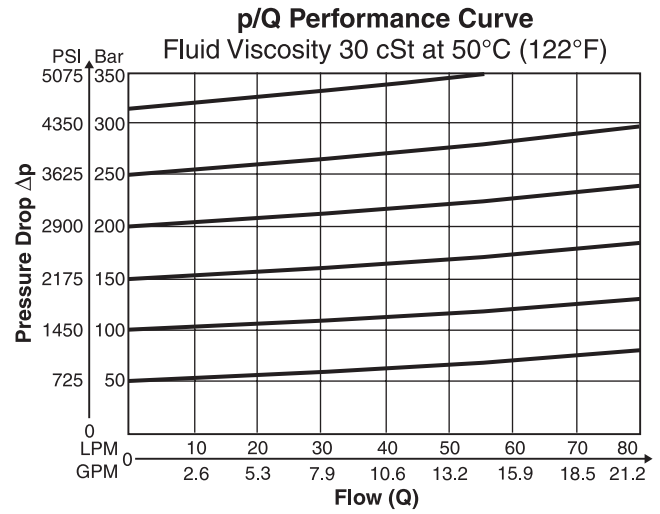

B

ZDV-P/A/B/AB02

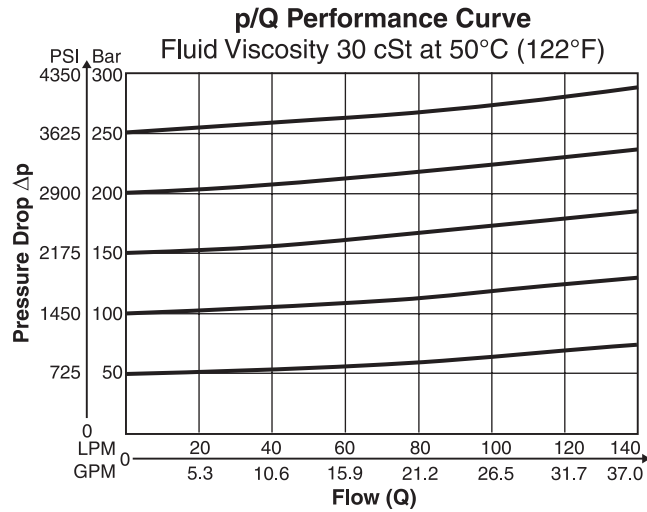

ZDV-ASB02

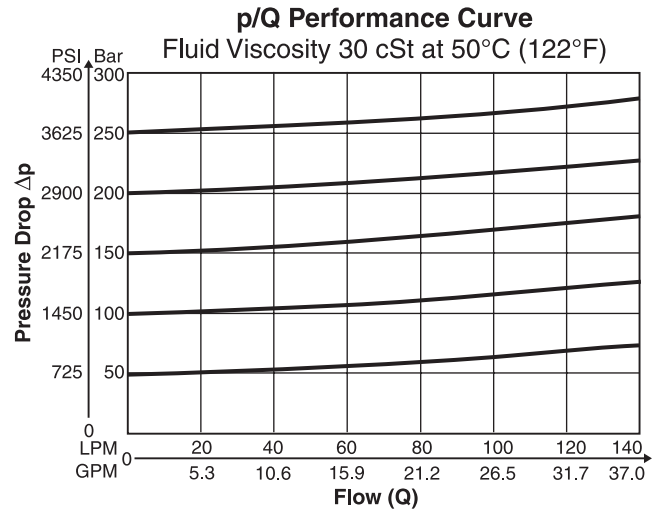

ZDV01 – Inch equivalents for millimeter dimensions are shown in (**)

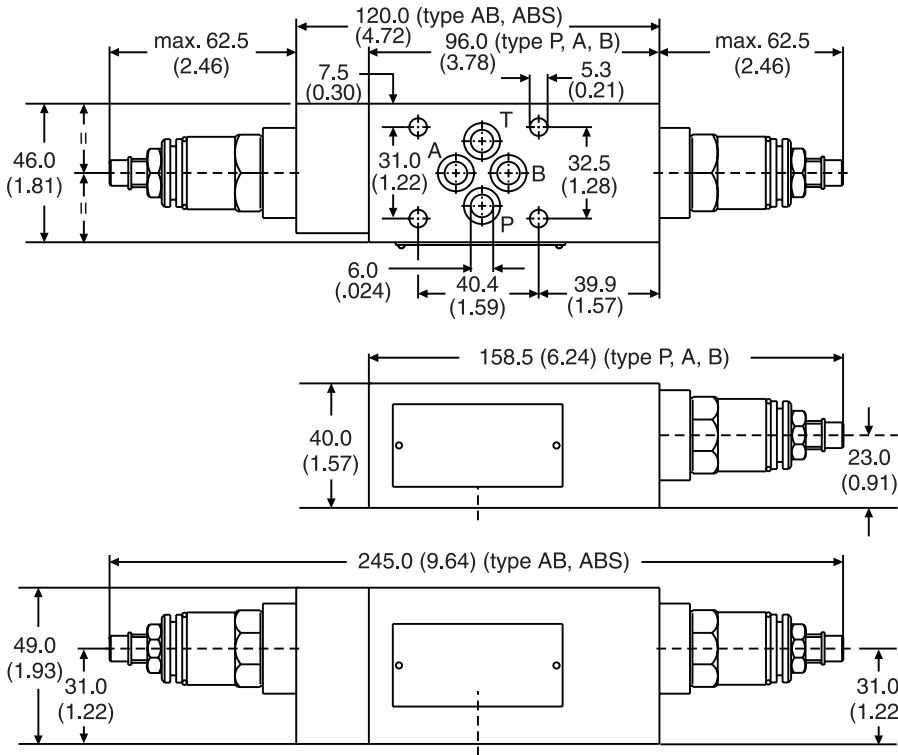

Seal Kit	
Seal	Order Code
1	098-91182-0
5	098-91183-0
Complete Cartridge	
Seal	Order Code
1	098-91116-0
5	098-91117-0

ZDV02 – Inch equivalents for millimeter dimensions are shown in (**)

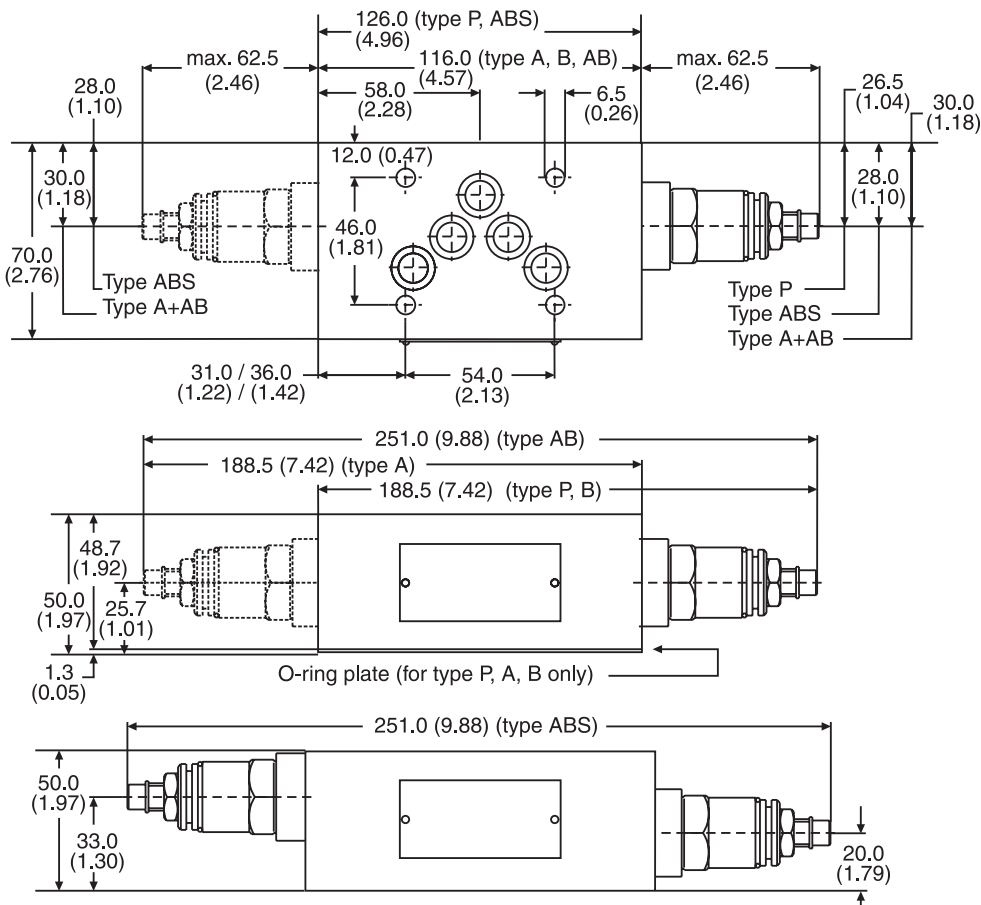

Seal Kit	
Seal	Order Code
1	098-91076-0
5	098-91077-0
Complete Cartridge	
Seal	Order Code
1	098-91116-0
5	098-91117-0

General Description

Series ZNS counterbalance valve controls the actuator movement at overrunning loads.

The return flow from the actuator is piloted and controlled by the inlet flow to the actuator, ensuring a cavitation-free lowering of the load.

The counterbalance valve operates as a pressure relief valve. The setting pressure is lowered by the pressure in the inlet line. To ensure safe load holding the setting pressure should be approximately 30% higher than the max. load pressure.

Features

- Controlled movement loads.
- Load holding via leak-free poppet valve.
- Secondary relief protection for the actuator.
- Sizes:
 ZNS*01 – NFPA D03 / NG6 / CETOP 3
 ZNS*02 – NFPA D05 / NG10 / CETOP 5

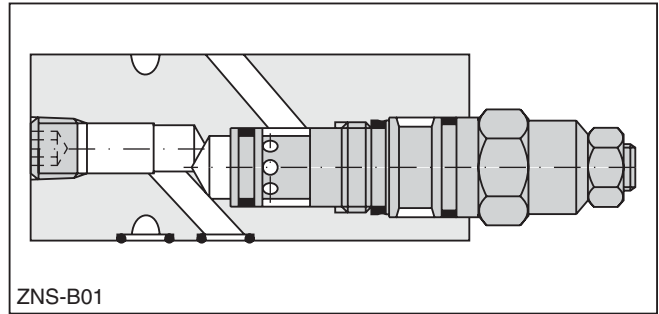
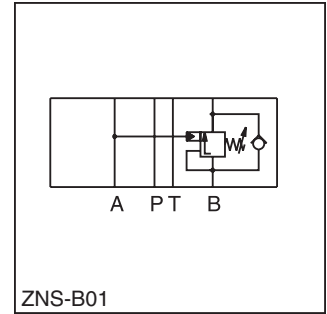

B

Ordering Information

ZNS					S0	D		
Counterbalance Valve		Port Option	Size	Pressure Range	Hexagon Screw with Lock Nut	Design Series	Seal	
Code	Description	Code	Description	Code	Description	Code	Description	
A	in A	01	NFPA D03 / NG6	2	70 to 175 Bar (1015 to 2538 PSI)		1	Nitrile
B	in B	02	NFPA D05 / NG10	5 ¹⁾	140 to 350 Bar (2030 to 5075 PSI)		5	Fluorocarbon
AB	in A and B							

¹⁾ ZNS02 to 315 Bar (4568 PSI)

Weight:	1 cartridge	2 cartridges
ZNS*01	1.3 kg (2.9 lbs.)	3.0 kg (6.6 lbs.)
ZNS*02	1.6 kg (3.5 lbs.)	3.9 kg (8.6 lbs.)

ZNS01

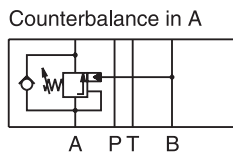

Series
 ZNSA012S0D1
 ZNSA015S0D1

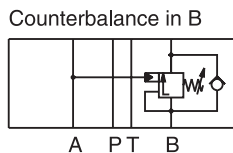

Series
 ZNSB011S0D1
 ZNSB015S0D1

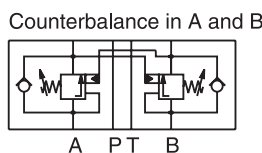

Series
 ZNSAB011S0D1
 ZNSAB015S0D1

2 = 70 ... 175 Bar (1015 ... 2538 PSI)
 5 = 140 ... 350 Bar (2030 ... 5075 PSI)

ZNS02

Series
 ZNSA022S0D1
 ZNSA025S0D1

Series
 ZNSB021S0D1
 ZNSB025S0D1

Series
 ZNSAB021S0D1
 ZNSAB025S0D1

2 = 70 ... 175 Bar (1015 ... 2538 PSI)
 5 = 140 ... 315 Bar (2030 ... 4568 PSI)

Specifications

General		
Size	NG6	NG10
Mounting Interface	DIN 24340 A6 ISO 4401 NFFPA D03	DIN 24340 A10 ISO 4401 NFFPA D05
Mounting Position	Unrestricted	
Ambient Temperature Range	-20°C to +50°C (-4°F to +122°F)	
Hydraulic		
Maximum Operating Pressure	350 Bar (5075 PSI)	315 Bar (4568 PSI)
Pressure Range	175 Bar (2538 PSI), 350 Bar (5075 PSI)	
Pilot Ratio	4.5 : 1	
Leakage	On request	
Nominal Flow	60 LPM (15.9 GPM)	120 LPM (31.7 GPM)
Opening Pressure	0.3 LPM (0.1 GPM)	0.3 LPM (0.1 GPM)
Fluid	Hydraulic oil as per DIN 51524 ... 51525	
Fluid Temperature	-20°C to +80°C (-4°F to +176°F)	
Viscosity	Permitted	10 to 650 cSt / mm ² /s (46 to 3013 SSU)
	Recommended	30 cSt / mm ² /s (139 SSU)
Filtration	ISO Class 4406 (1999) 18/16/13 (acc. NAS 1638: 7)	

B

ZNS01

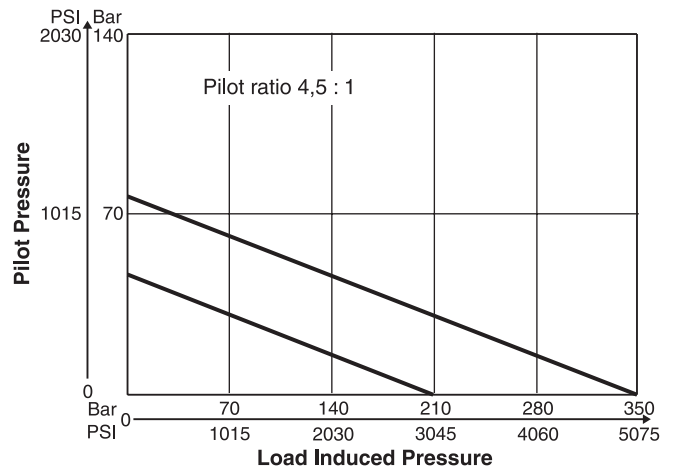
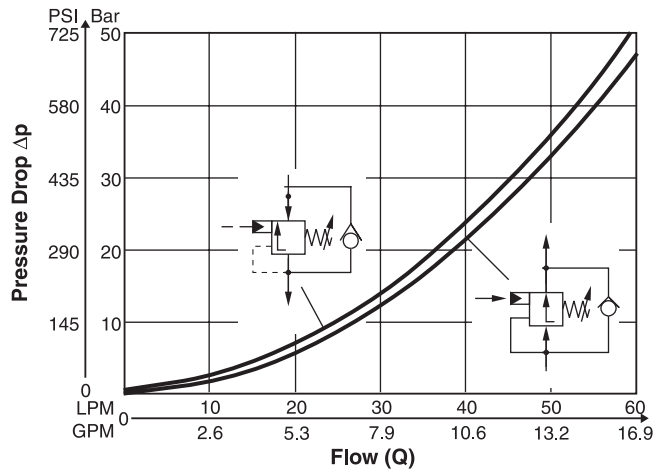

B

ZNS02

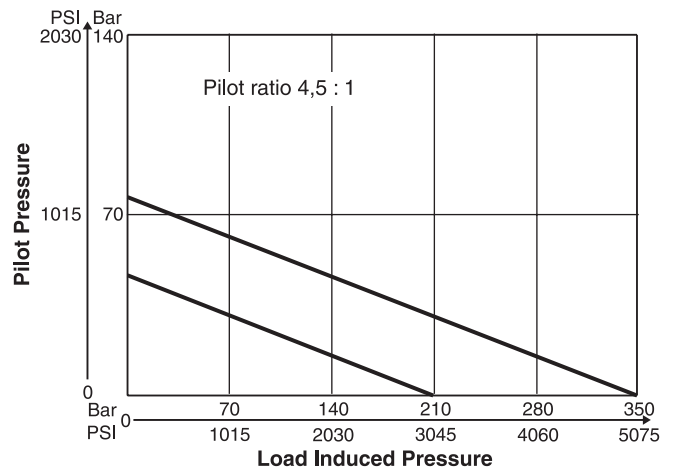
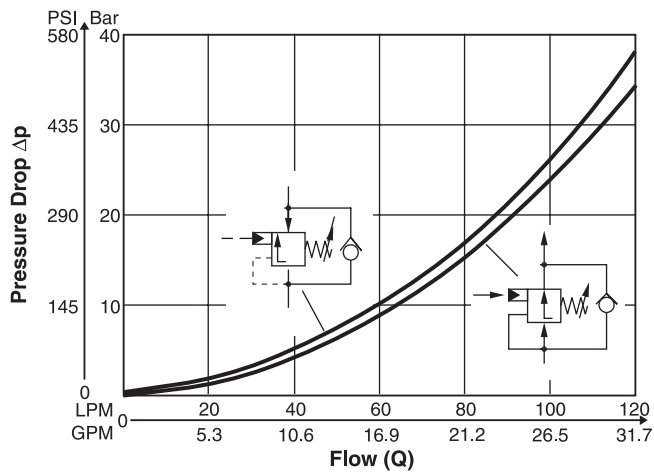

All characteristic curves measured with HLP46 at 50°C (122°F).

ZNS01 – Inch equivalents for millimeter dimensions are shown in (**)

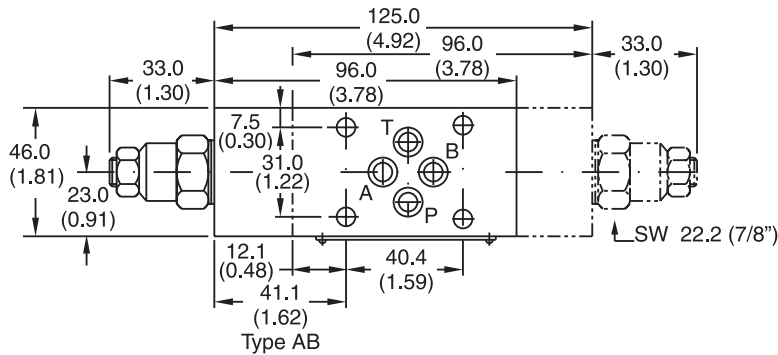
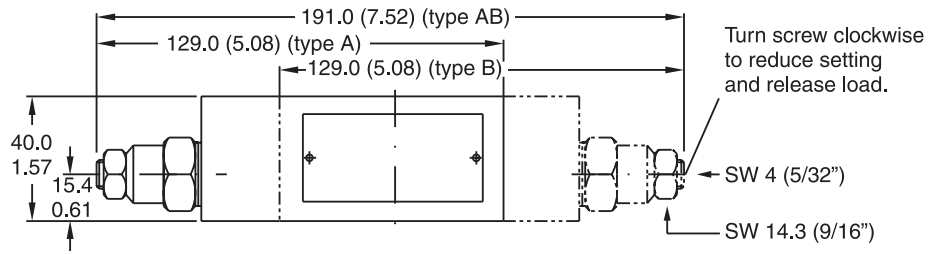

Seal Kit	
Seal	Order Code
1	098-91153-0
5	098-91154-0
Complete Cartridge	
Seal	Order Code
1	517-01017-2
5	517-00448-8

ZNS02 – Inch equivalents for millimeter dimensions are shown in (**)

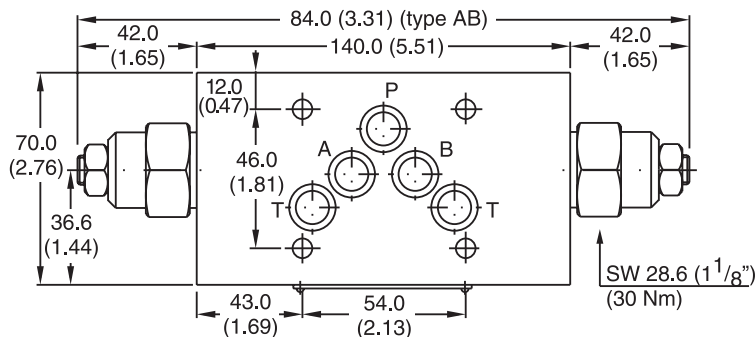
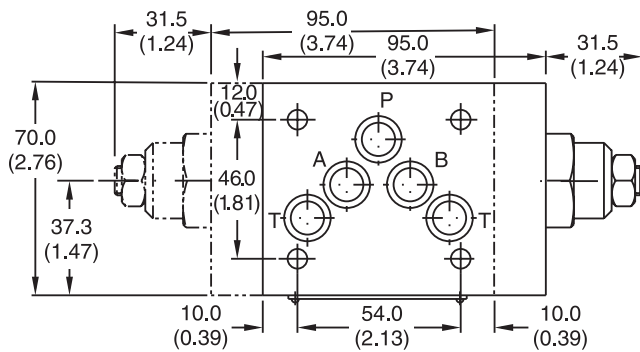
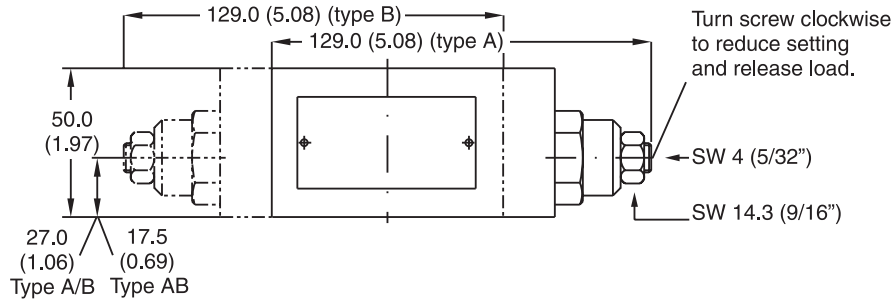

Seal Kit	
Seal	Order Code
1	098-91155-0
5	098-91183-0
Complete Cartridge	
Seal	Order Code
1	517-00449-8
5	517-00450-8

General Description

Series ZRD throttle check valves are designed for maximum flow rates.

The throttle check function can be located in port A or B as well as in A + B. Meter-in or meter-out functionality can be selected by model code.

A low flow / high resolution version in NFPA 03 / NG6 for sensitive shifting time adjustment of pilot operated directional control valves is available on request.

Features

- High flow capacity.
- Various functional arrangements.
- Sizes:
 - ZRD01 – NFPA D03 / NG6 / CETOP 3
 - ZRD02 – NFPA D05 / NG10 / CETOP 5

Ordering Information

ZRD
 Throttle Valve with Check

Meter Option

Size

S0
 Hexagon Screw with Lock Nut

D
 Design Series

Seal

Code	Description
AA	Meter-out Control in A
AZ	Meter-in Control in A
BA	Meter-out Control in B
BZ	Meter-in Control in B
ABA	Meter-out Control in A and B
ABZ	Meter-in Control in A and B

Code	Description
01	NFPA D03 / NG6
02	NFPA D05 / NG10

Code	Description
1	Nitrile
5	Fluorocarbon

Weight:	1 Cartridge	2 Cartridges
ZRD*01	1.2 kg (2.6 lbs)	1.3 kg (2.9 lbs)
ZRD*02	2.8 kg (6.2 lbs.)	2.9 kg (6.4 lbs.)

ZRD01

Meter-in control in A

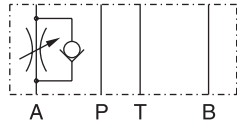

Series ZRDZA01S0D1

Meter-out control in B

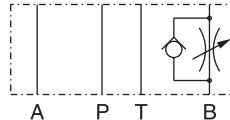

Series ZRDBA01S0D1

Meter-in control in B

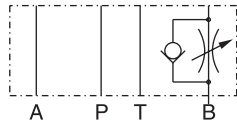

Series ZRDBZ01S0D1

Meter-in control in A and B

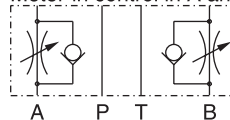

Series ZRDABZ01S0D1

Meter-out control in A

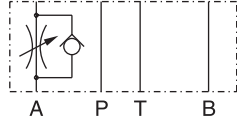

Series ZRDAA01S0D1

Meter-out control in A and B

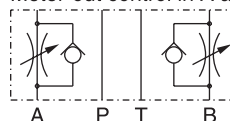

Series ZRDABA01S0D1

ZRD02
 (continued on next page)

Denison Sandwich.indd, dd



Ordering Information

ZRD02

Meter-in control in A

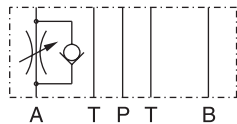

Series
 ZRDAZ02S0D1

Meter-out control in B

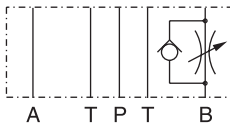

Series
 ZRDBA02S0D1

Meter-in control in B



Series
 ZRDBZ02S0D1

Meter-in control in A and B

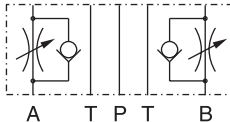

Series
 ZRDABZ02S0D1

Meter-out control in A

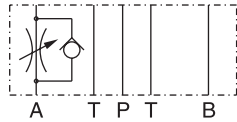

Series
 ZRDAA02S0D1

Meter-out control in A and B

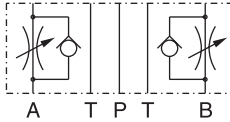

Series
 ZRDABA02S0D1

Specifications

General		
Size	NG6	NG10
Mounting	DIN 24340 A6 ISO 4401 NFPA D03 CETOP RP 121	DIN 24340 A10 ISO 4401 NFPA D05 CETOP RP 121 5
Mounting Position	Unrestricted	
Ambient Temperature	-20°C to +50°C (-4°F to +122°F)	
Hydraulic		
Max. Operating Pressure	350 Bar (5075 PSI)	
Nominal Flow	80 LPM (21.2 GPM)	160 LPM (42.3 GPM)
Leakage	—	—
Cracking Pressure	—	—
Fluid	Hydraulic oil as per DIN 51524 ... 51525	
Fluid Temperature	-20°C to +80°C (-4°F to +176°F)	
Viscosity	10 to 650 cSt / mm ² /s (46 to 3013 SSU)	
Permitted Recommended	30 cSt / mm ² /s (139 SSU)	
Filtration	ISO 4406 (1999) 18/16/13 (acc. NAS 1638: 7)	

p/Q Performance Curves

ZRD01

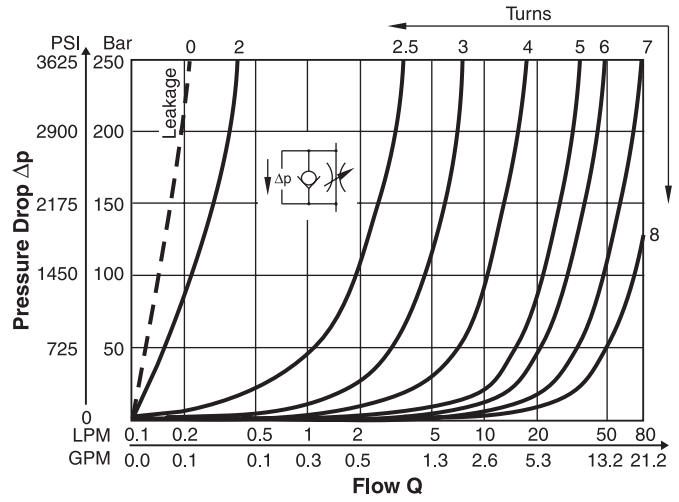
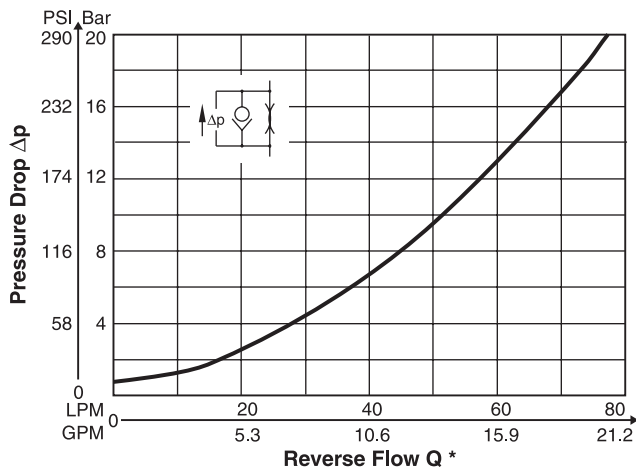

B

ZRD02

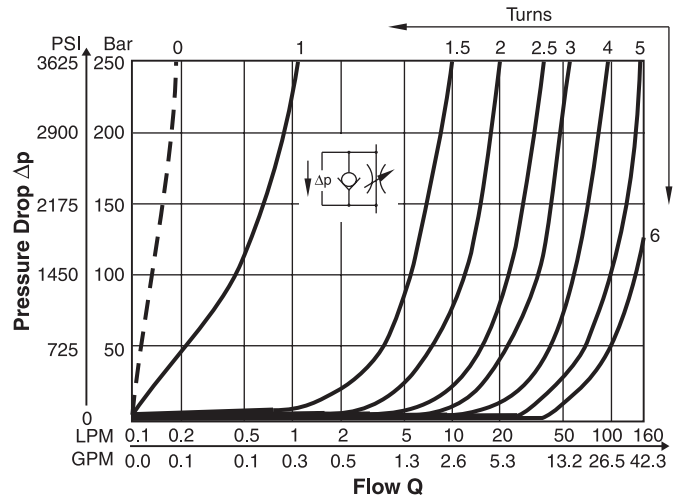
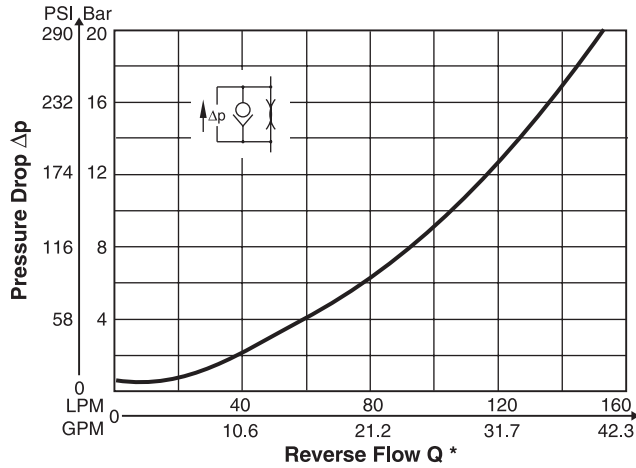

* Throttle closed

Fluid Viscosity 30 cSt @ 50°C (122°F)

ZRD01

Inch equivalents for millimeter dimensions are shown in (**)



B

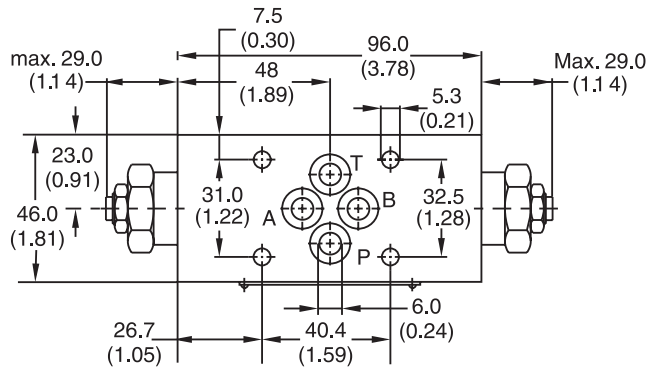

Seal Kit	
Seal	Order Code
1	098-91096-0
5	098-91097-0
Complete Cartridge	
Order Code	
098-91119-0	
O-ring Plate	
Order Code	
S26-27553-0	

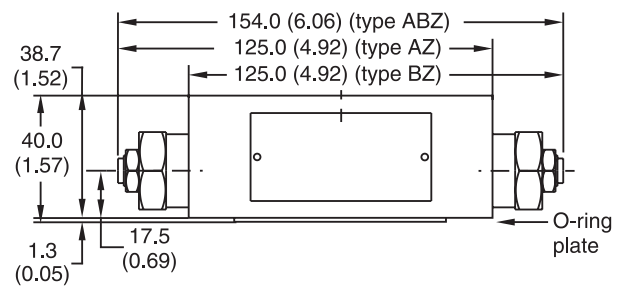
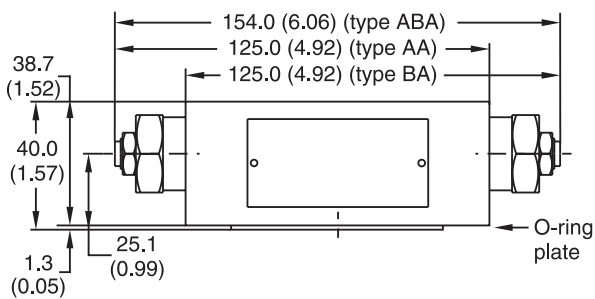

ZRD02

Inch equivalents for millimeter dimensions are shown in (**)

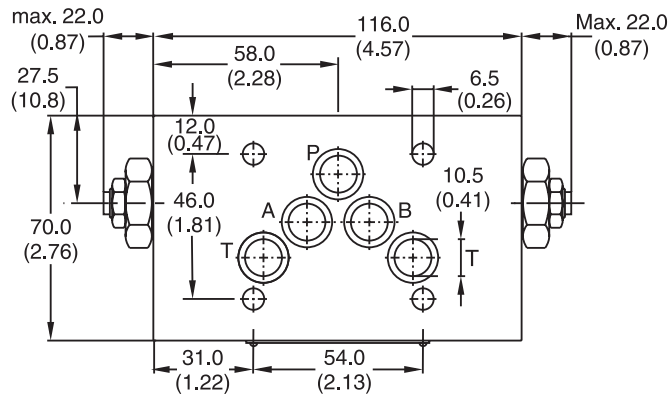

Seal Kit	
Seal	Order Code
1	098-91098-0
5	098-91099-0
Complete Cartridge	
Order Code	
098-91120-0	
O-ring Plate	
Order Code	
S16-85742-0	

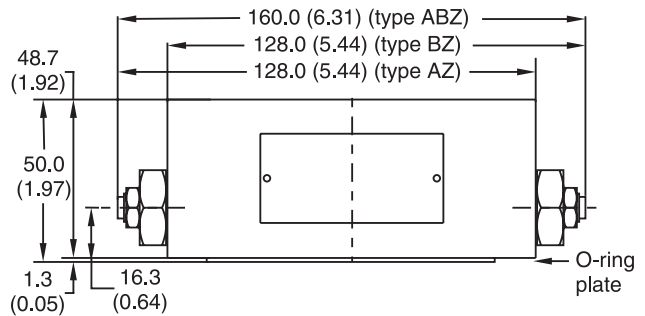
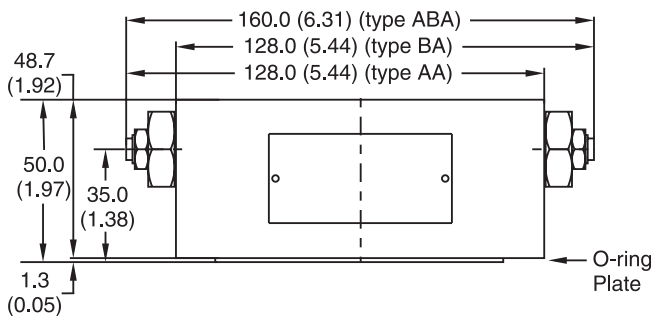

General Description.

Series ZRE pilot operated check valves are designed for maximum flow rates and long life time.

The valves are typically used in combination with spool type directional control valves to ensure leak free positioning of the actuator.

The inlet flow is free while the outlet flow is blocked. Pressure in the inlet line opens the check valve and allows free outlet flow.

Features

- High life time.
- Check function in A, B or A + B.
- Sizes:
 - ZRE01 – NFPA D03 / NG6 / CETOP 3
 - ZRE02 – NFPA D05 / NG10 / CETOP 5

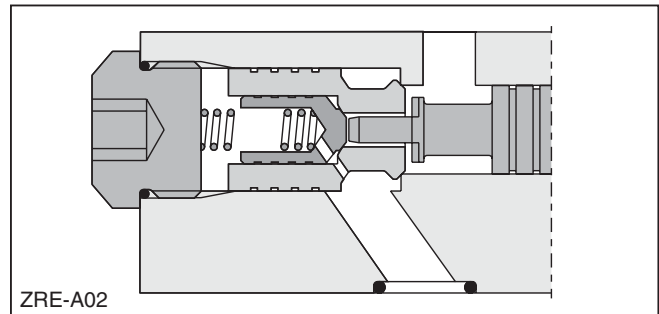
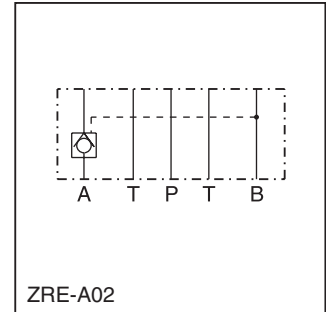

B

Ordering Information



Code	Description
A	Blocked in A
B	Blocked in B
AB	Blocked in A and B

Code	Description
01	NFPA D03 / NG6
02	NFPA D05 / NG10

Code	Description
D	Size 01
E	Size 02

Code	Description
1	Nitrile
5	Fluorocarbon

Weight:
 ZRE*01 1.2 kg (2.6 lbs)
 ZRE*02 3.1 kg (6.8 lbs.)

ZRE01

blocked in A and B

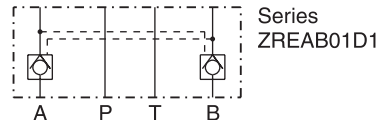

blocked in A

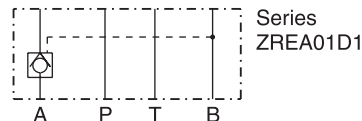

blocked in B

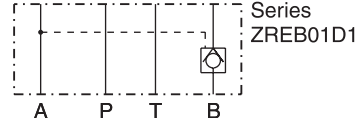

ZRE02

blocked in A and B

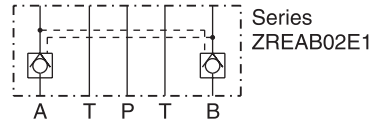

blocked in A

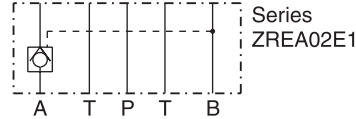

blocked in B

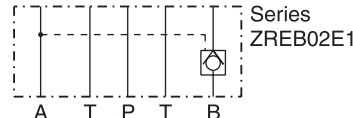

Specifications

General		
Size	NG6	NG10
Mounting Interface	DIN 24340 A6 ISO 4401 NFPA D03 CETOP RP 121	DIN 24340 A10 ISO 4401 NFPA D05 CETOP RP 121 5
Mounting Position	Unrestricted	
Ambient Temperature	-20°C to +50°C (-4°F to +122°F)	
Hydraulic		
Max. Operating Pressure	350 Bar (5075 PSI)	
Nominal Flow	60 LPM (15.9 GPM)	120 LPM (31.7 GPM)
Opening Ratio (Pilot Cone/Main Cone)	1:6	1:6
Cracking Pressure	1.2 Bar (17.4 PSI)	2.0 Bar (29.0 PSI)
Fluid	Hydraulic oil in accordance with DIN 51524 ... 51525	
Fluid Temperature	-20°C to +80°C (-4°F to +176°F)	
Viscosity	10 to 650 cSt / mm ² /s (46 to 3013 SSU)	
Permitted	30 cSt / mm ² /s (139 SSU)	
Recommended		
Filtration	ISO 4406 (1999) 18/16/13 (acc. NAS 1638: 7)	

Performance Curves

p/Q

ZRE01

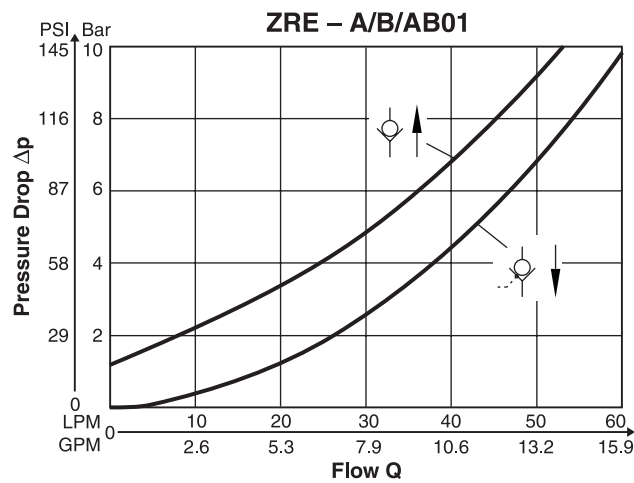

ZRE02

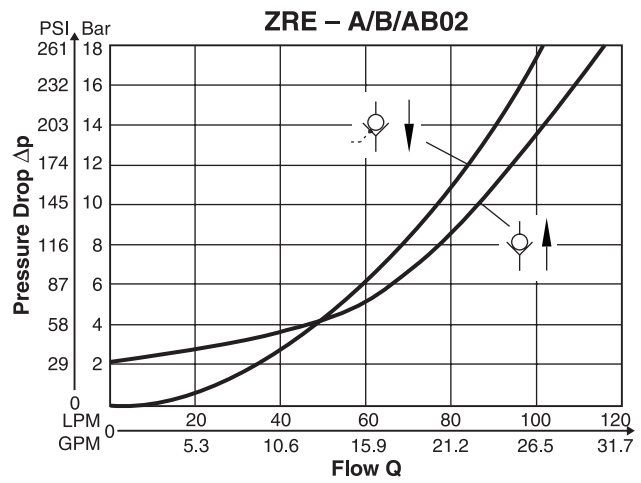

Fluid Viscosity 30 cSt at 50°C (122°F).

ZRE01

Inch equivalents for millimeter dimensions are shown in (**)

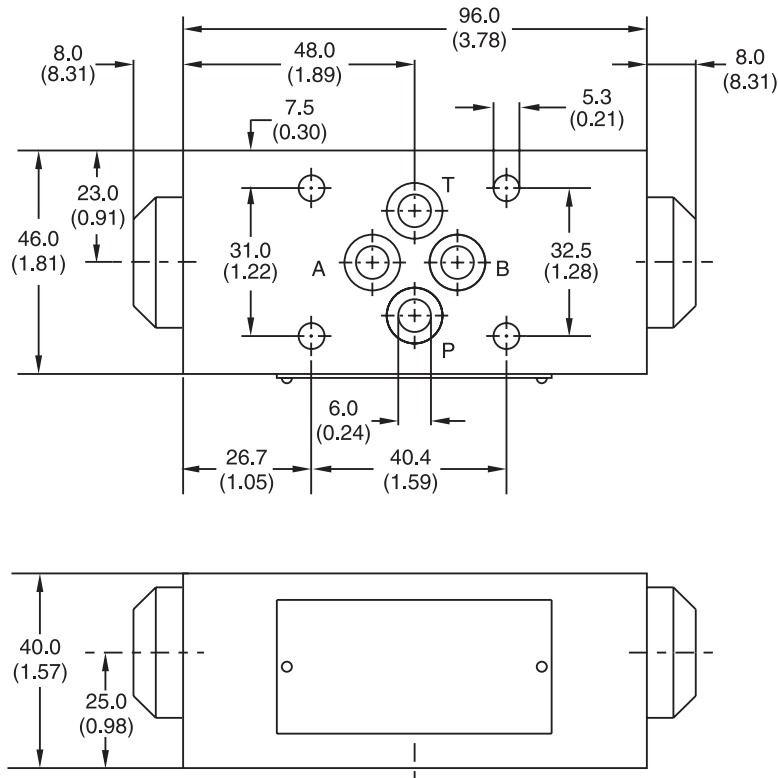

Seal Kit	
Seal	Order Code
1	098-91088-0
5	098-91089-0

B

ZRE02

Inch equivalents for millimeter dimensions are shown in (**)

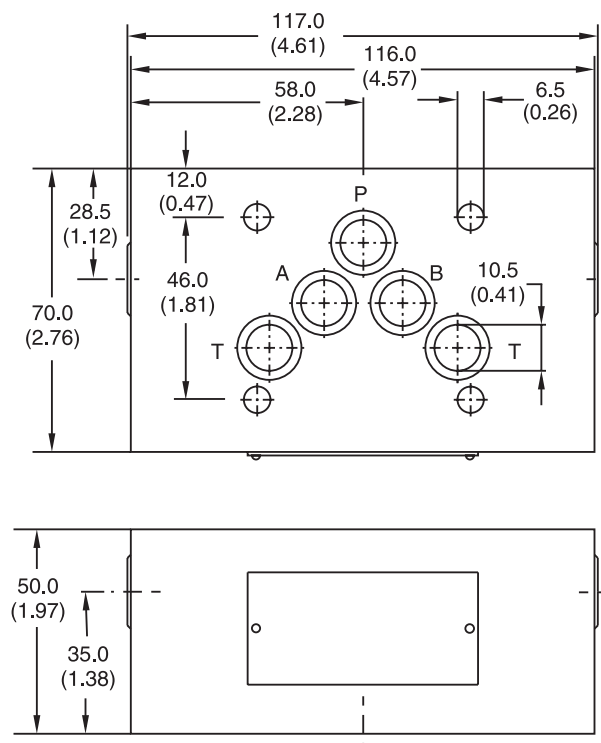

Seal Kit	
Seal	Order Code
1	098-91090-0
5	098-91091-0



General Description

Series ZRV direct operated check valves have a cartridge type insert to provide zero leakage and high life time.

The check function can be located in the P-port or in the T-port.

B

Features

- Leakage-free seat.
- High life time.
- Cracking pressure 0.5 Bar (7.25 PSI).
- Sizes:
 - ZRV01 – NFPA D03 / NG6 / CETOP 3
 - ZRV02 – NFPA D05 / NG10 / CETOP 5



ZRV-P02

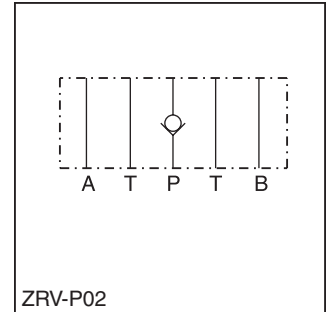

ZRV-P02

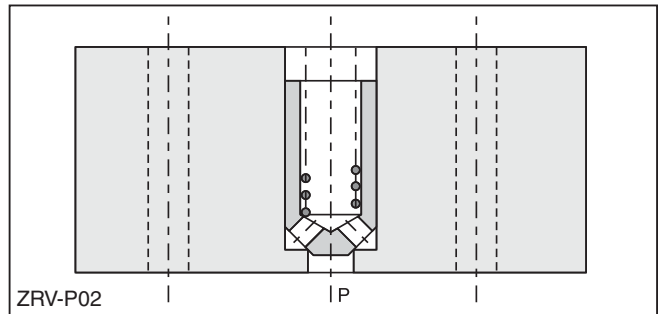

ZRV-P02

Ordering Information

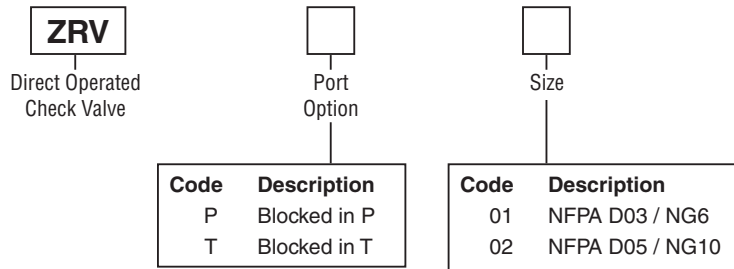

Weight:
 ZRV*01 0.7 kg (1.5 lbs)
 ZRV*02 2.0 kg (4.4 lbs.)

ZRV01

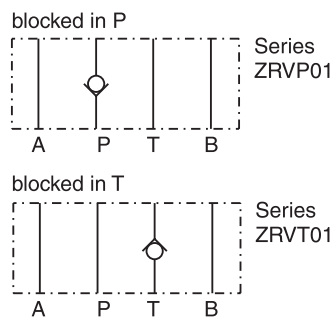

ZRV02

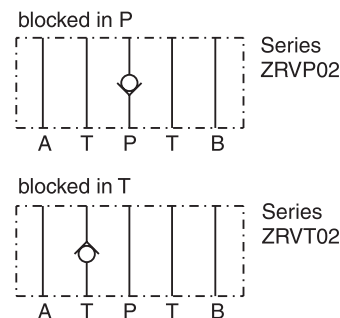

Specifications

General		
Size	NG6	NG10
Mounting Interface	DIN 24340 A6 ISO 4401 NFFPA D03 CETOP RP 121	DIN 24340 A10 ISO 4401 NFFPA D05 CETOP RP 121 5
Mounting Position	Unrestricted	
Ambient Temperature	-20°C to +50°C (-4°F to +122°F)	
Hydraulic		
Max. Operating Pressure	350 Bar (5075 PSI)	
Nominal Flow	40 LPM (10.6 GPM)	100 LPM (26.5 GPM)
Cracking Pressure	0.5 Bar (7.25 PSI)	0.5 Bar (7.25 PSI)
Fluid	Hydraulic oil as per DIN 51524 ... 51525	
Fluid Temperature	-20°C to +80°C (-4°F to +176°F)	
Viscosity	10 to 650 cSt / mm ² /s (46 to 3013 SSU)	
Permitted Recommended	30 cSt / mm ² /s (139 SSU)	
Filtration	ISO 4406 (1999) 18/16/13 (acc. NAS 1638: 7)	

B

p/Q Performance Curves

ZRV P/T01

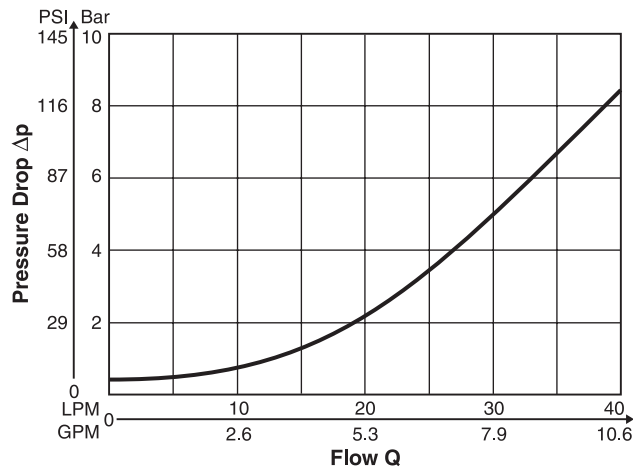

Fluid Viscosity 30 cSt at 50°C (122°F)

ZRV P/T02

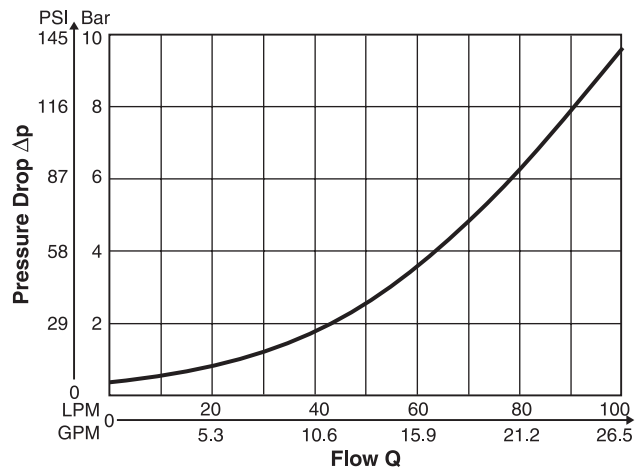

Fluid Viscosity 30 cSt at 50°C (122°F)

ZRV01 – Inch equivalents for millimeter dimensions are shown in (**)

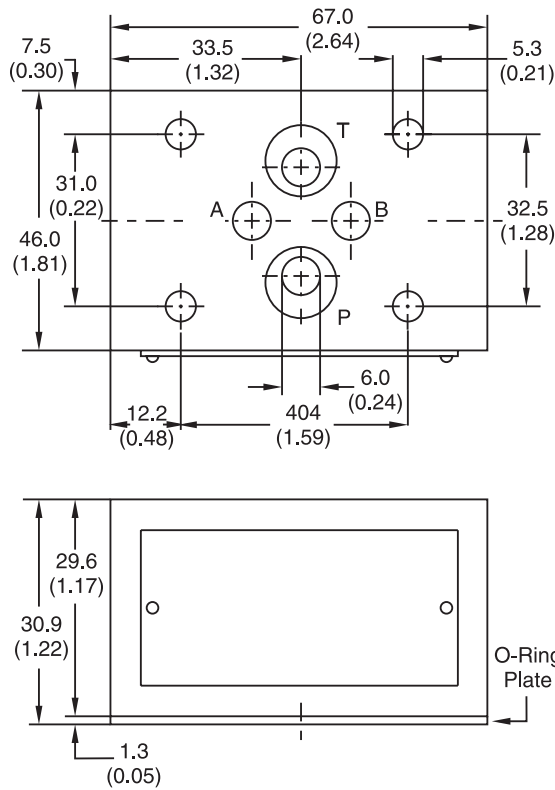

ZRV02 – Inch equivalents for millimeter dimensions are shown in (**)

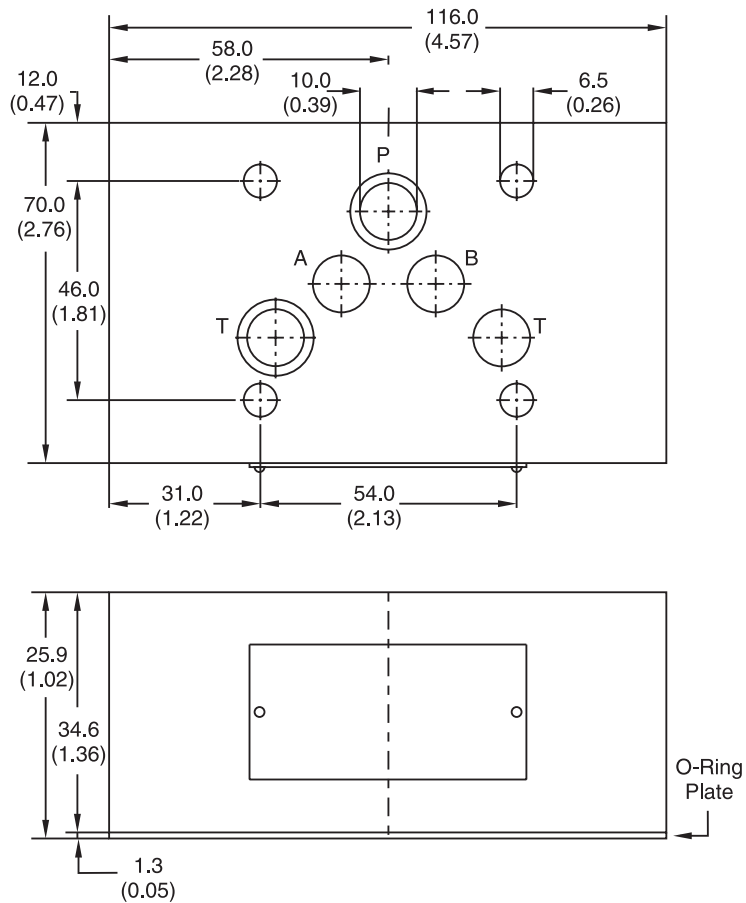

CAUTION:
Sandwich Installation

Prior to installation of Sandwich valves, please review flow paths. Due to the reversibility of the DO3 size, incorrect installation will alter the hydraulic circuit. Care must be taken during installation to insure that the Sandwich is installed in compliance with the hydraulic schematic. Please consult with your Parker representative with any questions that may arise.

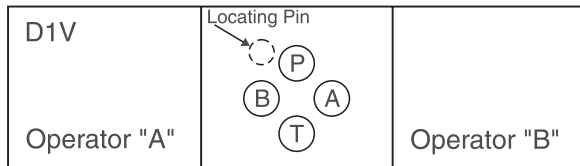

Pressure Ratings

Unless otherwise specified, all Parker Sandwich valves have continuous duty pressure rating as shown in this catalog.

Special Requirements

Consult your Parker representative for factory recommendations on such situations as:

- Installations that will operate at pressures higher than published catalog ratings.
- Use of hydraulic fluids which do not meet our recommended specifications.
- Operations where fluid temperature will exceed 121°C (250°F).

Recommended Mounting Surface

Surface must be flat within .0004 inch T.I.R. and smooth with 32 micro-inch.

System Cleanliness

Any hydraulic system that includes Parker valves should be carefully protected against dirt and fluid contamination. Life of the valves, as well as of all other components, will be greatly lengthened. Operation will be smoother and more precise. Maintenance and repairs will be reduced. Lost production because of low pressure and flow will be minimized. Fluid contamination should be maintained to less than 500 particles larger than 10 micrometers per milliliter of fluid (SAE class 4 or better/ISO Code 16/13).

Hydraulic Fluids

Parker recommends using top-quality hydraulic fluids having a viscosity range of 32 to 54 cSt (150 to 250 SSU) at 38°C (100°F). The absolute viscosity range should be 16 to 220 cSt (80 to 1000 SSU). Fluids should have highest anti-wear characteristics and be treated to avoid rust and oxidation.

Seals

When used with water-glycol, water/oil emulsions, and high-grade petroleum base hydraulic fluids, Parker standard nitrile seals are suitable.

When using phosphate ester fluids or their blends, specify Parker optional seals made of fluorocarbon. Synthetic fire-resistant fluids require special seal materials which your Parker representative can recommend.

Torque Specifications

The recommended torque valves are for the bolts which mount the valve to the manifold or subplate are as follows:

Size	Torque Valve
D03	5.7 N.m. (50 in.-lbs.)
D05	16.3 N.m. (12 ft.-lbs.)
D07	63.0 N.m. (46.5 ft.-lbs.)
D08	108.5 N.m. (80 ft.-lbs.)



Mounting Pattern – NFPA D03, CETOP 3 & NG6

Inch equivalents for millimeter dimensions are shown in (**)

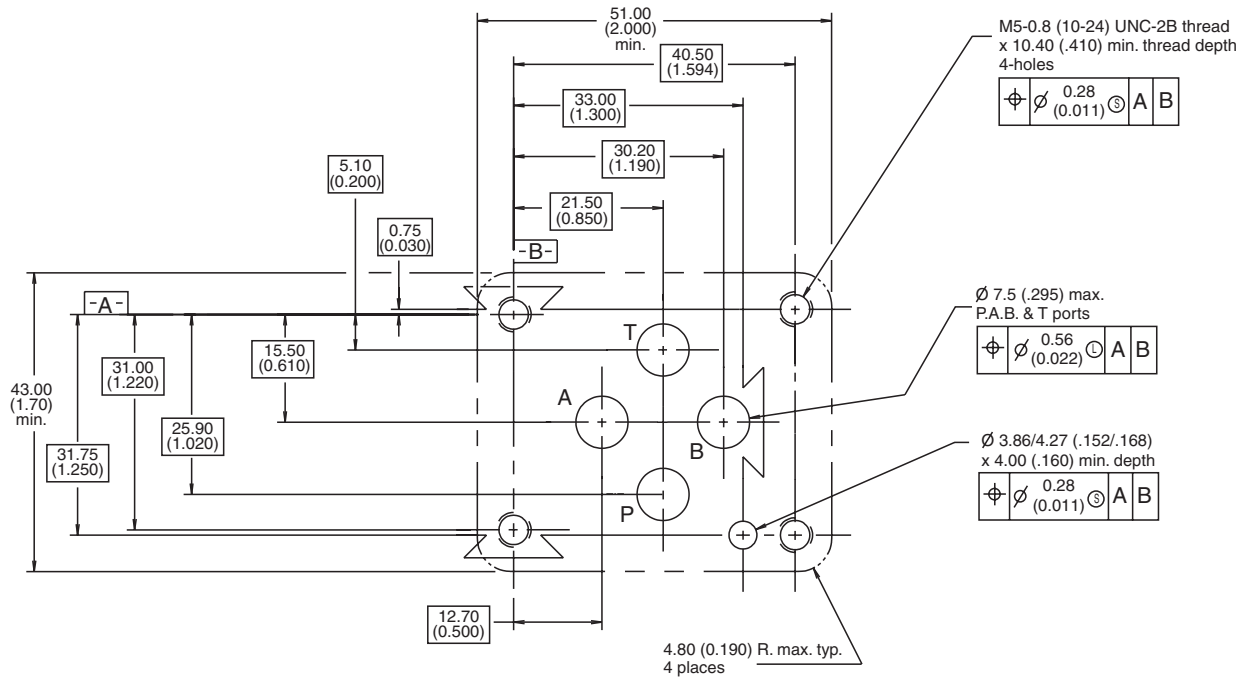

Mounting Pattern – NFPA D05, CETOP 5 & NG10

Inch equivalents for millimeter dimensions are shown in (**)

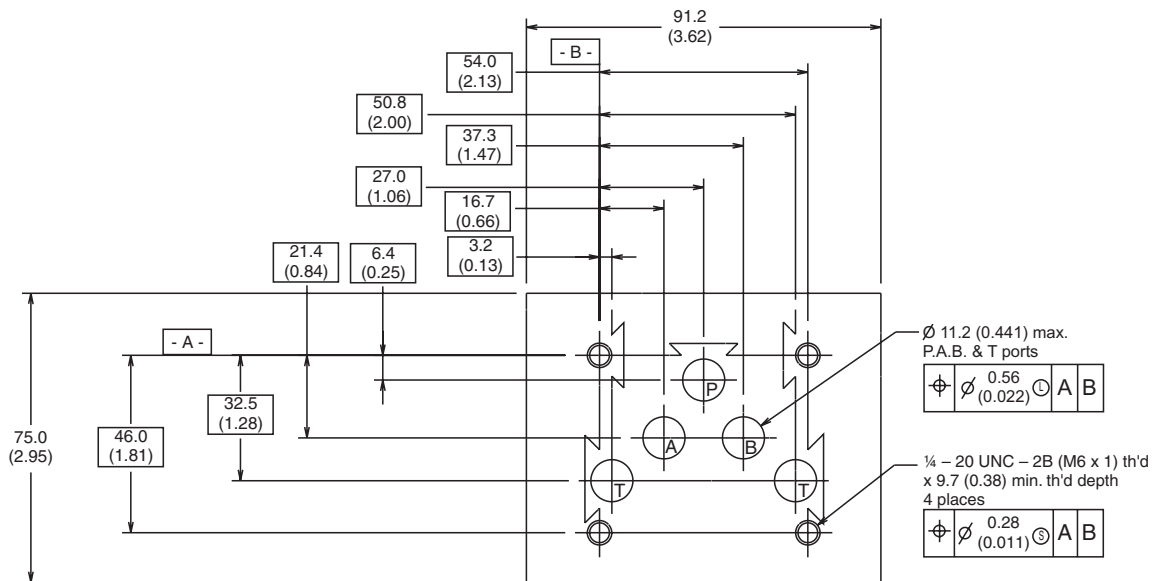

Mounting Pattern – NFPA D07, CETOP 7 & NG16

Inch equivalents for millimeter dimensions are shown in (**)

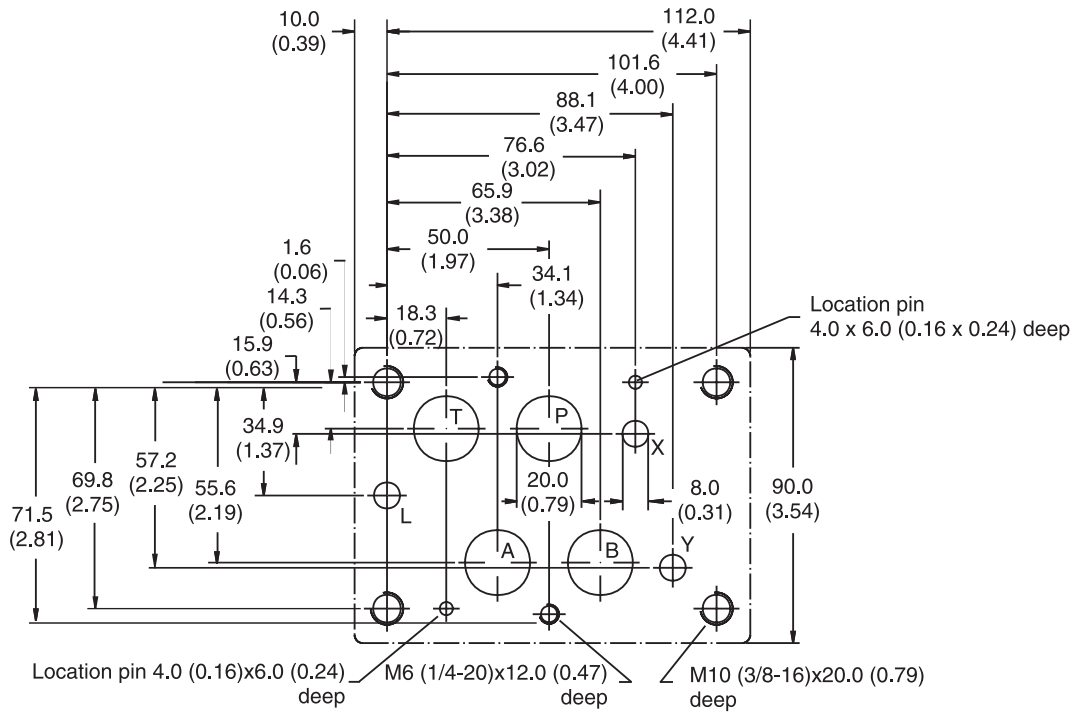

Mounting Pattern – NFPA D08, CETOP 8 & NG25

Inch equivalents for millimeter dimensions are shown in (**)

