

C

PRESSURE CONTROLS





SOLTECH

PRESSURE CONTROLS

REMOTE CONTROL RELIEF VALVES

[DG-01, DT-01]

※SPECIFICATION

MODEL	SIZE	MAX. PRES. MPa(Psi)	MAX. FLOW ℓ/min(GPM)	WEIGHT (Kg)
DT, DG	01	25 (3630)	16(4.2)	1.5

※ACCESSORIES

MODEL	SOCKET HEAD SCREW CAP			O RING	
	European Design. Std.	N. America Design Std.			
DG-01	M5 × 45 Lg.	No.10-24UNC × 1-3/4 Lg.	4 Pcs	P9	2 Pcs

※GRAPHIC SYMBOL

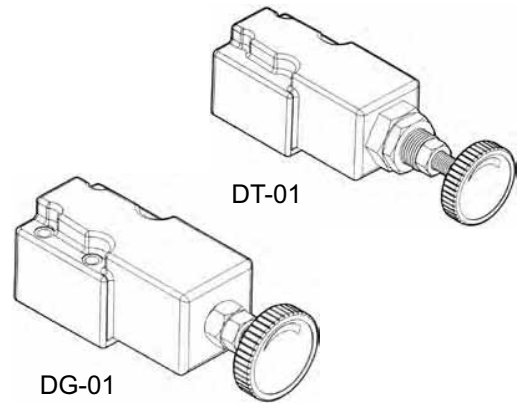
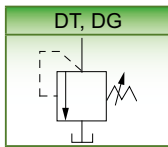

※MODEL NUMBER DESIGNATION

D	G	01	B	(90)
SERIES NO.	TYPE OF CONNECTION G: SUB-PLATE TYPE T: THREADED TYPE	VALVE SIZE 01: 1/4"	PRESSURE ADJ. RANGE MPa(psi) B:0.7~7(101.5~1015) C:3.5~14(507.5~2030) H:7~25(1015~3630)	DESIGN No. OMIT: DIN 912 BOLTS 90: UNC BOLTS (NORTH AMERICA)

※PERFORMANCE CURVE

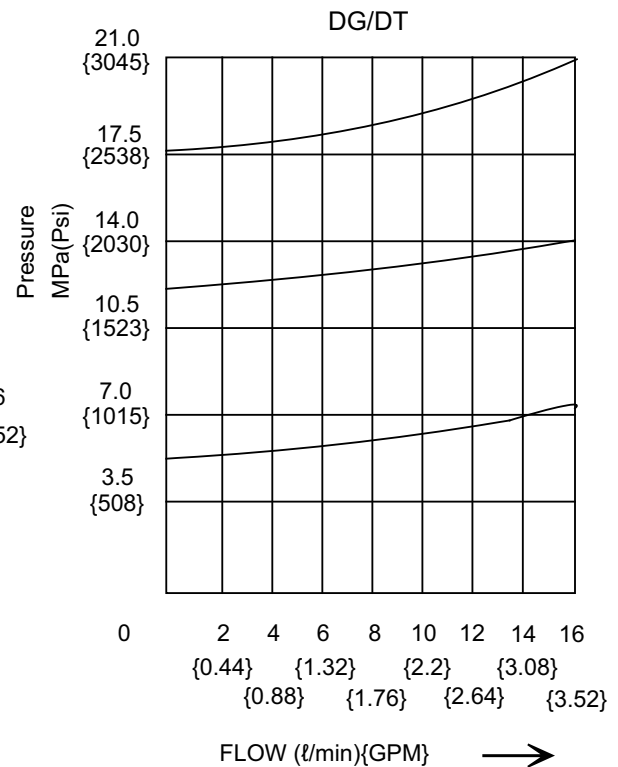
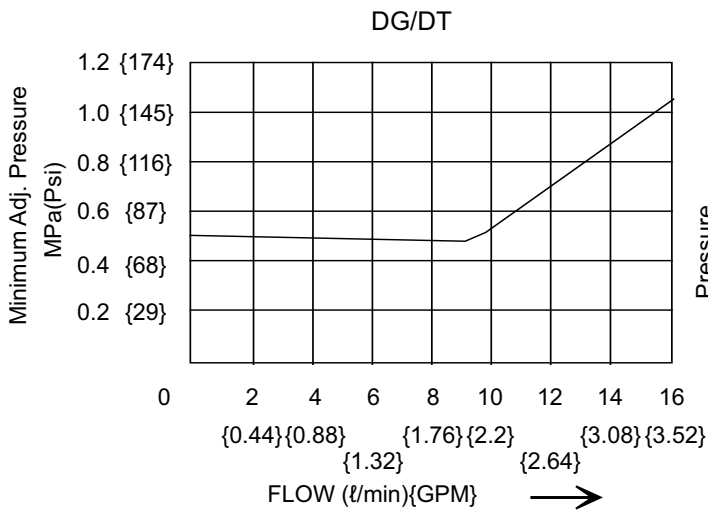



SOLTECH

PRESSURE CONTROLS

REMOTE CONTROL RELIEF VALVES

C

DIMENSIONS

DG-01

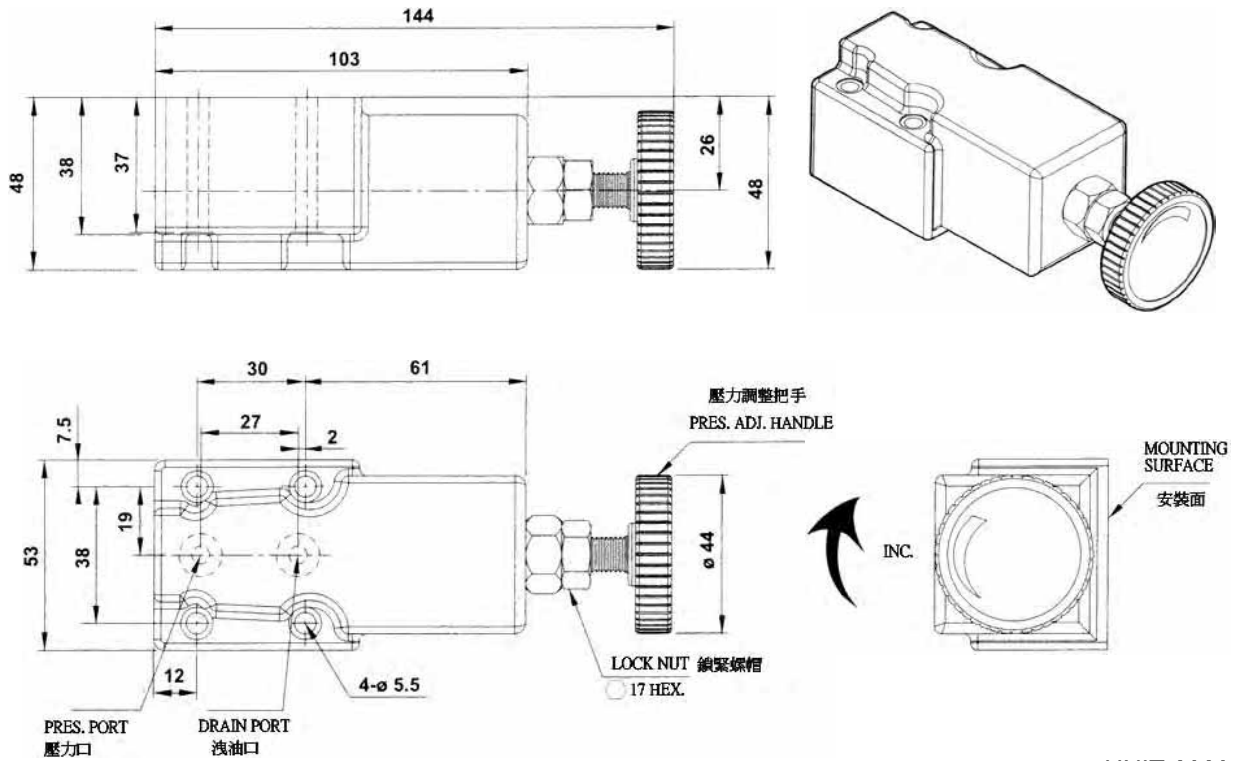

UNIT: M.M.

DIMENSIONS

DT-01

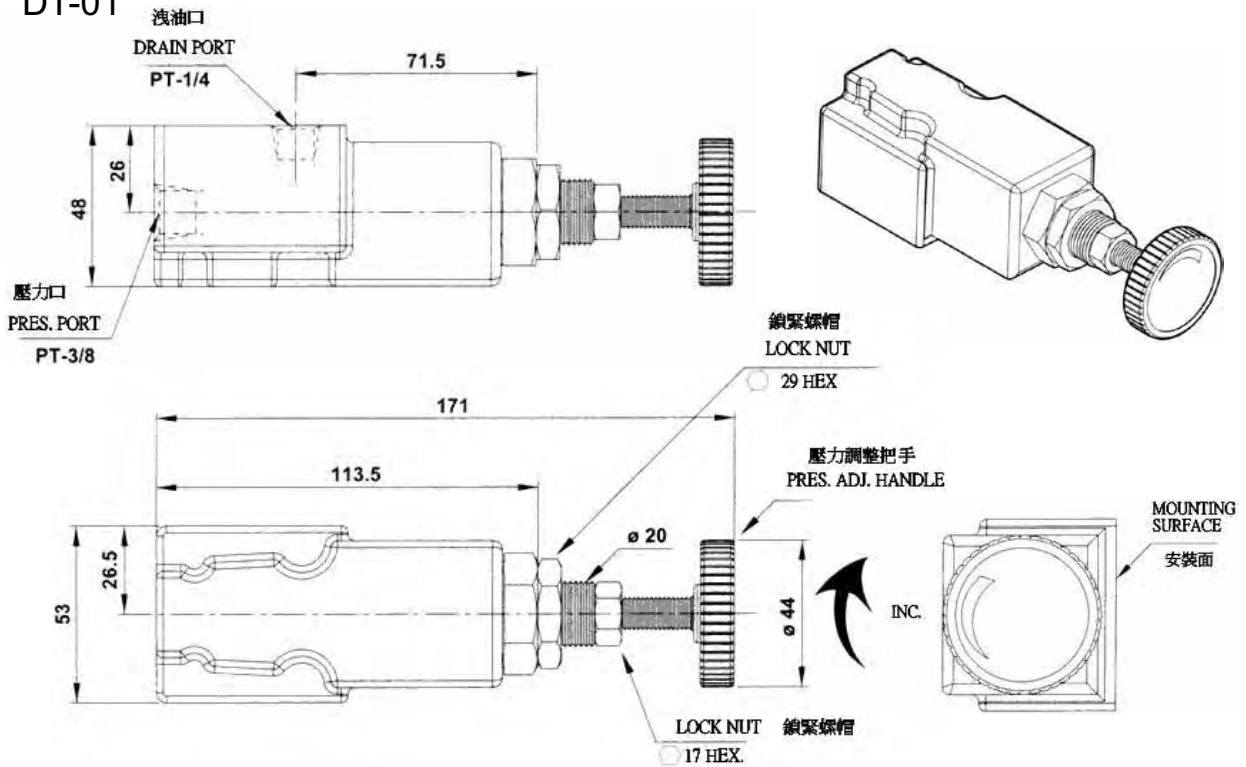

UNIT: M.M.



SOLTECH

PRESSURE CONTROLS

DIRECT TYPE RELIEF VALVES

[DG-02, DT-02]

※SPECIFICATION

MODEL	SIZE	MAX. PRES. MPa(Psi)	MAX. FLOW ℓ/min(GPM)	WEIGHT (Kg)
DT, DG	02	21(3050)	16(4.2)	1.5

※ACCESSORIES

MODEL	SOCKET HEAD SCREW CAP			O RING
	European Design. Std.	N. America Design Std.		
DG-01	M5 × 45 Lg.	No.10-24UNC × 1-3/4 Lg.	4 Pcs	P9 2 Pcs

※GRAPHIC SYMBOL

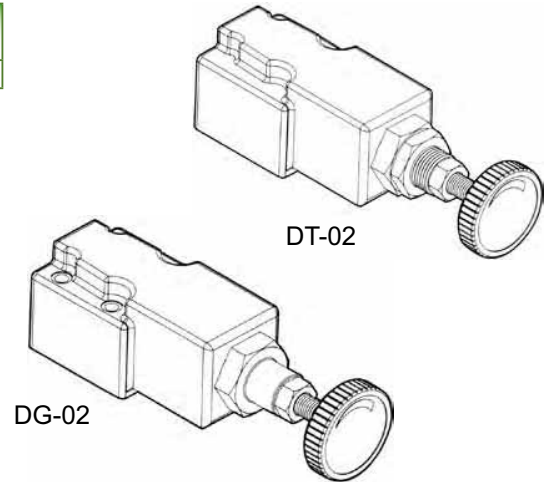
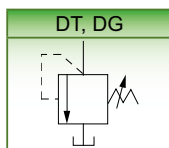

※MODEL NUMBER DESIGNATION

D	G	02	B	(90)
SERIES NO.	TYPE OF CONNECTION G: SUB-PLATE TYPE T: THREADED TYPE	VALVE SIZE 02: 1/4"	PRESSURE ADJ. RANGE MPa(psi) B:0.7~7(101.5~1015) C:3.5~14(507.5~2030) H:7~21(1015~3050)	DESIGN No. OMIT: DIN 912 BOLTS 90: UNC BOLTS (NORTH AMERICA)

※PERFORMANCE CURVE

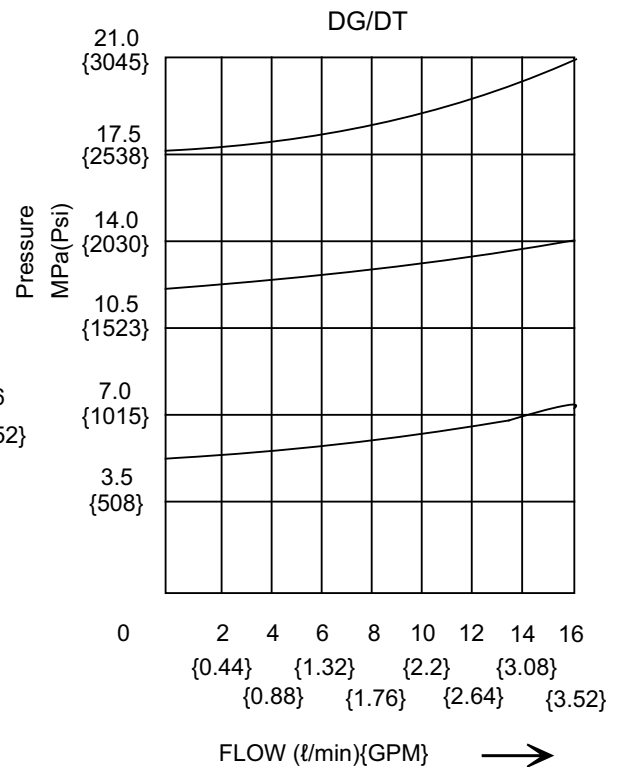
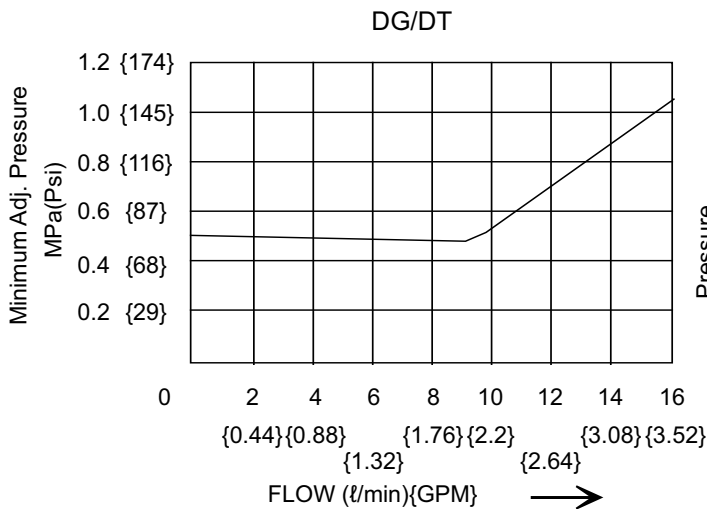



SOLTECH

PRESSURE CONTROLS

DIRECT TYPE RELIEF VALVES

DIMENSIONS

DG-02

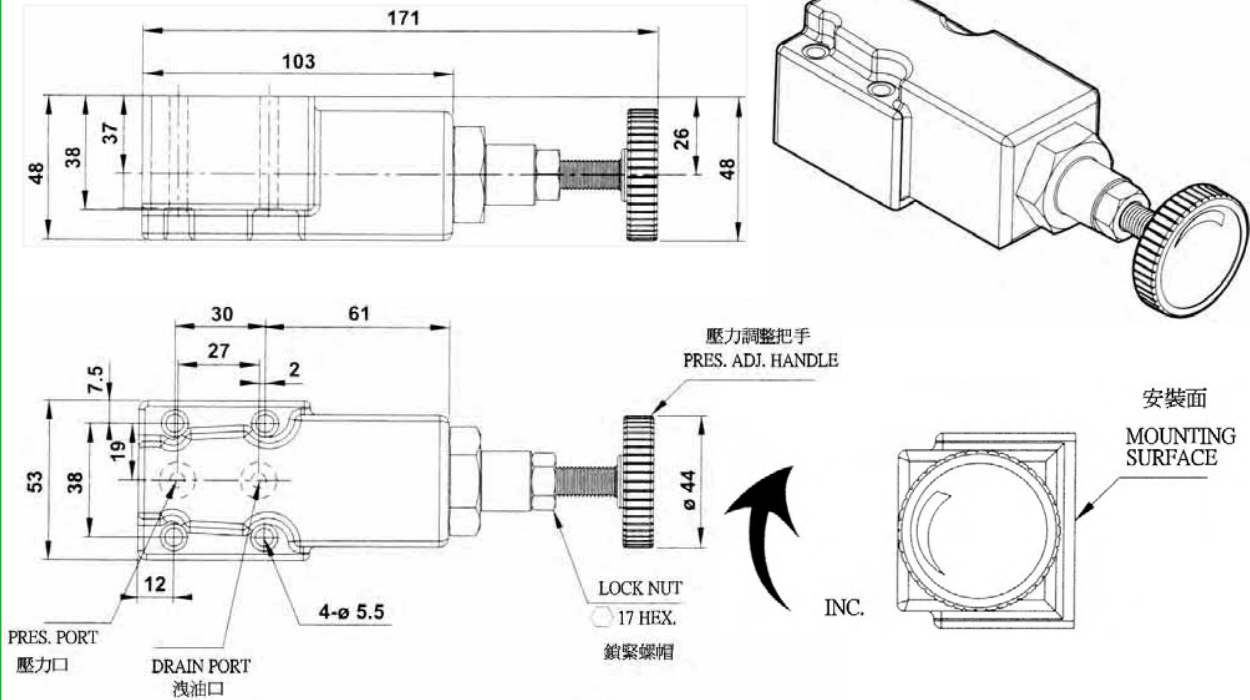

UNIT: M.M.

DIMENSIONS

DT-02

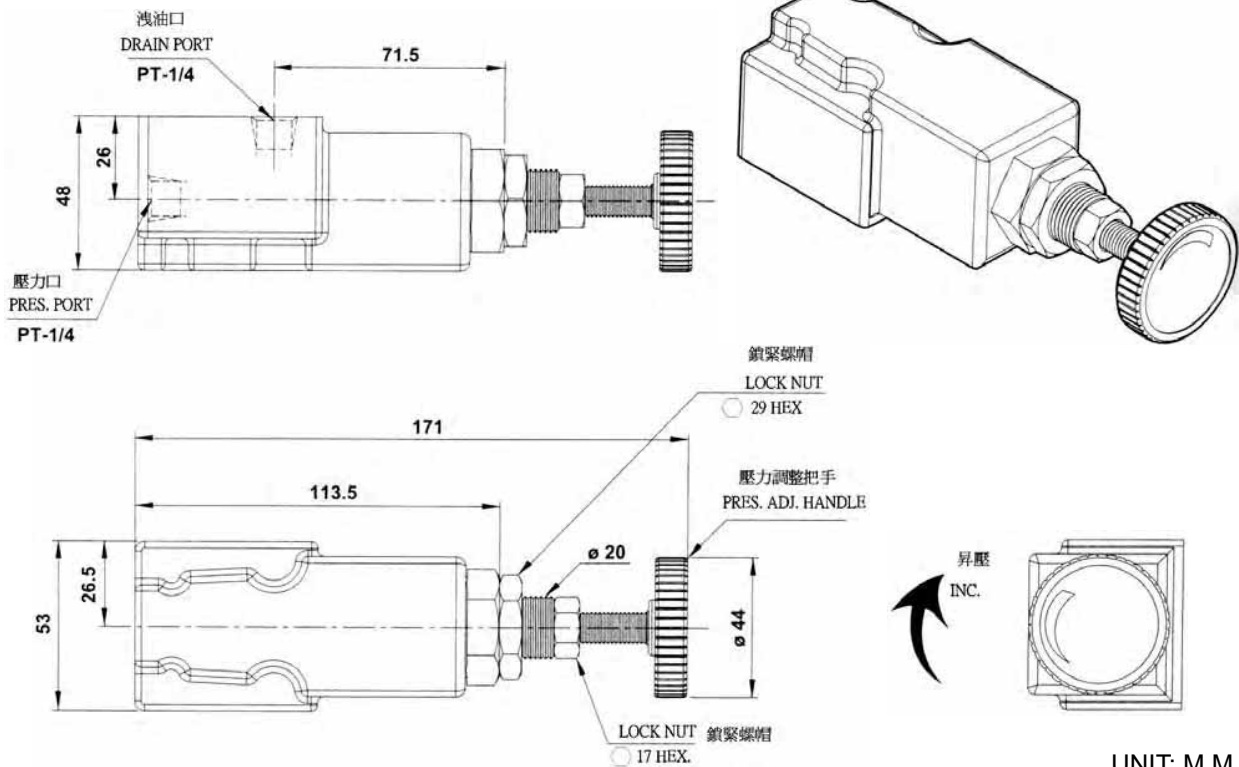

UNIT: M.M.

C



SOLTECH

PRESSURE CONTROLS

PILOT OPERATED RELIEF VALVES

[BG/BT-03,06,10]

※SPECIFICATION

MODEL	SIZE	MAX. PRES. MPa(Psi)	MAX. FLOW ℓ/min(GPM)	WEIGHT (Kg)	
				BT	BG
BG, BT	03	25 (3630)	100(26.4)	2.5	5
	06		200(52.8)	3.5	6.2
	10		400(105.6)	9	10

※GRAPHIC SYMBOL

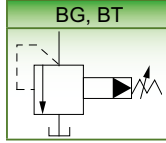

BG-03

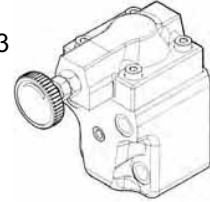

BT-04



※MODEL NUMBER DESIGNATION

B	G	03	B	(90)
SERIES NO.	CONNECTION TYPE G: SUB-PLATE TYPE T: THREADED TYPE	VALVE SIZE 03: 3/8", 6264-AR-06-2-A 04: 1/2" 06: 3/4", 6264-AS-08-2-A 10: 1(1/4)", 6264-AT-10-2-A	PRES. ADJ. RANGE MPa(psi) B:0.7~7(101.5~1015) C:3.5~14(507.5~2030) H:7~25(1015~3630)	DESIGN No. OMIT: DIN 912 BOLTS 90: UNC BOLTS (NORTH AMERICA)

※ACCESSORIES

MODEL	SOCKET HEAD SCREW CAP				O RING				
	European Design. Std.	N. America Design Std.			European Design. Std.	N. America Design Std.			
BG-03	M12×70L	1/2-13UNC × 2-3/4 Lg.	2	Pcs	M12×95L	1/2-13UNC × 3-3/4 Lg.	2	Pcs	P9 1 Pcs P20 2 Pcs
BG-06	M16×60L	5/8-11UNC × 2-1/4 Lg.	2	Pcs	M16×80L	5/8-11UNC × 3-1/4 Lg.	2	Pcs	P10A 1 Pcs P29 2 Pcs
BG-10	M20×70L	3/4-10UNC × 2-3/4 Lg.	2	Pcs	M20×90L	3/4-10UNC × 3-1/2 Lg.	2	Pcs	P10A 1 Pcs P36 2 Pcs

※PERFORMANCE CURVE

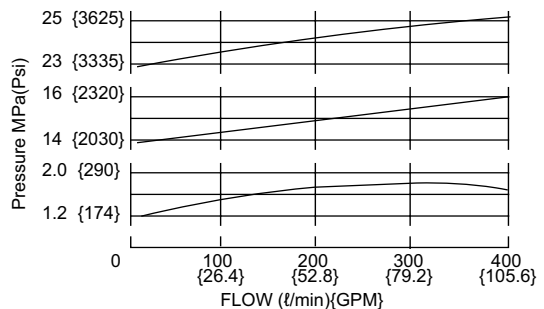
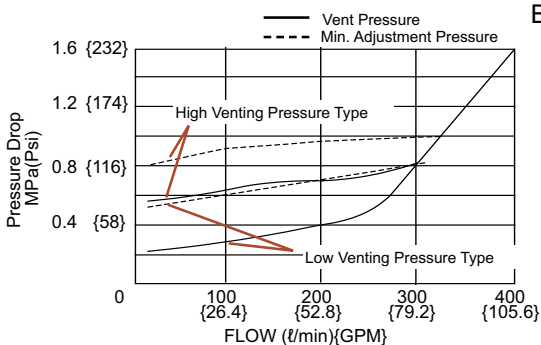
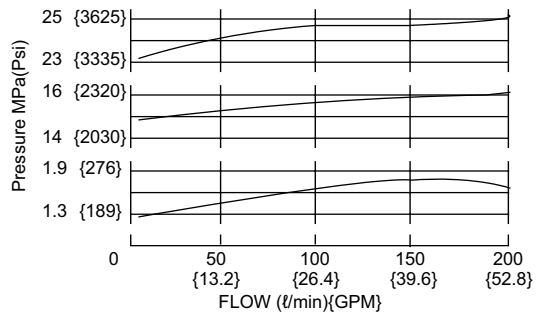
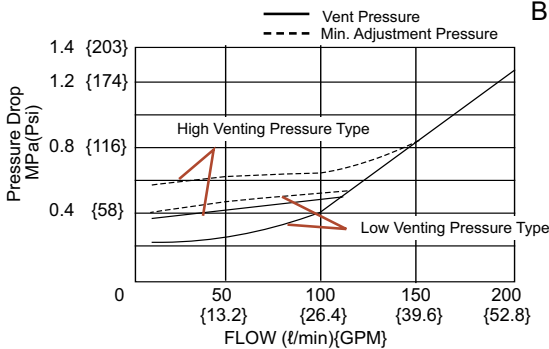
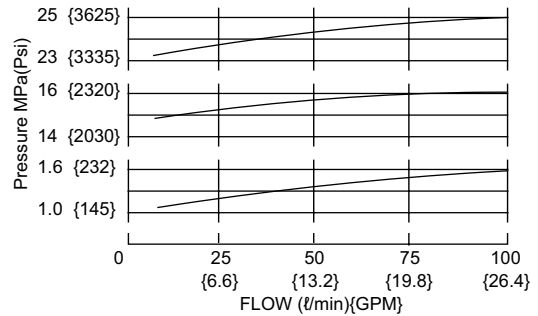
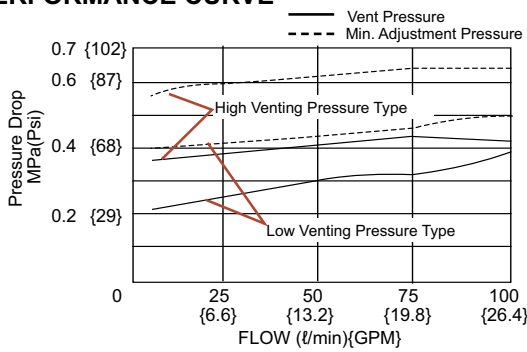



SOLTECH

PRESSURE CONTROLS

PILOT OPERATED RELIEF VALVES

C

DIMENSIONS

BG-SERIES

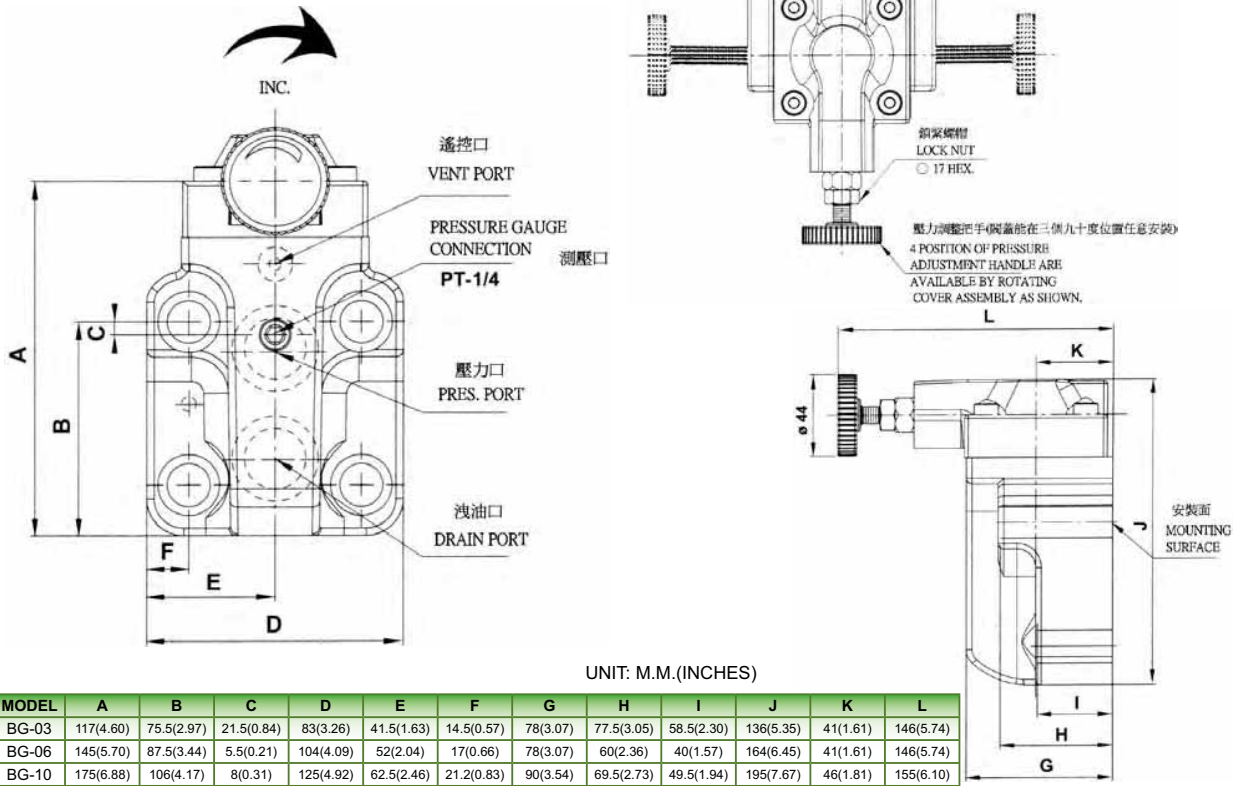

DIMENSIONS

BT-SERIES

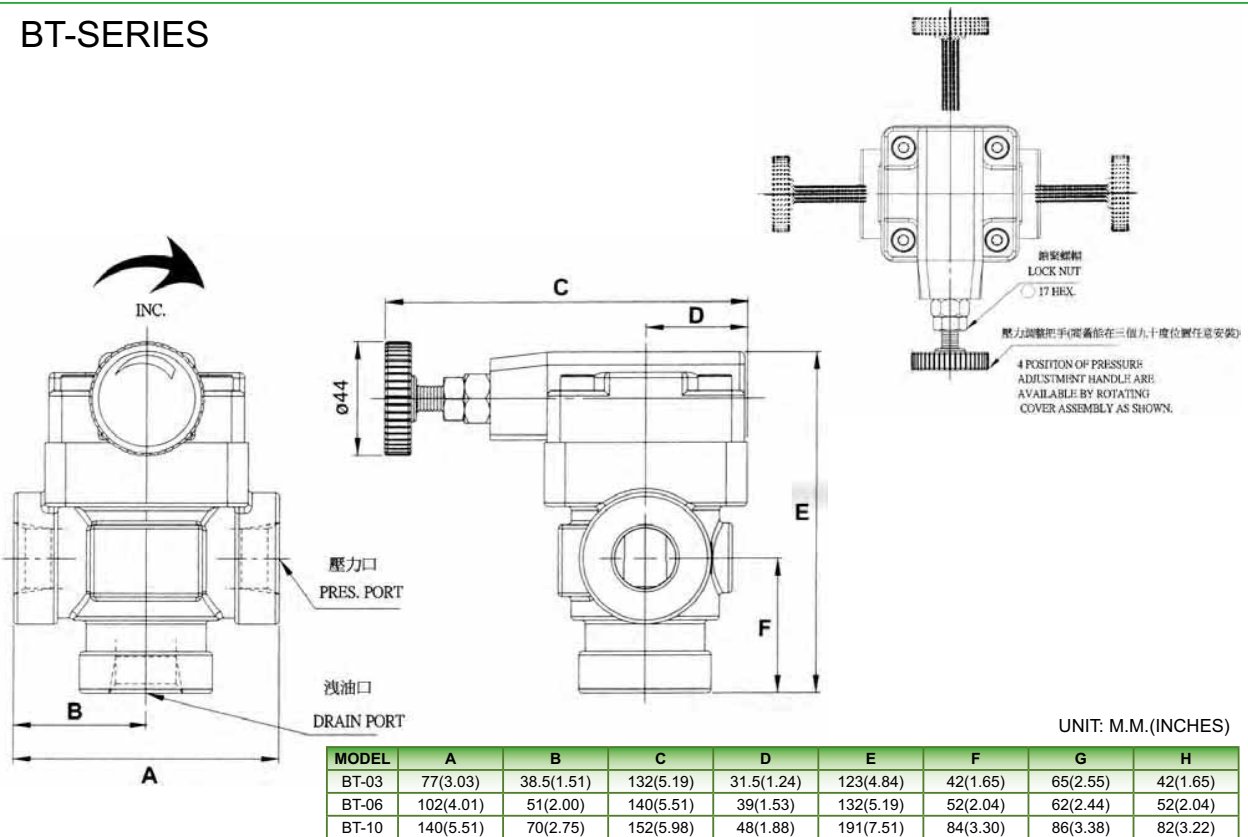



SOLTECH

PRESSURE CONTROLS

PILOT OPERATED RELIEF VALVES 【31.5MPa】

【HBG/HBT-03,06】

※SPECIFICATION

MODEL	SIZE	MAX. PRES. MPa(PSI)	MAX. FLOW ℓ/min(GPM)	
HBG	03	31.5 (4570)	100(26.4)	2.5
	06		200(52.8)	3
HBT	06		125(33)	5.2

HBG-03

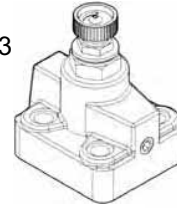

HBT-06

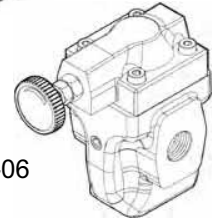

※MODEL NUMBER DESIGNATION

HB	G	03	B	(90)
SERIES NO. HB: 31.5MPa	CONNECTION TYPE G: SUB-PLATE TYPE T: THREADED TYPE	VALVE SIZE 03: 3/8" 06: 3/4"	PRESSURE ADJ. RANGE MPa(psi) B:0.7~7(101.5~1015) C:3.5~14(507.5~2030) H:10~31.5(1450~4570)	DESIGN No. OMIT: DIN 912 BOLTS 90: UNC BOLTS (NORTH AMERICA)

※ACCESSORIES

MODEL	SOCKET HEAD SCREW CAP		O RING				
	European Design. Std.	N. America Design Std.					
HBG-03	M12×45L	1/2-13UNC × 1-3/4 Lg.	4 Pcs	P9	1 Pcs	P20	2 Pcs
HBG-06	M16×45L	5/8-11UNC × 1-3/4 Lg.	4 Pcs	P9	1 Pcs	P29	2 Pcs

※GRAPHIC SYMBOL

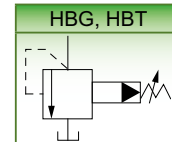

※PRODUCTS LIST

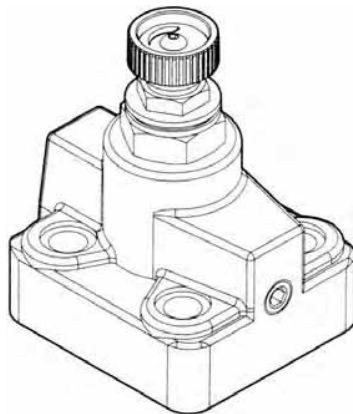

HBG-03

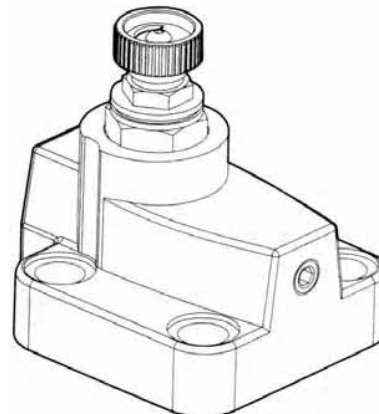

HBG-06

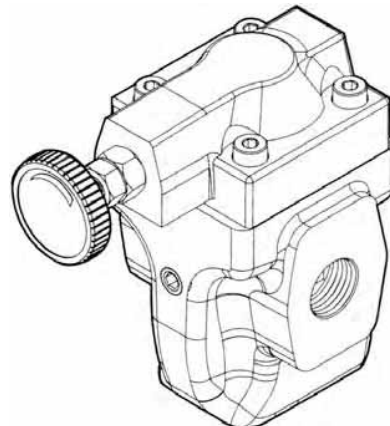

HBT-06



SOLTECH

PRESSURE CONTROLS

PILOT OPERATED RELIEF VALVES 【31.5MPa】

C

DIMENSIONS

HBG-SERIES

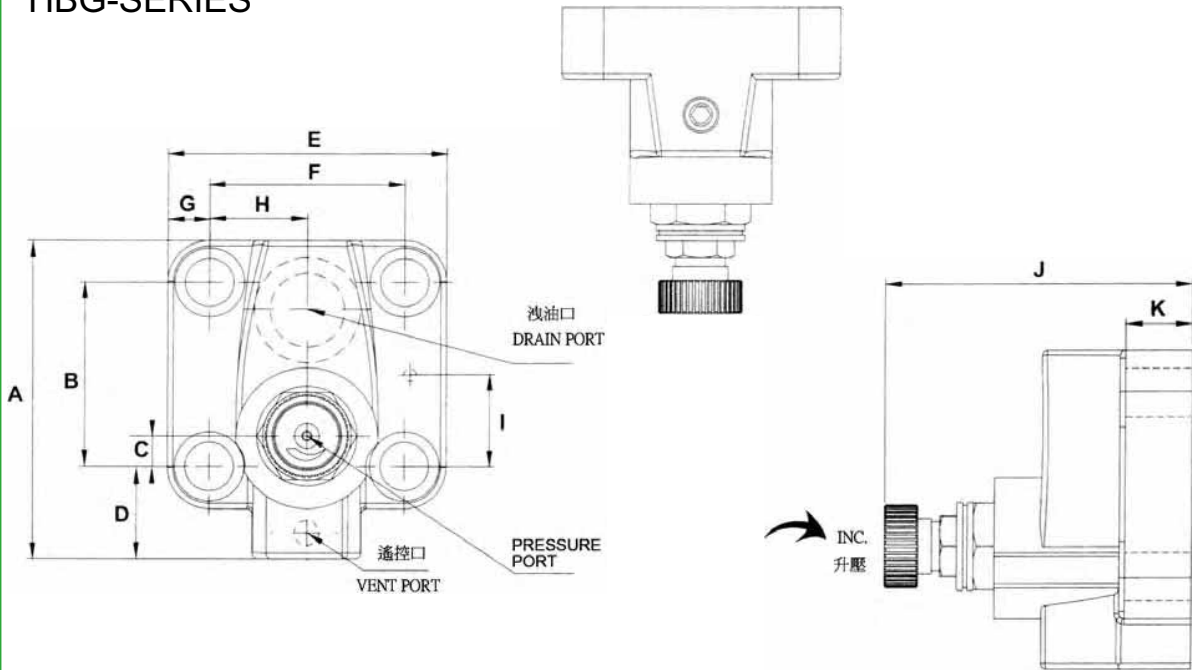

UNIT: M.M.(INCHES)

MODEL	A	B	C	D	E	F	G	H	I	J	K
HBG-03	97(3.81)	53.8(2.11)	22(0.86)	25.1(0.98)	84(3.30)	53.8(2.11)	15(0.59)	26.9(1.05)	22(0.86)	118(4.64)	26(1.02)
HBG-06	115(4.52)	66.5(2.61)	11(0.43)	33.5(1.31)	100(3.93)	70(2.75)	15(0.59)	35(1.37)	33.3(1.31)	118(4.64)	24(0.94)

DIMENSIONS

HBT-SERIES

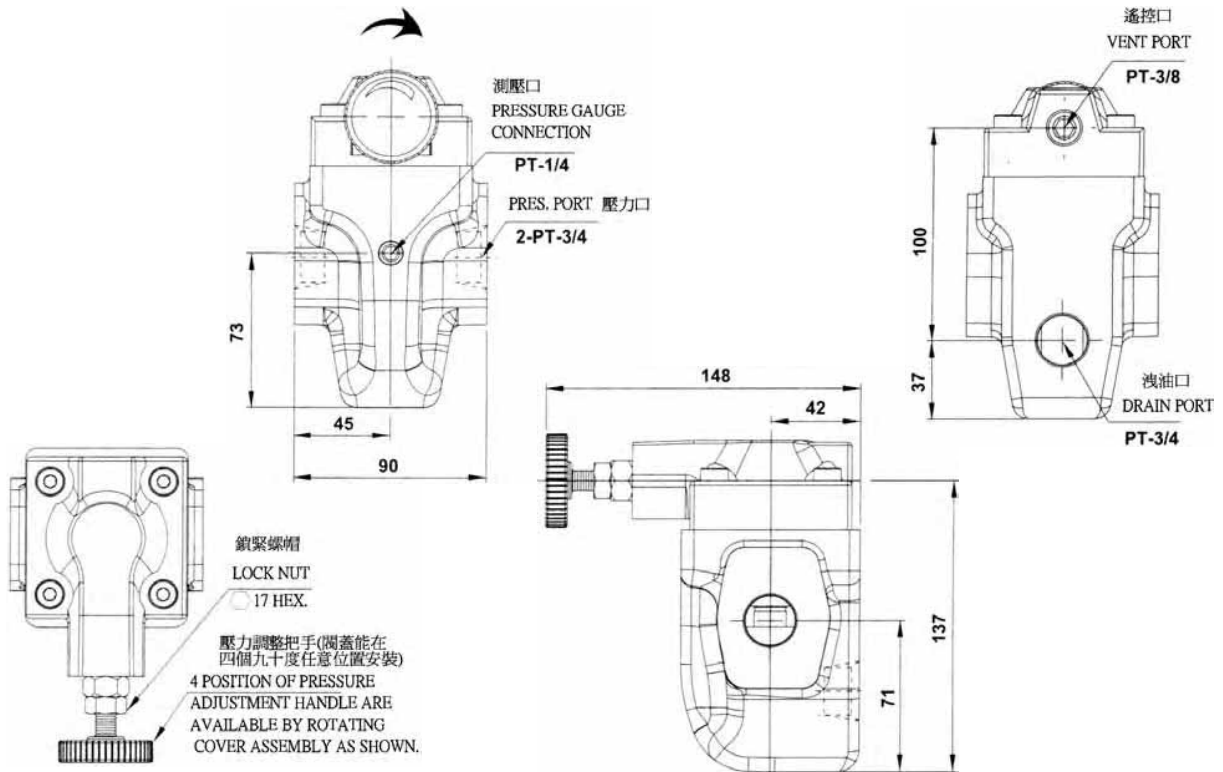



SOLTECH

PRESSURE CONTROLS

PILOT OPERATED RELIEF VALVES

【DBG/DBT-03】

※SPECIFICATION

MODEL	SIZE	MAX. PRES. MPa(PSt)	MAX. FLOW ℓ/min(GPM)	WEIGHT (Kg)
DBG	03	25 (3630)	40(10.5)	2.5
DBT	06			5.2

DBG-03

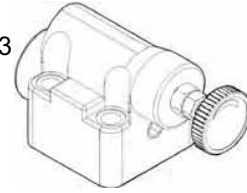

※MODEL NUMBER DESIGNATION

DB	G	03	B	(90)
SERIES NO.	CONNECTION TYPE G: SUB-PLATE TYPE T: THREADED TYPE	VALVE SIZE 03: 3/8"	PRESSURE ADJ. RANGE MPa(PSI) B:0.7~7(101.5~1015) C:3.5~14(507.5~2030) H:7~25(1015~3630)	DESIGN No. OMIT: DIN 912 BOLTS 90: UNC BOLTS (NORTH AMERICA)

DBT-03

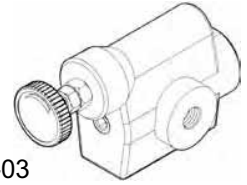

※ACCESSORIES

MODEL	SOCKET HEAD SCREW CAP			O RING			
	European Design. Std.	N. America Design Std.					
DBG-03	M10×55L	3/8-16UNC × 2-1/4 Lg.	4 Pcs	P9	1 Pcs	P18	2 Pcs

※GRAPHIC SYMBOL

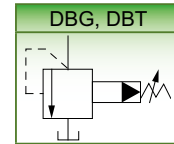

※PRODUCTS LIST

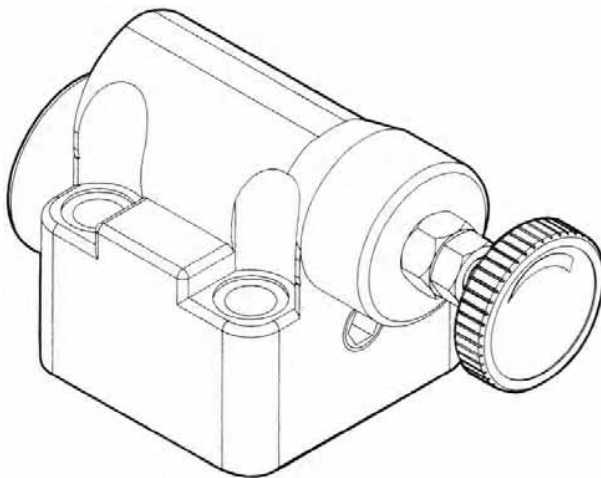

DBG-03

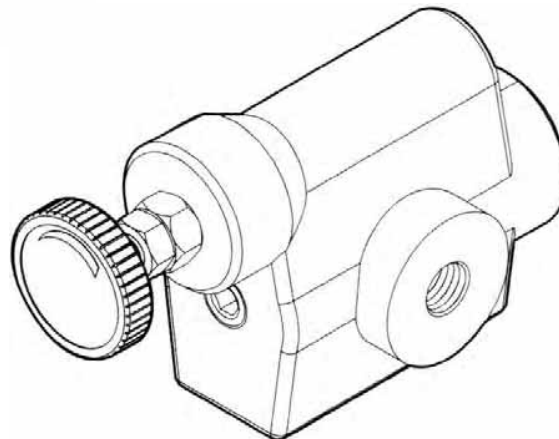

DBT-03



SOLTECH

PRESSURE CONTROLS

PILOT OPERATED RELIEF VALVES

C

DIMENSIONS

DBG-SERIES

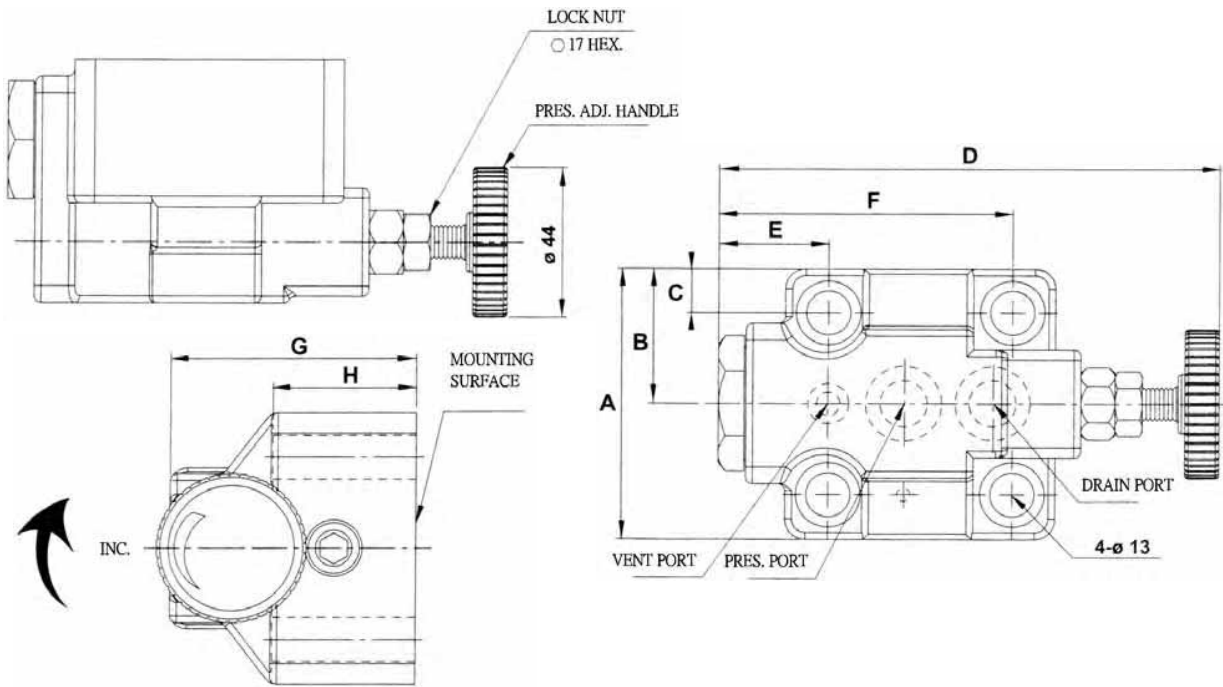

UNIT: M.M.(INCHES)

MODEL	A	B	C	D	E	F	G	H
DBG-03	80(3.14)	(40(1.57))	13(0.51)	165(6.49)	89(.50)	35(1.37)	87(3.42)	42(1.65)

DIMENSIONS

DBT-SERIES

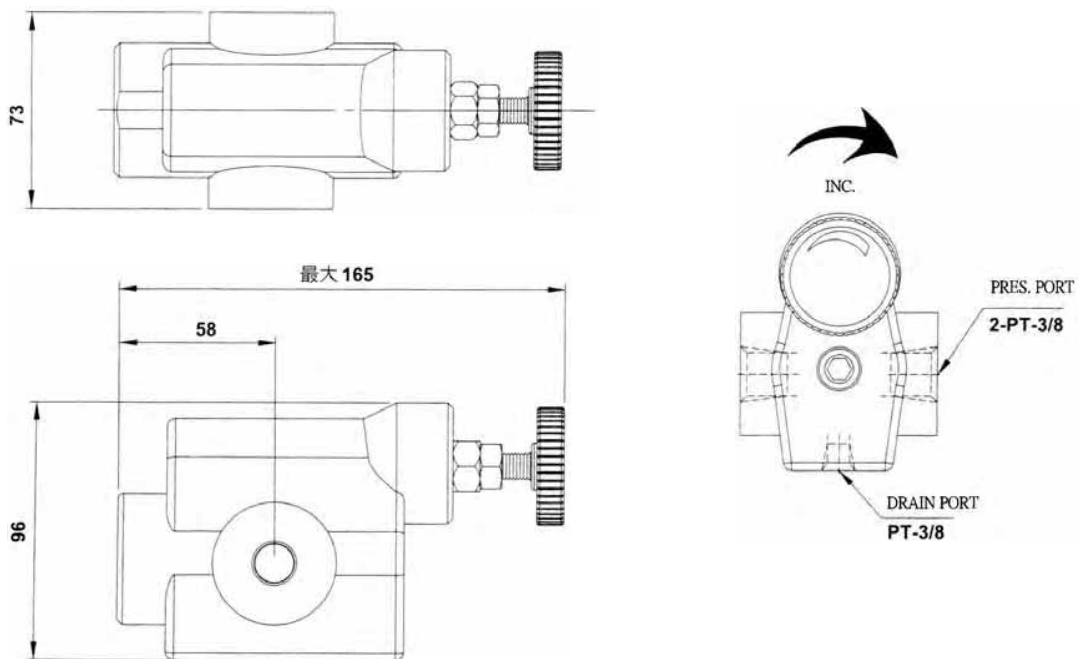



SOLTECH

PRESSURE CONTROLS

SOLENOID PILOT OPERATED RELIEF VALVES

[BSG/BST-03,06,10]

※SPECIFICATION

MODEL	SIZE	MAX. PRES. MPa(PSI)	MAX. FLOW ℓ/min(GPM)	WEIGHT (Kg)	
				BST	BSG
BSG, BST	03	25 (3630)	100(26.4)	4.6	5.6
	06		200(52.8)	4.6	7
	10		400(105.6)	9.4	10.8

BSG-03



BST-03

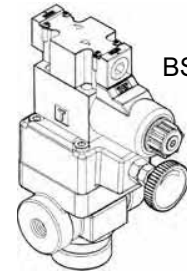

※ACCESSORIES

MODEL	SOCKET HEAD SCREW CAP						O RING			
	European Design. Std.	N. America Design Std.		European Design. Std.	N. America Design Std.					
BSG-03	M12×70L	1/2-13UNC × 2-3/4 Lg.	2 Pcs	M12×95L	1/2-13UNC × 3-3/4 Lg.	2 Pcs	P9	1 Pcs	P20	2 Pcs
BSG-06	M16×60L	5/8-11UNC × 2-1/4 Lg.	2 Pcs	M16×80L	5/8-11UNC × 3-1/4 Lg.	2 Pcs	P10A	1 Pcs	P29	2 Pcs
BSG-10	M20×70L	3/4-10UNC × 2-3/4 Lg.	2 Pcs	M20×90L	3/4-10UNC × 3-1/2 Lg.	2 Pcs	P10A	1 Pcs	P36	2 Pcs

※MODEL NUMBER DESIGNATION

BS	G	03	B	(2P)	(90)
SERIES NO.	CONNECTION TYPE G: SUB-PLATE TYPE T: THREADED TYPE	VALVE SIZE (Rc/PT) 03: 3/8", 6264-AR-06-2-A 04: 1/2" 06: 3/4", 6264-AS-08-2-A 10: 1(1/4)", 6264-AT-10-2-A	PRESSURE ADJ. RANGE B:0.7~7(101.5~1015) C:3.5~14(507.5~2030) H:7~25(1015~3630)	OMIT: SINGLE PRESSURE CONTROL 2P: DUOPRESSURE CONTROL 3P: TRIPRESSURE CONTROL	DESIGN No. OMIT: DIN 912 BOLTS 90: UNC BOLTS (NORTH AMERICA)

※PILOT VALVES DESIGNATION

Vent Type	Graphic Symbols	Sol. Oper. Dir. Valve Model No.	Operation		
			SOL "a"	SOL "b"	Vent Connecting
2B3A		SWG-02-2B3A	---	OFF	Connected to port "A".
			---	ON	Connected to tank (no-load)
2B3B		SWG-02-2B3B	---	OFF	Connected to tank (no-load)
			---	ON	Connected to port "B".
2B2B		SWG-02-2B2B	---	OFF	Closed state (relief valve setting pressure)
			---	ON	Connected to port "B".
2B2		SWG-02-2B2	---	OFF	Connected to port "A".
			---	ON	Connected to port "B".
3C2		SWG-02-3C2	OFF	OFF	Closed state (relief valve setting pressure)
			ON	OFF	Connected to port "A".
			OFF	ON	Connected to port "B".
3C3		SWG-02-3C3	OFF	OFF	Connected to tank (no-load)
			ON	OFF	Connected to port "A".
			OFF	ON	Connected to port "B".

※GRAPHIC SYMBOL

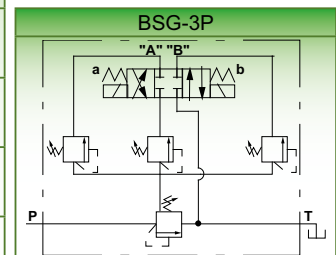
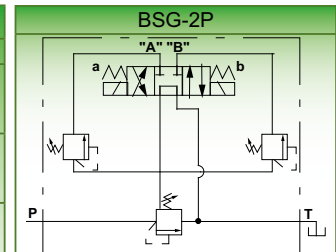



SOLTECH

PRESSURE CONTROLS

SOLENOID PILOT OPERATED RELIEF VALVES

C

DIMENSIONS

BSG-SERIES

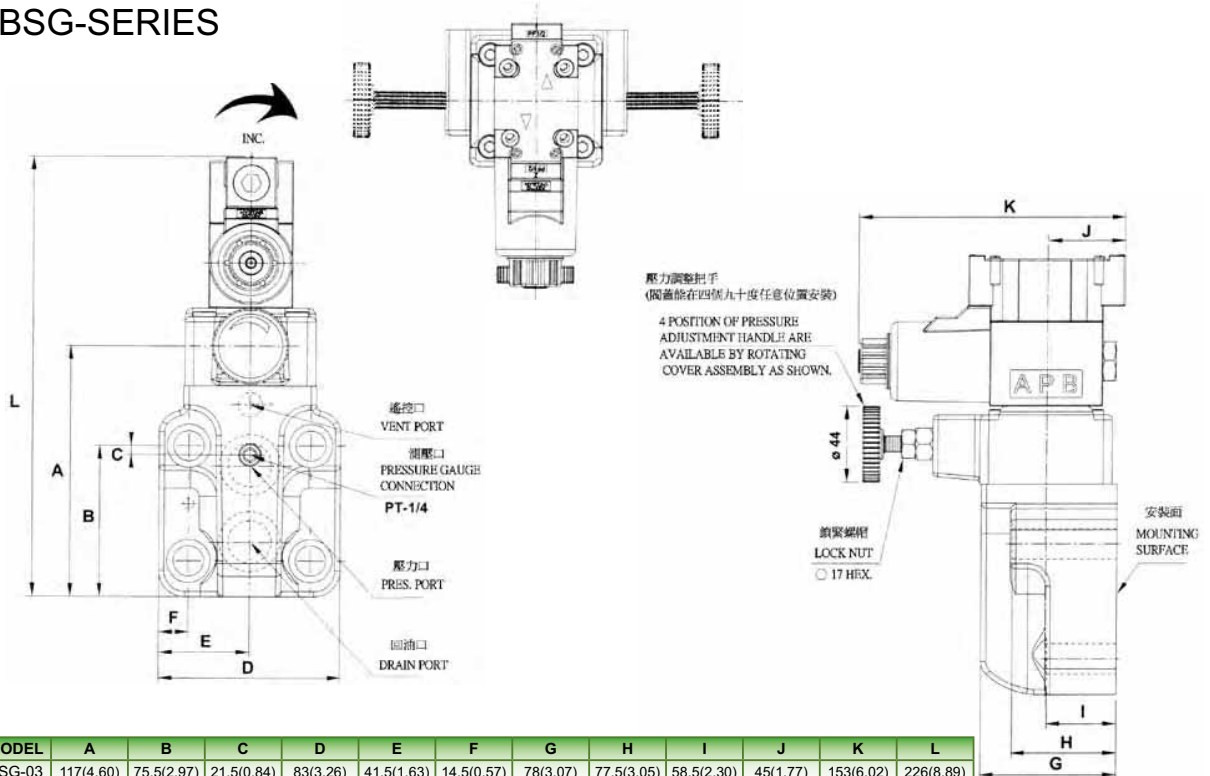

MODEL	A	B	C	D	E	F	G	H	I	J	K	L
BSG-03	117(4.60)	75.5(2.97)	21.5(0.84)	83(3.26)	41.5(1.63)	14.5(0.57)	78(3.07)	77.5(3.05)	58.5(2.30)	45(1.77)	153(6.02)	226(8.89)
BSG-06	145(5.70)	87.5(3.44)	5.5(0.21)	104(4.09)	52(2.04)	17(0.66)	78(3.07)	60(2.36)	40(1.57)	45(1.77)	153(6.02)	255(10.0)
BSG-10	175(6.88)	106(4.17)	8(0.31)	125(4.92)	62.5(2.46)	21.2(0.83)	90(3.54)	69.5(2.73)	49.5(1.94)	50(1.96)	153(6.02)	285(11.2)

DIMENSIONS

BST-SERIES

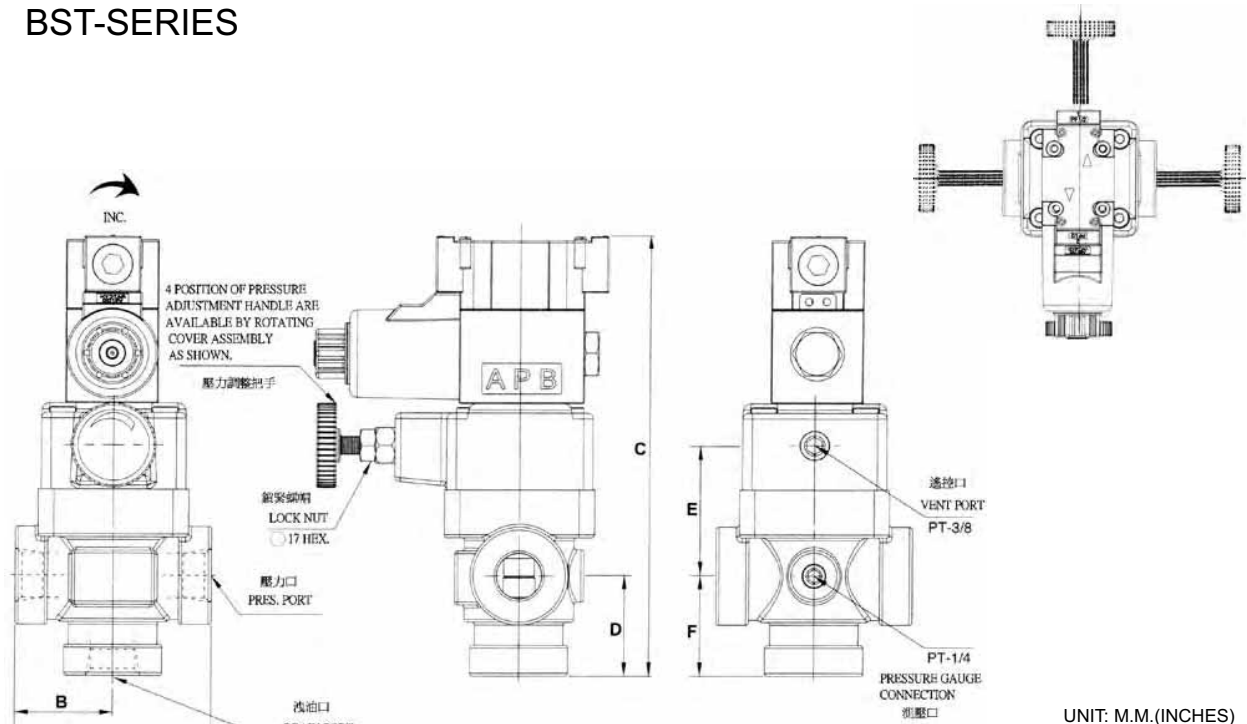

MODEL	A	B	C	D	E	F
BST-03	102(4.01)	51(2.00)	230(9.05)	52(2.04)	68(2.67)	52(2.04)
BST-06	120(4.72)	51(2.00)	230(9.05)	52(2.04)	68(2.67)	52(2.04)
BST-10	140(5.51)	70(2.75)	284(11.1)	84(3.30)	86(3.38)	82(3.22)



SOLTECH

PRESSURE CONTROLS

SOLENOID PILOT OPERATED RELIEF VALVES

DIMENSIONS

BSG-2P

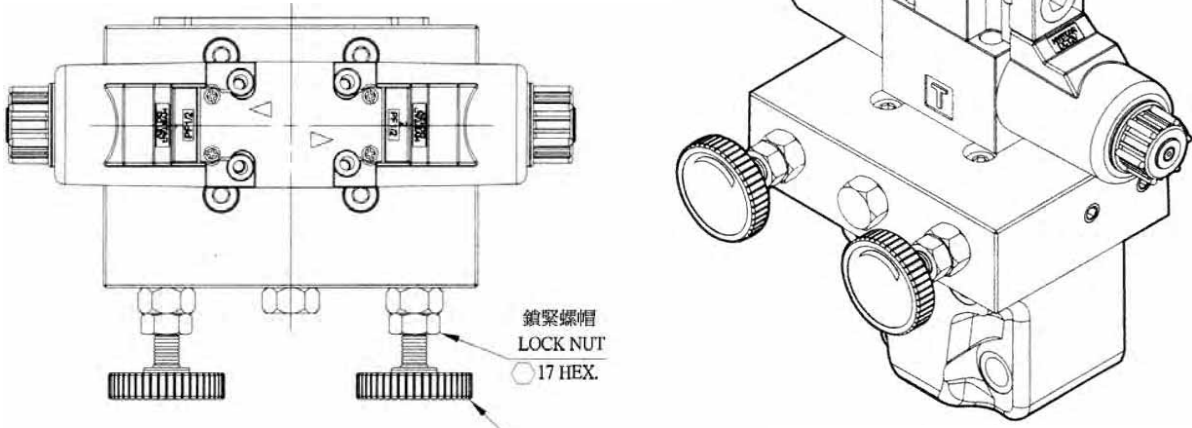

鎖緊螺帽
LOCK NUT
○17 HEX.

4 POSITION OF PRESSURE
ADJUSTMENT HANDLE ARE
AVAILABLE BY ROTATING
COVER ASSEMBLY AS SHOWN.

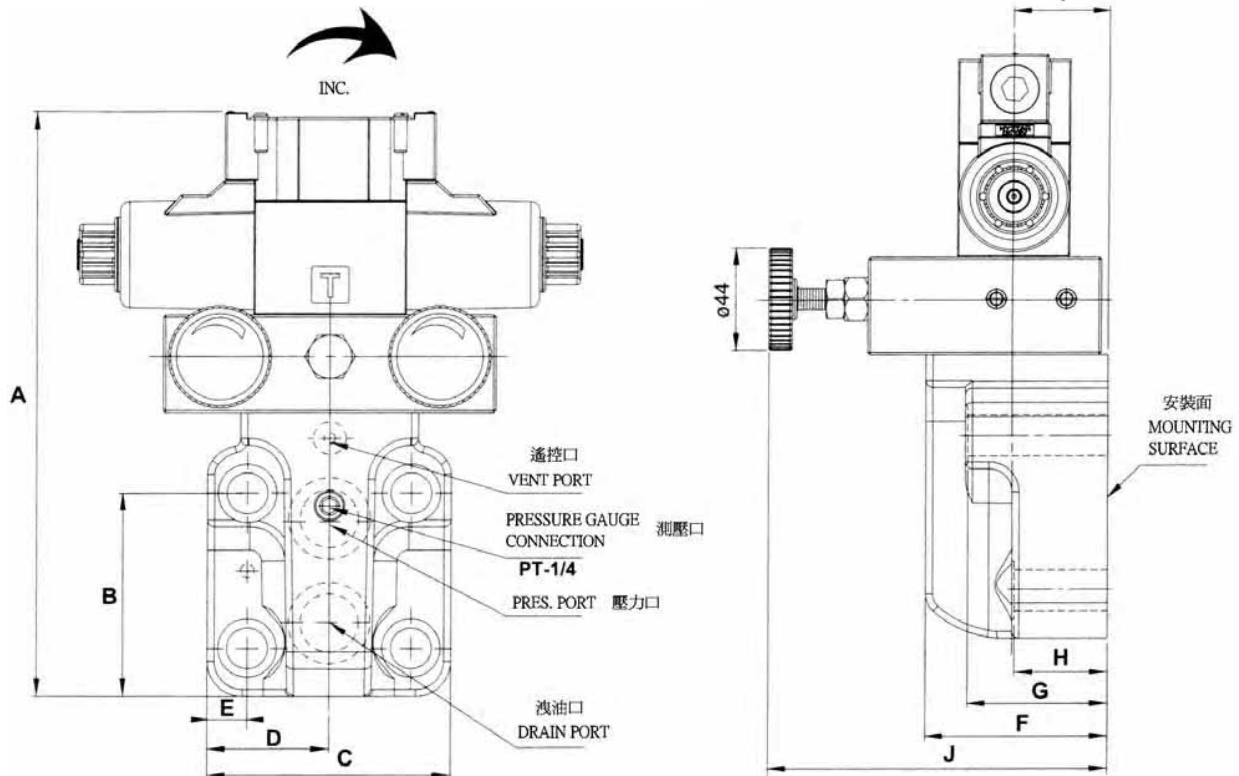

MODEL	A	B	C	D	E	F	G	H	I	J
BSG-03-2P	224	75.5	83	41.5	14.5	70	77.5	40	41	146
BSG-06-2P	251.5	87.5	104	52	17	78	60	40	41	146
BSG-10-2P	289.5	106	125	62.5	21.2	83	69.5	49.5	46	280

UNIT: M.M.

C



SOLTECH

PRESSURE CONTROLS

LOW NOISE PILOT OPERATIONAL RELIEF VALVES

[SBG-03,06,10]

※SPECIFICATION

MODEL	SIZE	MAX. PRES MPa (PSI)	MAX. FLOW ℓ/min(GPM)	WEIGHT (Kg)	
				SBT	SBG
SBG	03	25 (3630)	100(26.4)	2.5	5
	06		200(52.8)	3.5	6.2
	10		400(105.6)	9	9.5

※GRAPHIC SYMBOL

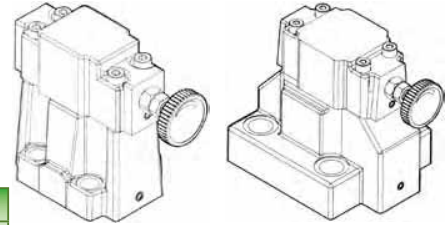
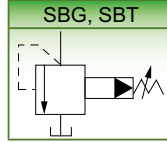

SBG-03

SBG-10

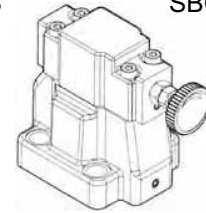

SBG-06

※MODEL NUMBER DESIGNATION

SB	G	03	B	(90)
SERIES NO.	CONNECTION TYPE G: SUB-PLATE TYPE	VALVE SIZE 03: 3/8", 6264-AR-06-2-A 04: 1/2" 06: 3/4", 6264-AS-08-2-A 10: 1(1/4)", 6264-AT-10-2-A	PRESSURE ADJ. RANGE MPa(psi) B:0.7~7(101.5~1015) C:3.5~14(507.5~2030) H:7~25(1015~3630)	DESIGN No. OMIT: DIN 912 BOLTS 90: UNC BOLTS (NORTH AMERICA)

※ACCESSORIES

MODEL	SOCKET HEAD SCREW CAP		O RING					
	European Design. Std.	N. America Design Std.						
SBG-03	M12 × 40 L	1/2-13 UNC × 1-1/2 Lg..	4	Pcs P9	1	Pcs P20	2	Pcs
SBG-06	M16 × 50 L	5/8-11 UNC × 2 Lg.	4	Pcs P10A	1	Pcs P29	2	Pcs
SBG-10	M20 × 60 L	3/4-10 UNC × 2-1/4 Lg.	4	Pcs P10A	1	Pcs P36	2	Pcs

※PERFORMANCE CURVE

SBG-03

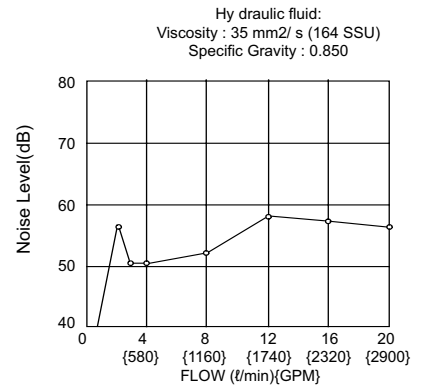
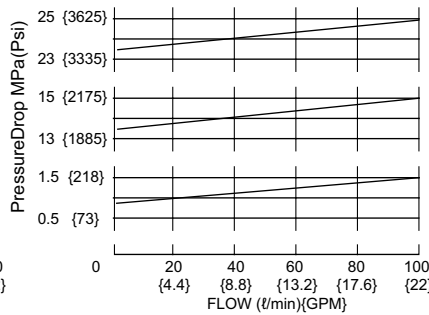
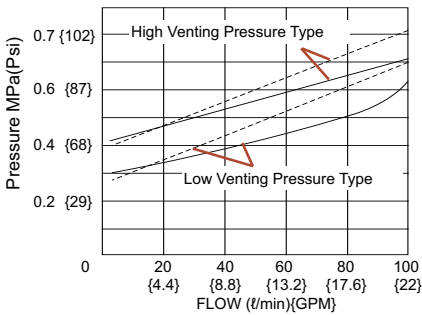

SBG-06

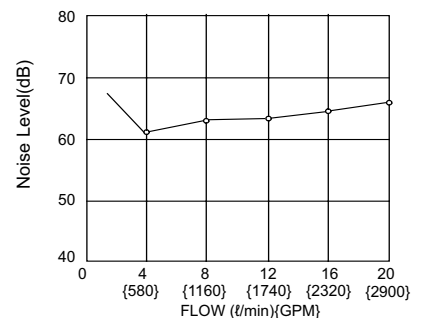
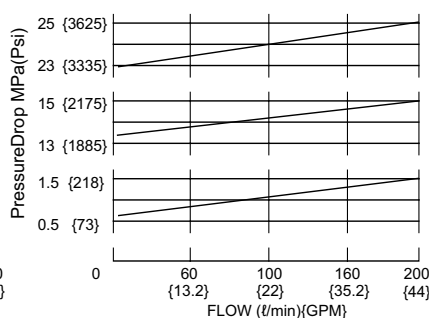
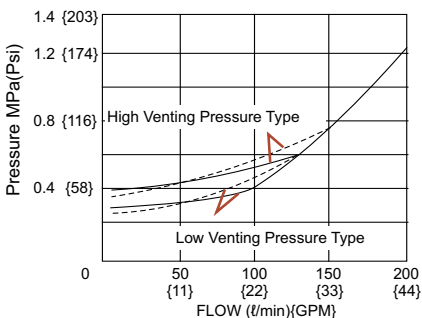

SBG-10

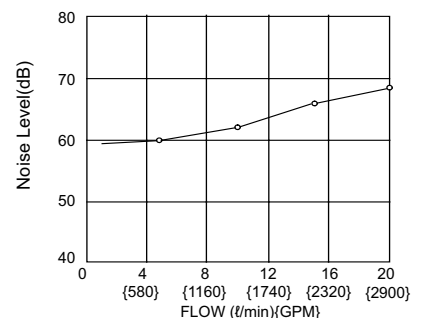
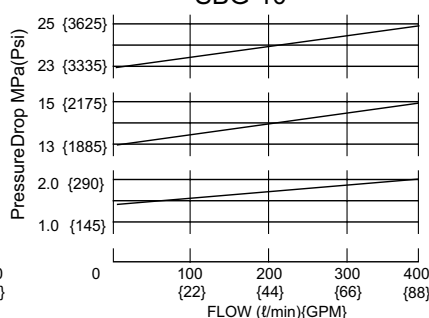
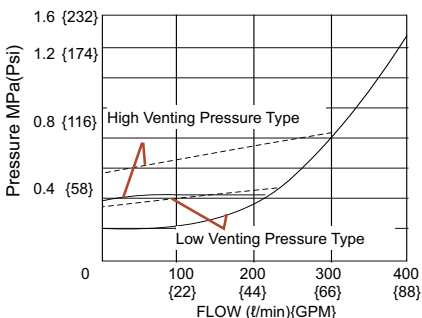



SOLTECH

PRESSURE CONTROLS

LOW NOISE PILOT OPERATIONAL RELIEF VALVES

DIMENSIONS

SBG

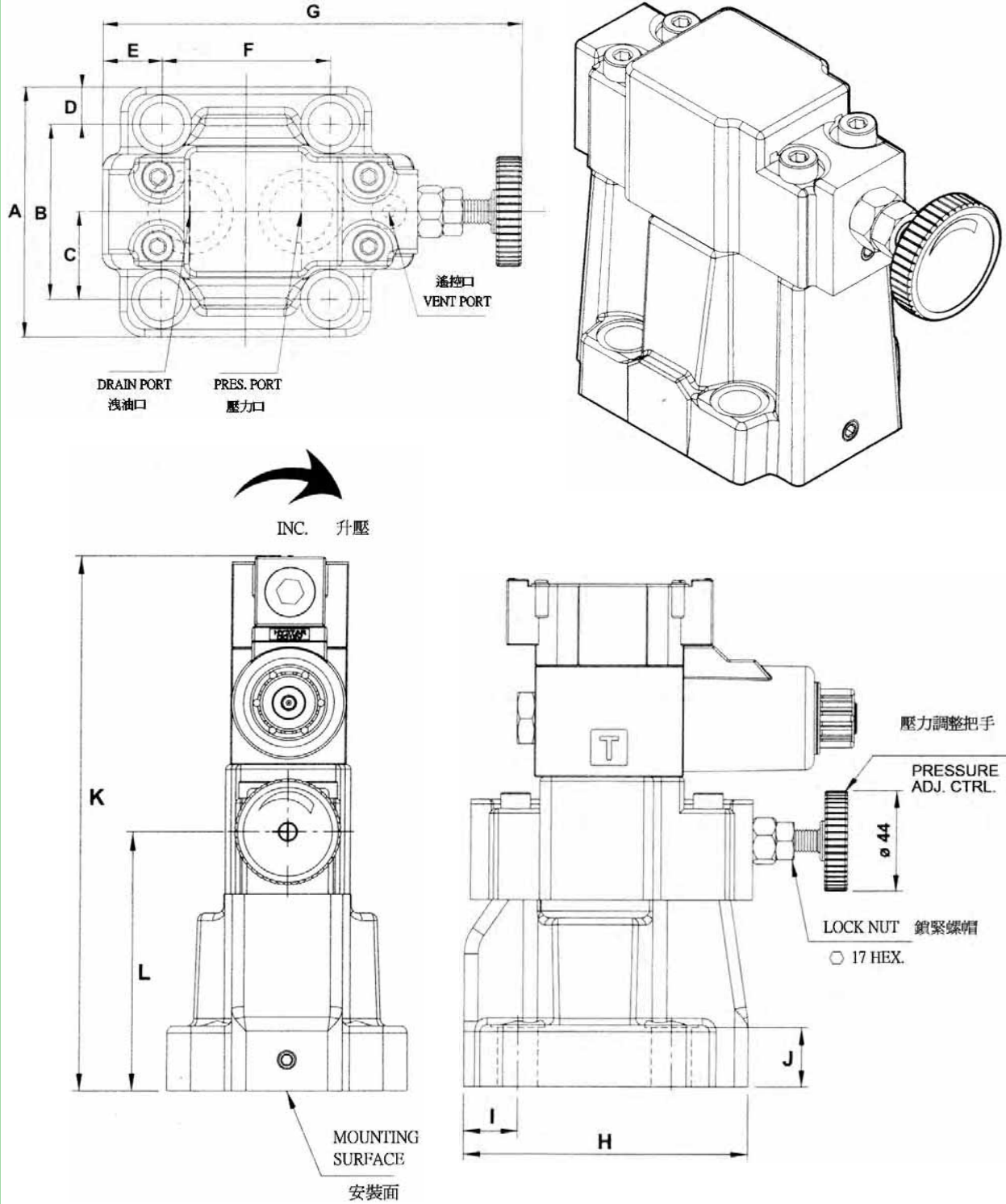

UNIT: M.M.(INCHES)

MODEL	A	B	C	D	E	F	G	H	I	J	K	L
SBG-03	78(3.07)	54(2.12)	27(1.06)	12(0.47)	34.5(1.35)	54(2.12)	165(6.49)	107(4.21)	26.5(1.04)	23(0.90)	134(5.27)	106(4.25)
SBG-06	100(3.93)	70(2.75)	35(1.37)	15(0.59)	23.5(0.92)	67(2.63)	167(6.57)	124(4.88)	23.5(0.92)	26(1.02)	136(5.35)	108(4.25)
SBG-10	127(5.00)	82.6(3.25)	41.3(1.62)	22.2(0.87)	20.5(0.80)	89(3.50)	185(7.28)	155(6.10)	20.5(0.80)	36(1.41)	145(5.70)	120(4.72)

【SBSG-03,06,10】

※SPECIFICATION

MODEL	SIZE	MAX. PRES MPa (PSI)	MAX. FLOW ℓ/min(GPM)	WEIGHT (Kg)
SBSG, SBST	03	25 (3630)	100(26.4)	5
	06		200(52.8)	6.2
	10		400(105.6)	9.5

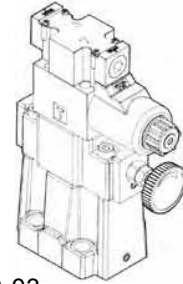

SBSG-03

※ACCESSORIES

MODEL	SOCKET HEAD SCREW CAP						O RING			
	European Design. Std.	N. America Design Std.		European Design. Std.	N. America Design Std.					
SBSG-03	M12×70L	1/2-13UNC × 2-3/4 Lg.	2 Pcs	M12×95L	1/2-13UNC × 3-3/4 Lg.	2 Pcs	P9	1 Pcs	P20	2 Pcs
SBSG-06	M16×60L	5/8-11UNC × 2-1/4 Lg.	2 Pcs	M16×80L	5/8-11UNC × 3-1/4 Lg.	2 Pcs	P10A	1 Pcs	P29	2 Pcs
SBSG-10	M20×70L	3/4-10UNC × 2-3/4 Lg.	2 Pcs	M20×90L	3/4-10UNC × 3-1/2 Lg.	2 Pcs	P10A	1 Pcs	P36	2 Pcs

※MODEL NUMBER DESIGNATION

SBS	G	03	B	R	(90)
SERIES NO.	CONNECTION TYPE G: SUB-PLATE TYPE	VALVE SIZE 03: 3/8", 6264-AR-06-2-A 04: 1/2" 06: 3/4", 6264-AS-08-2-A 10: 1(1/4)", 6264-AT-10-2-A	PRESSURE ADJ. RANGE MPa(psi) B:0.7~7(101.5~1015) C:3.5~14(507.5~2030) H:7~25(1015~3630)	DIRECTION OF HANDLE (Viewed from pressure gauge Connection) L: Left (Normal) R: Right	DESIGN No. OMIT: DIN 912 BOLTS 90: UNC BOLTS (NORTH AMERICA)

※MODEL NUMBER DESIGNATION

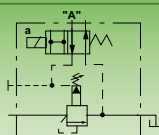
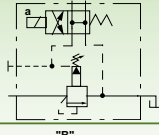
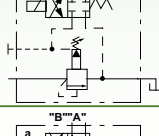
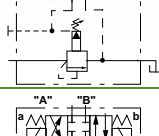
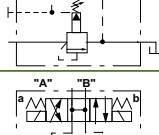
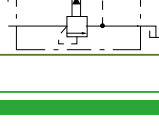
Vent Type	Graphic Symbols	Sol. Oper. Dir. Valve Model No.	Operation		
			SOL "a"	SOL "b"	Vent Connecting
2B3A		SWG-02-2B3A	---	OFF	Connected to port "A".
			---	ON	Connected to tank (no-load)
2B3B		SWG-02-2B3B	---	OFF	Connected to tank (no-load)
			---	ON	Connected to port "B".
2B2B		SWG-02-2B2B	---	OFF	Closed state (relief valve setting pressure)
			---	ON	Connected to port "B".
2B2		SWG-02-2B2	---	OFF	Connected to port "A".
			---	ON	Connected to port "B".
3C2		SWG-02-3C2	OFF	OFF	Closed state (relief valve setting pressure)
			ON	OFF	Connected to port "A".
			OFF	ON	Connected to port "B".
3C3		SWG-02-3C3	OFF	OFF	Connected to tank (no-load)
			ON	OFF	Connected to port "A".
			OFF	ON	Connected to port "B".

DIMENSIONS

S-BSG

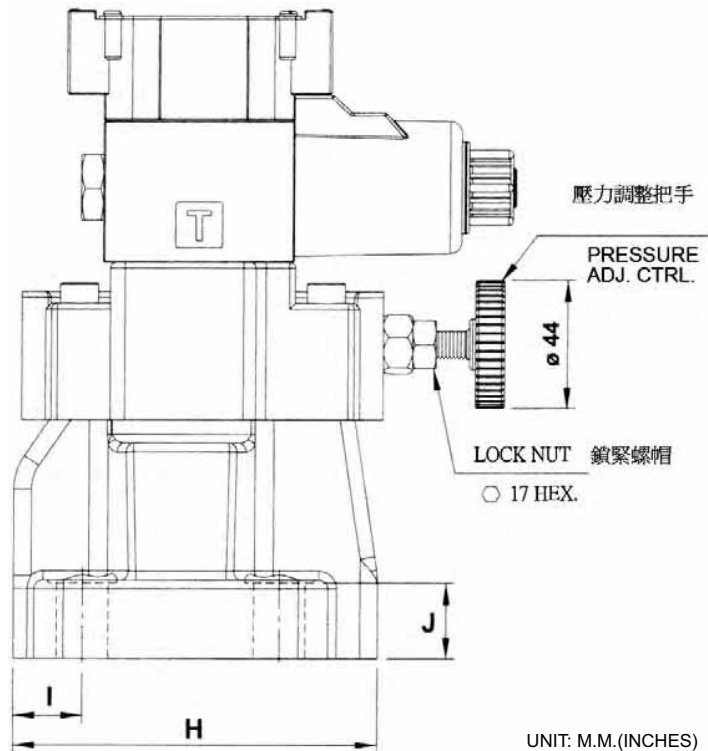
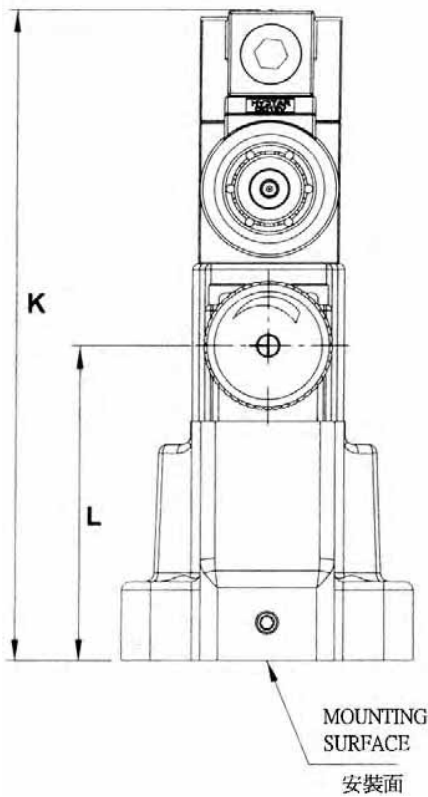
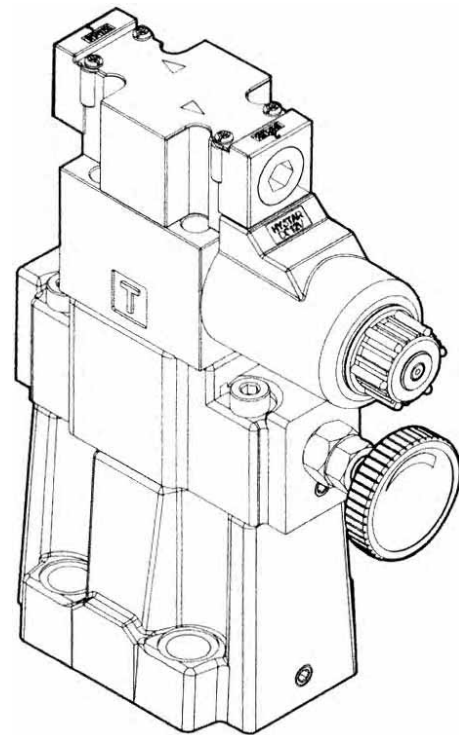
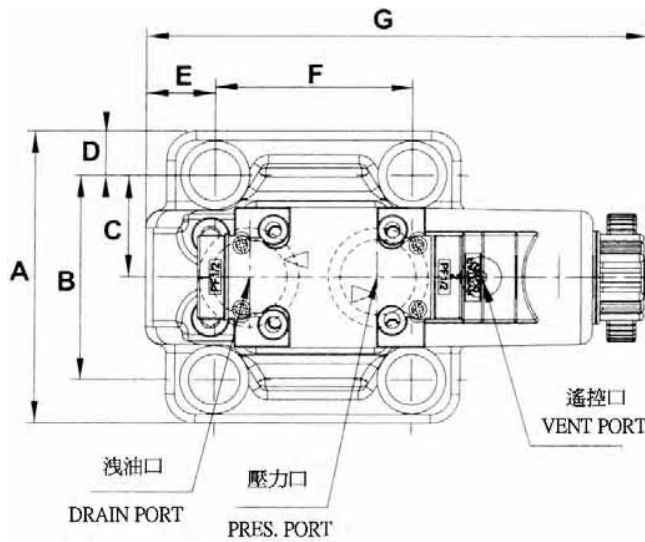

UNIT: M.M.(INCHES)

MODEL	A	B	C	D	E	F	G	H	I	J	K
S-BSG-03	78(3.07)	54(2.12)	27(1.06)	12(0.47)	34.5(1.35)	54(2.12)	169(6.65)	107(4.21)	26.5(1.04)	23(0.90)	222(8.74)
S-BSG-06	100(3.93)	70(2.75)	35(1.37)	15(0.59)	23.5(0.92)	67(2.63)	171(6.73)	124(4.88)	23.5(0.92)	26(1.02)	224(8.81)
S-BSG-10	127(5.00)	82.6(3.25)	41.3(1.61)	22.2(0.87)	20.5(0.80)	89(3.50)	190(7.48)	155(6.10)	20.5(0.80)	36(1.41)	273(10.7)



SOLTECH

PRESSURE CONTROLS

UNLOADING RELIEF VALVES

[BUCG-06]

※SPECIFICATION

MODEL	SIZE	MAX. PRES MPa (PSI)	MAX. FLOW ℓ/min(GPM)	WEIGHT (Kg)
BUCG	06	25 (3630)	125(33)	12

※MODEL NUMBER DESIGNATION

BUC	G	06	B	(90)
SERIES NO.	CONNECTION TYPE G: SUB-PLATE TYPE	VALVE SIZE 06: 3/4"	PRESSURE ADJ. RANGE MPa(psi) B:0.7~7(101.5~1015) C:3.5~14(507.5~2030) H:7~25(1015~3630)	DESIGN No. OMIT: DIN 912 BOLTS 90: UNC BOLTS (NORTH AMERICA)

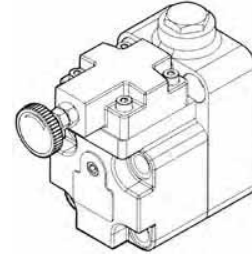

※ACCESSORIES

MODEL	SOCKET HEAD SCREW CAP		O RING				
	European Design. Std.	N. America Design Std.					
BUCG-06	M16 × 130 L	5/8-11 UNC × 5 Lg..	4 Pcs	P9	1 Pcs	P29	2 Pcs
	M16 × 50 L	5/8-11 UNC × 2 Lg.	2 Pcs			P29	3 Pcs

※GRAPHIC SYMBOL

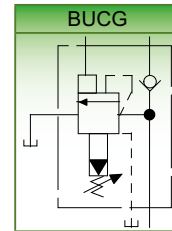

※PERFORMANCE CURVE

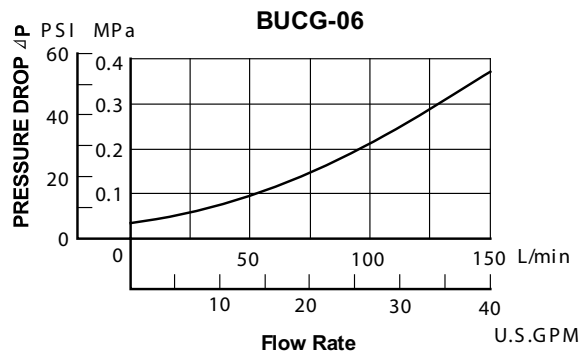
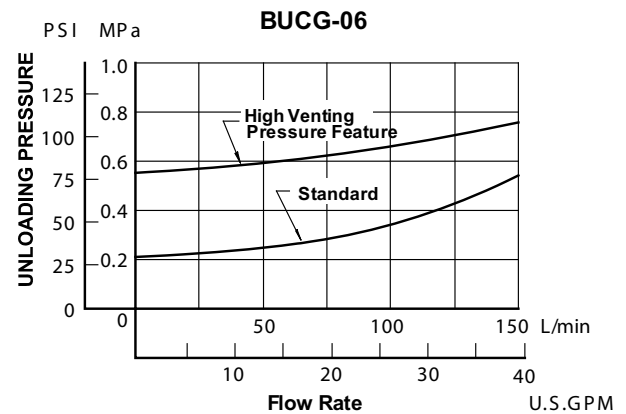
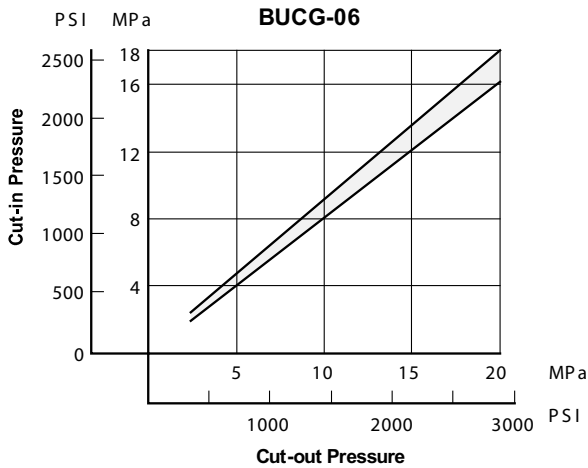



SOLTECH

PRESSURE CONTROLS UNLOADING RELIEF VALVES

DIMENSIONS

BUCG

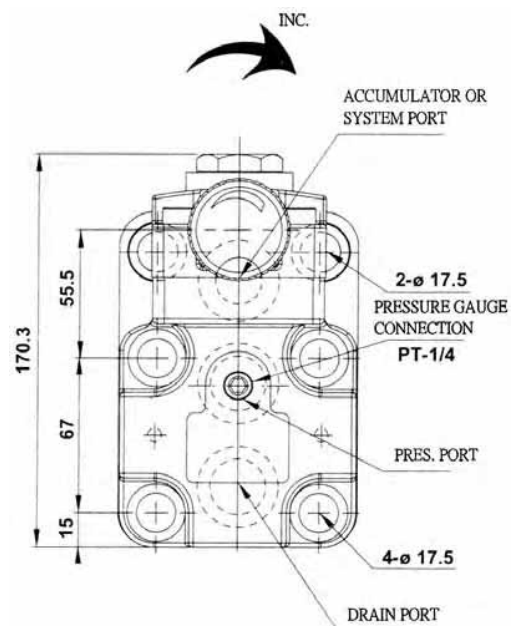
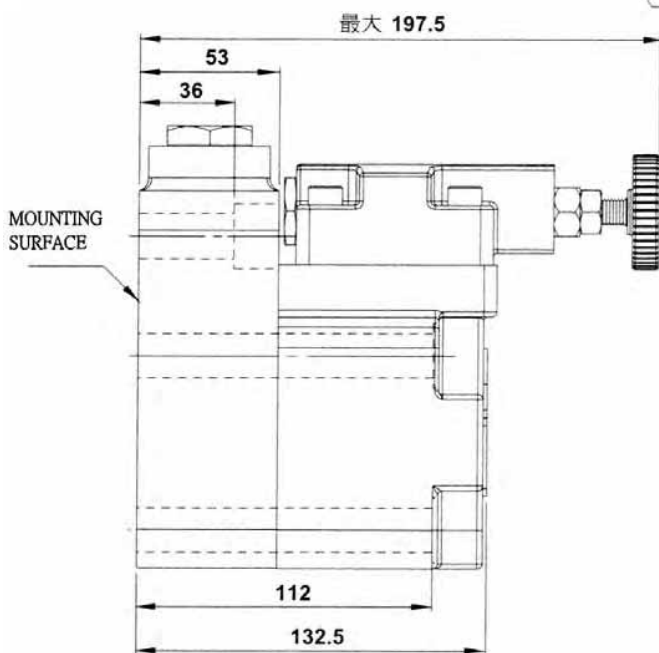
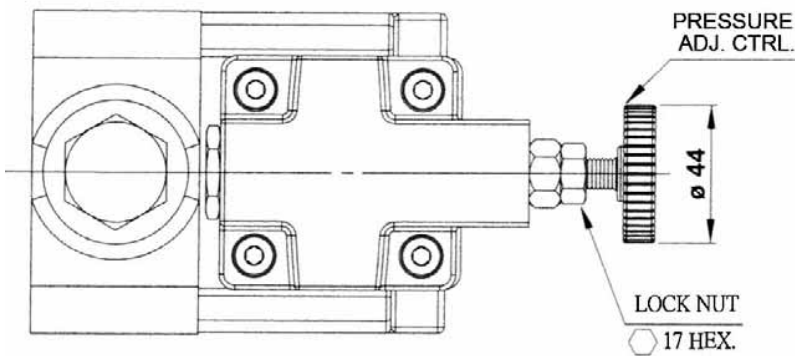
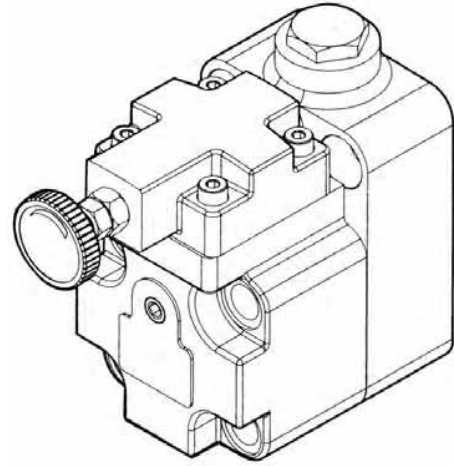
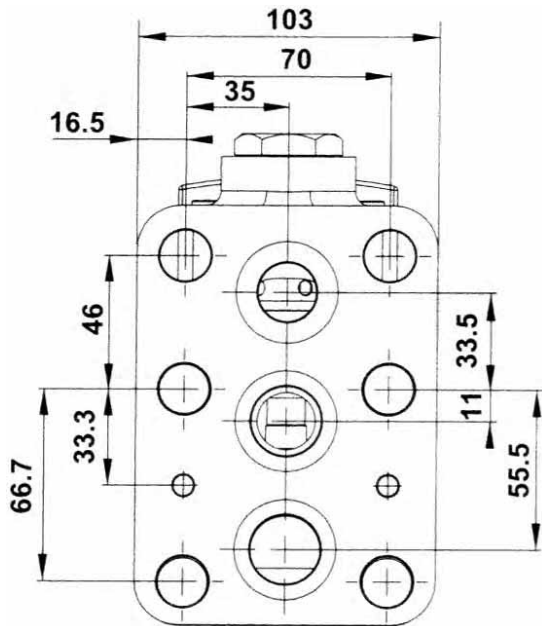

UNIT: M.M.(INCHES)

C



SOLTECH

PRESSURE CONTROLS

"H" TYPE PRESSURE CONTROL VALVES

[HG/HT-03, 06, 10]

※SPECIFICATION

MODEL	SIZE	MAX. PRES MPa (PSI)	MAX. FLOW ℓ/min(GPM)	WEIGHT (Kg)	
				HT	HG
HG, HT	03	21 (3050)	50 (13.2)	4	4
	06		125 (33)	6.6	6.5
	10		250 (66)	12	11

HG-03

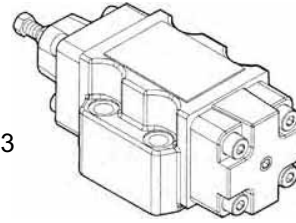

※ACCESSORIES

MODEL	SOCKET HEAD SCREW CAP			O RING			
	European Design. Std.	N. America Design Std.					
HG-03	M10 × 50 Lg.	3/8 -16 UNC × 2 Lg.	4 Pcs	P9	2 Pcs	P18	2 Pcs
HG-06	M10 × 50 Lg.	3/8 -16 UNC × 2 Lg.	4 Pcs	P9	2 Pcs	P29	2 Pcs
HG-10	M10 × 50 Lg.	3/8 -16 UNC × 2 Lg.	6 Pcs	P9	2 Pcs	P38	2 Pcs

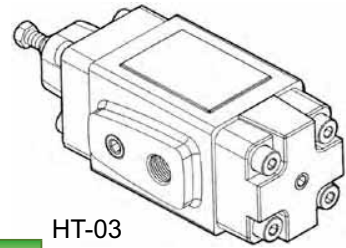

HT-03

※MODEL NUMBER DESIGNATION

H	G	03	B	(90)
SERIES NO.	CONNECTION TYPE G: SUB-PLATE TYPE T: THREADED TYPE	VALVE SIZE 03: 3/8", ISO 5781-AG-06-2-A 06: 3/4", ISO 5781-AH-08-2-A 10: 1(1/4)", ISO 5781-AJ-10-2-A	PRESSURE ADJ. RANGE MPa(PSI) A:1.8~3.5(261~507.5) B:0.7~7(101.5~1015) C:3.5~14(507.5~2030) H:7~21(1015~3045)	DESIGN No. OMIT: DIN 912 BOLTS 90: UNC BOLTS (NORTH AMERICA)

※MODEL NUMBER DESIGNATION

TYPE 1: LOW PRESSURE RELIEF VALVE		TYPE 2: SEQUENCE VALVE	
	Can be used as lowpressure relief valve, but be careful to occurrence of surge pressure.		Used to control the operational sequence of 2 or more actuators. If primary pressure exceeds the pressure setting, effective fluid is delivered to the secondary side.
	INTERNAL PILOT INTERNAL DRAIN		INTERNAL PILOT EXTERNAL DRAIN
TYPE 3: SEQUENCE VALVE		TYPE 4: UNLOADING VALVE	
	Used for the same purpose as for the type 2. Operated by external pilot pressure irrespective of primary pressure.		Used as unloading valve. If external pilot pressure exceeds the pressure setting, the pump is turned no-load by releasing all fluid to the tank.
	EXTERNAL PILOT EXTERNAL DRAIN		EXTERNAL PILOT INTERNAL DRAIN

C



SOLTECH

PRESSURE CONTROLS

"H" TYPE PRESSURE CONTROL VALVES

HG-SERIES

DIMENSIONS

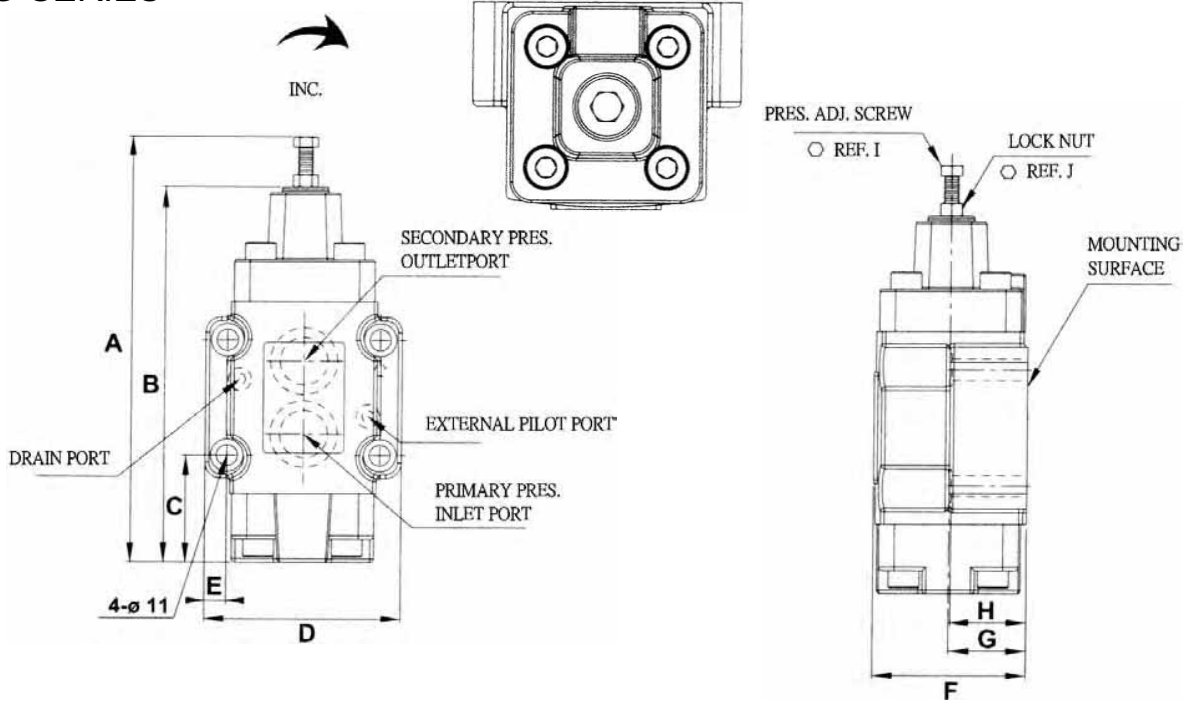

MODEL	A	B	C	D	E	F	G	H	I	J
HG-03	192(7.55)	168(6.61)	50.6(1.99)	89(3.50)	11.2(0.44)	69(2.71)	41(1.65)	35(1.37)	13(0.51)	13(0.51)
HG-06	223(8.77)	196(7.71)	60(2.36)	102(4.01)	11.3(0.44)	79(3.11)	40(1.57)	39(1.53)	13(0.51)	13(0.51)
HG-10	266(10.4)	239(9.40)	65(2.55)	119(4.48)	11(0.43)	96(3.77)	48.5(1.90)	40(1.57)	5(0.19)	17(0.66)

UNIT: M.M.(INCHES)

DIMENSIONS

HT-SERIES

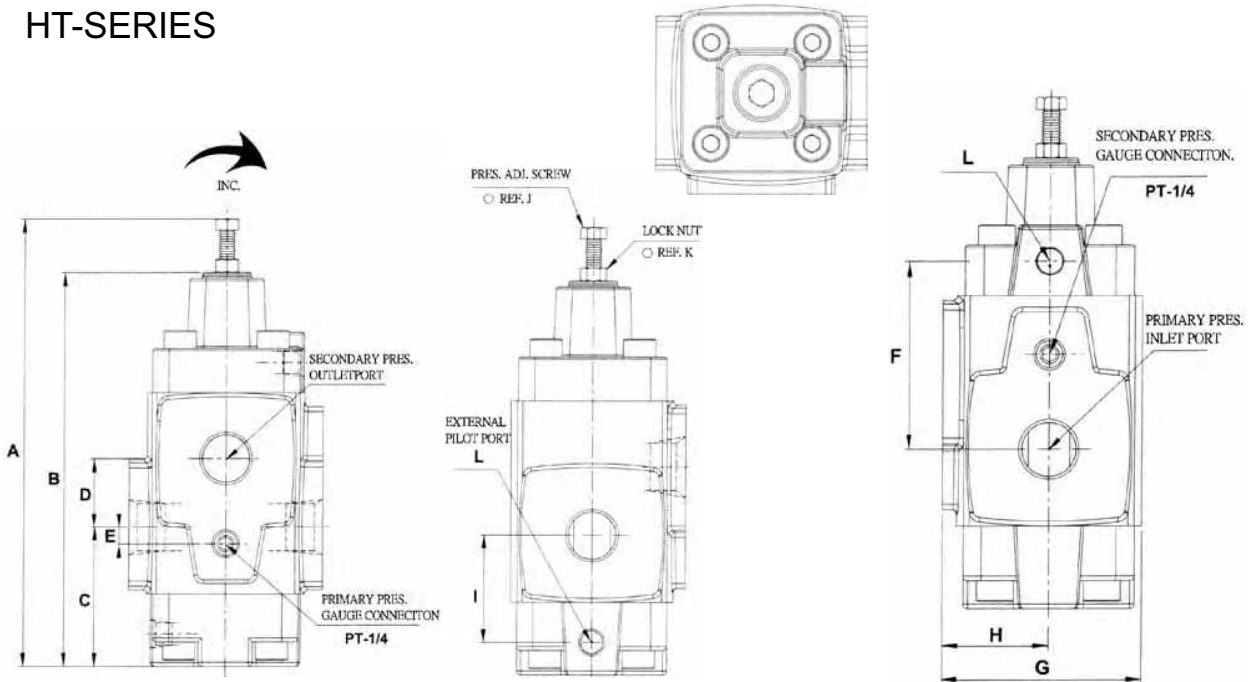

UNIT: M.M.(INCHES)

MODEL	A	B	C	D	E	F	G	H	I	J	K	L
HT-03	192(7.55)	167.5(6.59)	(58(2.28))	30(1.18)	0	69(2.71)	74(2.91)	41.5(1.63)	45(1.77)	13(0.51)	13(0.51)	1/8"
HT-06	223(8.77)	196(7.71)	69(2.71)	34(1.33)	8(0.31)	82(3.22)	86(3.38)	46(1.81)	53(2.08)	13(0.51)	13(0.51)	1/4"
HT-10	266(10.4)	239(9.40)	87(3.42)	41(1.61)	11(0.43)	58(2.28)	110(4.33)	65(2.55)	68(2.67)	5(0.19)	17(0.66)	1/4"



SOLTECH

PRESSURE CONTROLS

"HC" TYPE PRESSURE CONTROL VALVES

[HCG/HCT-03, 06, 10]

※SPECIFICATION

MODEL	SIZE	MAX. PRES MPa (PSI)	MAX. FLOW ℓ/min(GPM)	WEIGHT (Kg)	
				HCT	HCG
HCG, HCT	03	21 (3050)	50 (13.2)	4	5
	06		125 (33)	7.5	8
	10		250 (66)	14	13

※ACCESSORIES

MODEL	SOCKET HEAD SCREW CAP			O RING			
	European Design. Std.	N. America Design Std.					
HCG-03	M10 × 70 Lg.	1/2 -13 UNC × 1-1/2 Lg.	4 Pcs	P9	2 Pcs	P18	2 Pcs
HCG-06	M10 × 80 Lg.	3/8 -16 UNC × 3-1/4 Lg.	4 Pcs	P9	2 Pcs	P29	2 Pcs
HCG-10	M10 × 90 Lg.	3/8 -16 UNC × 3-1/2 Lg.	6 Pcs	P9	2 Pcs	P38	2 Pcs

※MODEL NUMBER DESIGNATION

H	C	G	03	B	(90)
SERIES NO.	WITH CHECK VALVE	CONNECTION TYPE G: SUB-PLATE TYPE T: THREADED TYPE	VALVE SIZE 03: 3/8", ISO 5781-AG-06-2-A 06: 3/4", ISO 5781-AH-08-2-A 10: 1(1/4)", ISO 5781-AJ-10-2-A	PRESSURE ADJ. RANGE MPa(PSI) A:1.8~3.5(261~507.5) B:0.7~7(101.5~1015) C:3.5~14(507.5~2030) H:7~21(1015~3045)	DESIGN No. OMIT: DIN 912 BOLTS 90: UNC BOLTS (NORTH AMERICA)

HCG-03

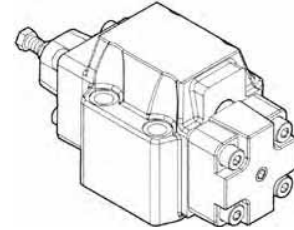

HCT-03

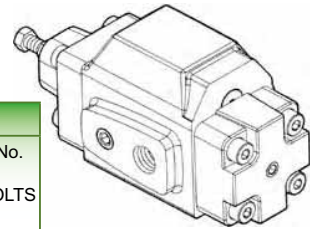

※MODEL NUMBER DESIGNATION

TYPE 1 : COUNTERBALANCE VALVE		TYPE 2 : SEQUENCE AND CHECK VALVE	
	Used to prevent gravitational falls by generating a pressure on the actuator return side. If primary pressure exceeds the pressure setting, fluid is released to keep the pressure constant.		Used to control the operating sequence of two or more actuators. If primary pressure exceeds the pressure setting, effective fluid is delivered to the secondary side. Reversed flow is free by a check valve.
	INTERNAL PILOT INTERNAL DRAIN		INTERNAL PILOT EXTERNAL DRAIN
TYPE 3 : SEQUENCE AND CHECK VALVE		TYPE 4 : COUNTERBALANCE VALVE	
	Used for the same purpose as for type 2. Operated by external pilot pressure irrespective of primary pressure. Reversed flow is free by a check valve.		Used for the same purpose as for type 1. Operated by external pilot pressure irrespective of primary pressure. Reversed flow is free by a check valve.
	EXTERNAL PILOT EXTERNAL DRAIN		EXTERNAL PILOT INTERNAL DRAIN

※PERFORMANCE CURVE

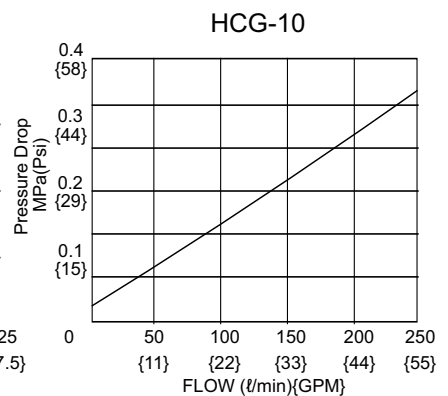
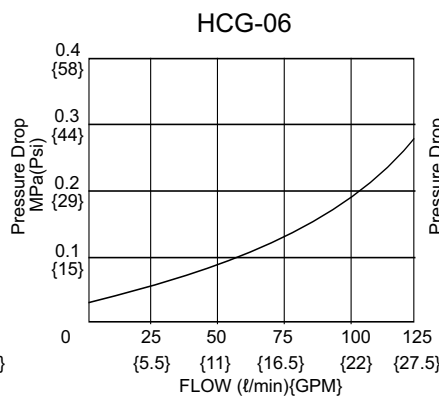
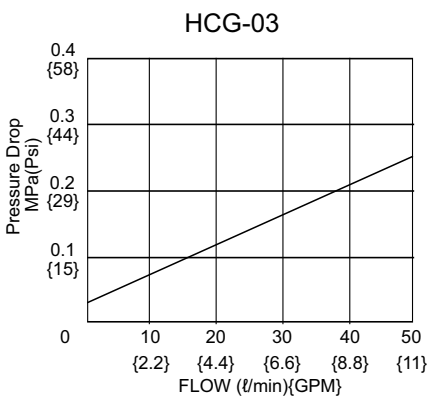



SOLTECH

PRESSURE CONTROLS

"HC" TYPE PRESSURE CONTROL VALVES

C

DIMENSIONS

HCG-SERIES

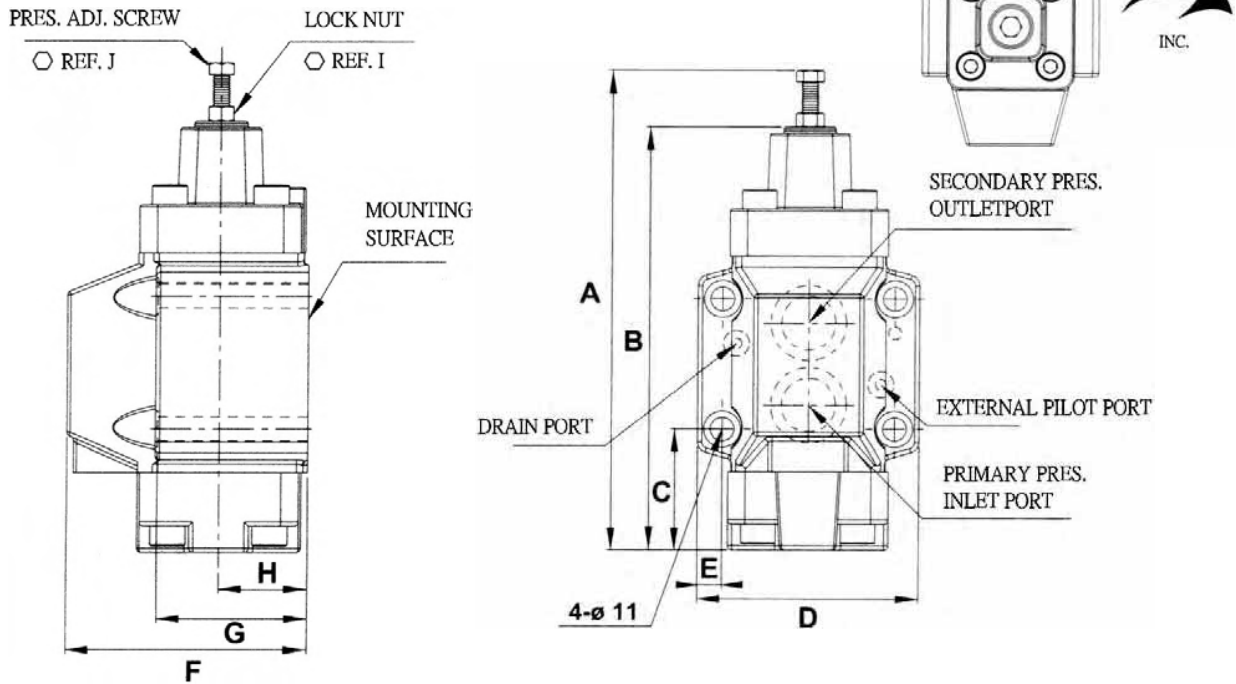

MODEL	A	B	C	D	E	F	G	H	I	J
HCG-03	192(7.55)	167.5(6.59)	50.6(1.99)	89(3.50)	11.2(0.44)	90(3.54)	58(2.28)	35(1.37)	13(0.51)	13(0.51)
HCG-06	222(8.74)	196(7.71)	60(2.36)	102(4.01)	11.3(0.44)	109(4.29)	68(2.67)	40(1.57)	13(0.51)	13(0.51)
HCG-10	266(10.4)	239(9.40)	65(2.55)	119(4.48)	11.1(0.43)	131(5.15)	80(3.14)	48(1.88)	5(0.19)	17(0.66)

UNIT: M.M.(INCHES)

DIMENSIONS

HCT-SERIES

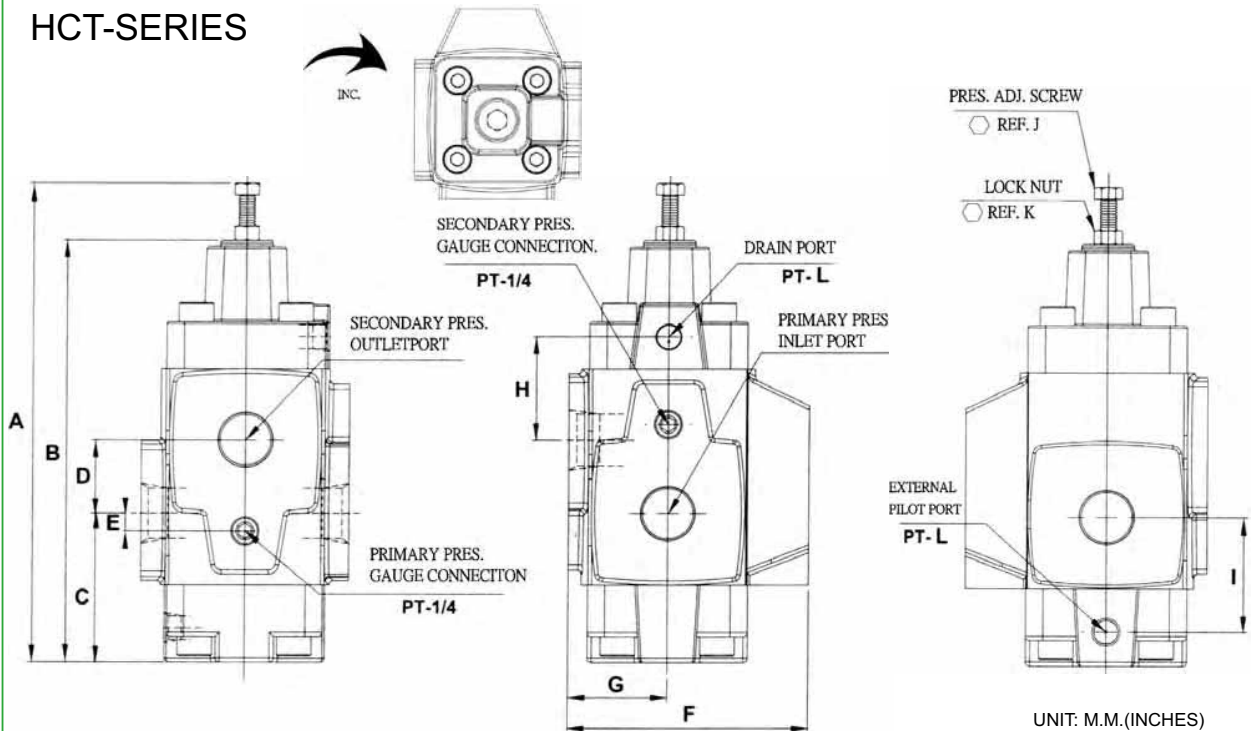

MODEL	A	B	C	D	E	F	G	H	I	J	K	L
HT-03	192(7.55)	167.5(6.59)	(58(2.28))	30(1.18)	0	95(3.74)	41.5(1.63)	39(1.53)	45(1.77)	13(0.51)	13(0.51)	1/8"
HT-06	223(8.77)	196(7.71)	69(2.71)	34(1.33)	8.3(0.32)	111(4.37)	46(1.81)	48(1.88)	53.5(2.08)	13(0.51)	13(0.51)	1/4"
HT-10	266(10.4)	246(9.68)	87(3.42)	40(1.57)	15(0.59)	154(6.06)	64(2.51)	58(2.28)	68(2.67)	5(0.19)	17(0.66)	1/4"

UNIT: M.M.(INCHES)



SOLTECH

PRESSURE CONTROLS

REDUCING PRESSURE VALVES

[RG/RT-03,06,10]

※SPECIFICATION

MODEL	SIZE	MAX. PRES. MPa(PSI)	MAX. FLOW ℓ/min(GPM)	WEIGHT (Kg)	
				RT	RG
RG, RT	03	25 (3630)	50(13.2)	4.2	4.6
	06		125(33)	7.4	7.2

※GRAPHIC SYMBOL

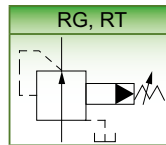

※MODEL NUMBER DESIGNATION

R	G	03	B	(90)
SERIES NO.	CONNECTION TYPE G: SUB-PLATE TYPE T: THREADED TYPE	VALVE SIZE 03: 3/8", ISO 5781-AG-06-2-A 06: 3/4", ISO 5781-AH-08-2-A	PRESSURE ADJ. RANGE MPa(psi) B:0.7~7(101.5~1015) C:3.5~14(507.5~2030) H:7~25(1015~3630)	DESIGN No. OMIT: DIN 912 BOLTS 90: UNC BOLTS (NORTH AMERICA)

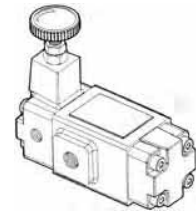

RT-03

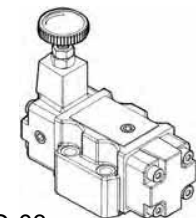

RG-03

※ACCESSORIES

MODEL	SOCKET HEAD SCREW CAP		O RING			
	European Design. Std.	N. America Design Std.				
RG-03	M10 × 50 Lg.	3/8-16 UNC × 2 Lg.	4 Pcs	P9	1 Pcs	P18 2 Pcs
RG-06	M10 × 50 Lg.	3/8-16 UNC × 2 Lg.	4 Pcs	P9	2 Pcs	P29 2 Pcs

※PRODUCTS LIST

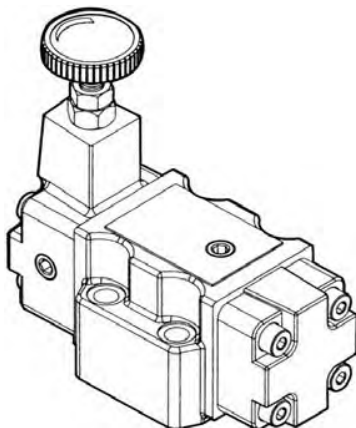

RG-03

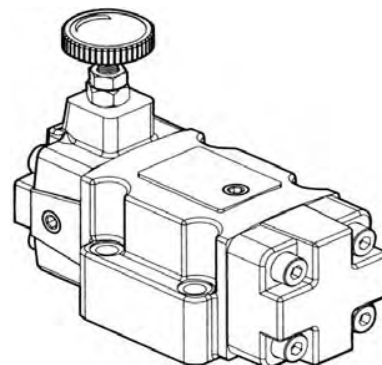

RG-06

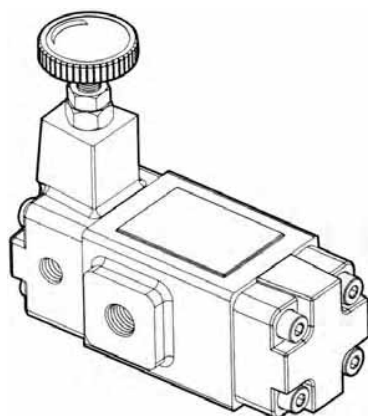

RT-03

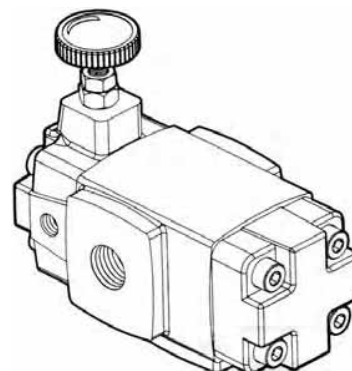

RT-06

C



SOLTECH

PRESSURE CONTROLS

REDUCING PRESSURE VALVES

RG-SERIES

DIMENSIONS

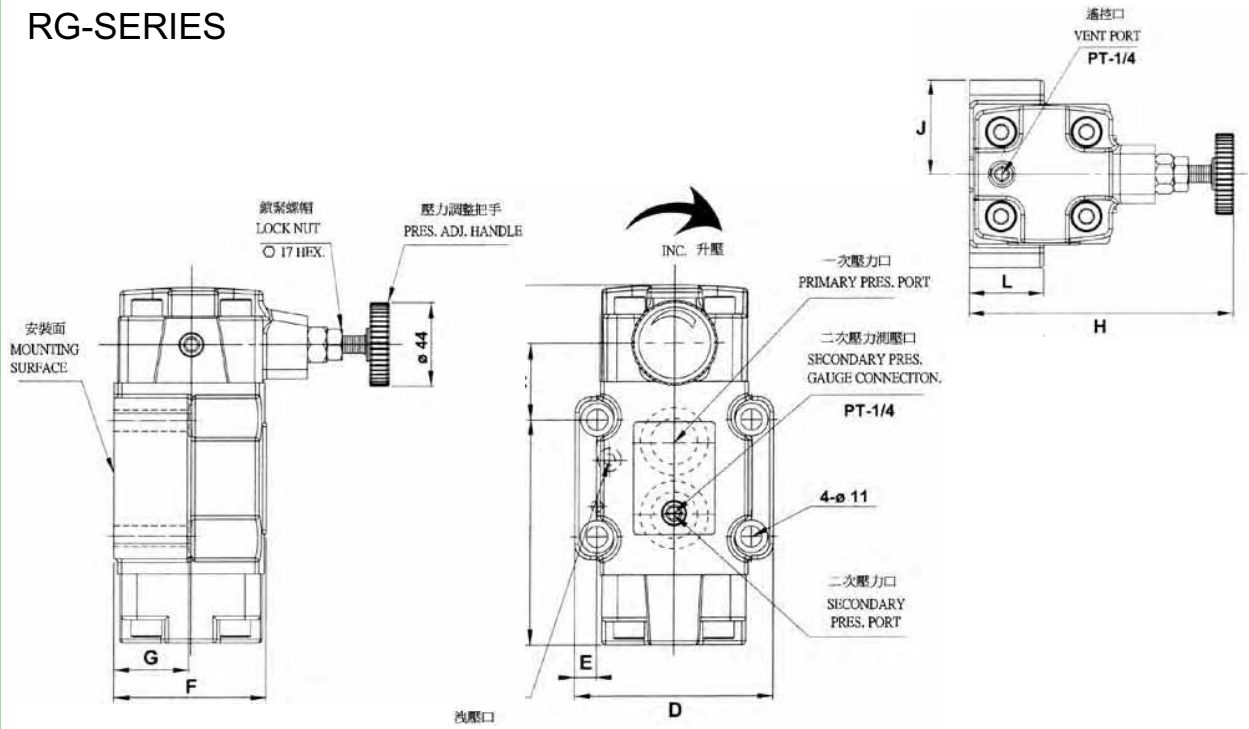

MODEL	A	B	C	D	E	F	G	H	I	J
RG-03	159(6.25)	93.5(3.68)	40.5(1.59)	89(3.50)	11.2(0.44)	69(2.71)	42(1.65)	145.5(5.72)	43(1.69)	44.5(1.75)
RG-06	186(7.32)	116.5(4.58)	40(1.57)	102(4.01)	11.3(0.44)	79(3.11)	39(1.53)	143(5.62)	40(1.57)	51(2.00)

UNIT: M.M.(INCHES)

RT-SERIES

DIMENSIONS

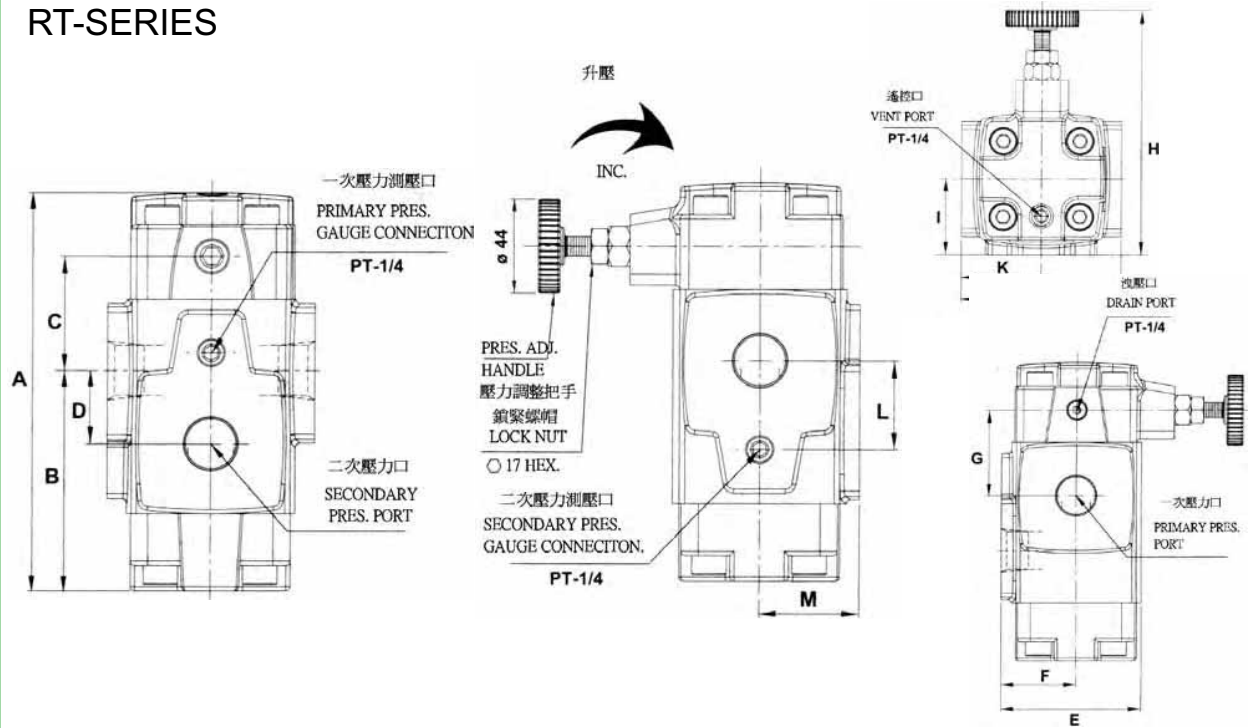

UNIT: M.M.(INCHES)

MODEL	A	B	C	D	E	F	G	H	I	J	K	L	M
RT-03	159(6.25)	86(3.38)	48(1.88)	30(1.18)	74(2.91)	41.5(1.63)	47(1.85)	151(5.94)	42(1.65)	80(3.14)	40(1.57)	30(1.18)	41.5(1.63)
RT-06	186(7.32)	103(4.05)	53(2.08)	34(1.33)	86(3.38)	46(1.81)	53(2.08)	148.5(5.84)	46(1.81)	96(3.77)	48(1.88)	42(1.65)	46(1.81)



SOLTECH

PRESSURE CONTROLS

REDUCING PRESSURE WITH CHECK VALVES

【 RCG/RCT-03,06,10 】

※SPECIFICATION

MODEL	SIZE	MAX. PRES. MPa(Psi)	MAX. FLOW ℓ/min(GPM)	WEIGHT (Kg)	
				RCT	RCG
RCG, RCT	03	25 (3630)	50(13.2)	4.5	5.5
	06		125(33)	7.8	8.2

※GRAPHIC SYMBOL

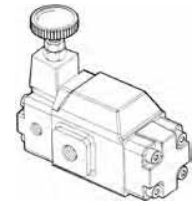
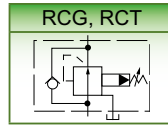

RCT-03

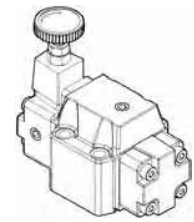

RCG-03

※MODEL NUMBER DESIGNATION

RC	G	03	B	(90)
SERIES NO. RC: REDUCING ADDED TO DESIGNATED INTEGRAL CHECK	CONNECTION TYPE G: SUB-PLATE TYPE T: THREADED TYPE	VALVE SIZE 03: 3/8", ISO 5781-AG-06-2-A 06: 3/4", ISO 5781-AH-08-2-A	PRESSURE ADJ. RANGE MPa(psi) B:0.7~7(101.5~1015) C:3.5~14(507.5~2030) H:7~25(1015~3630)	DESIGN No. OMIT: DIN 912 BOLTS 90: UNC BOLTS (NORTH AMERICA)

※ACCESSORIES

MODEL	SOCKET HEAD SCREW CAP				O RING					
	European Design. Std.	N. America Design Std.								
RCG-03	M10 × 75 Lg.	3/8-16 UNC × 2-3/4 Lg.	4	Pcs	P9	1	Pcs	P18	2	Pcs
RCG-06	M10 × 85 Lg.	3/8-16 UNC × 3-1/4 Lg.	4	Pcs	P9	2	Pcs	P29	2	Pcs

※PERFORMANCE CURVES

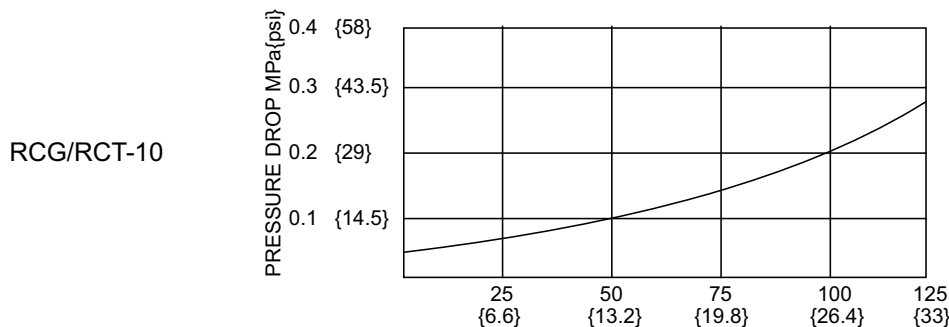
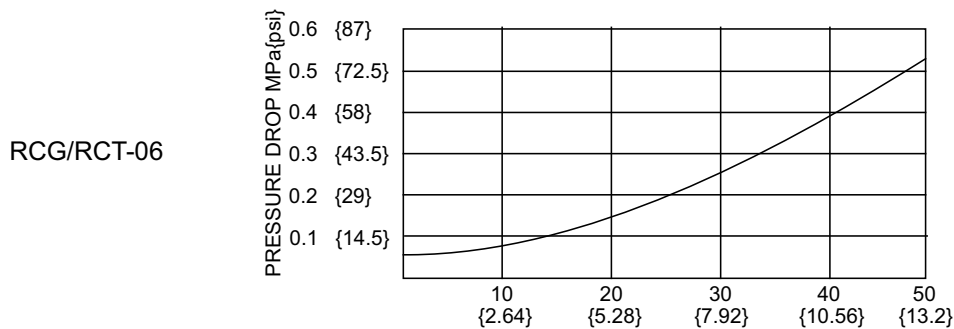
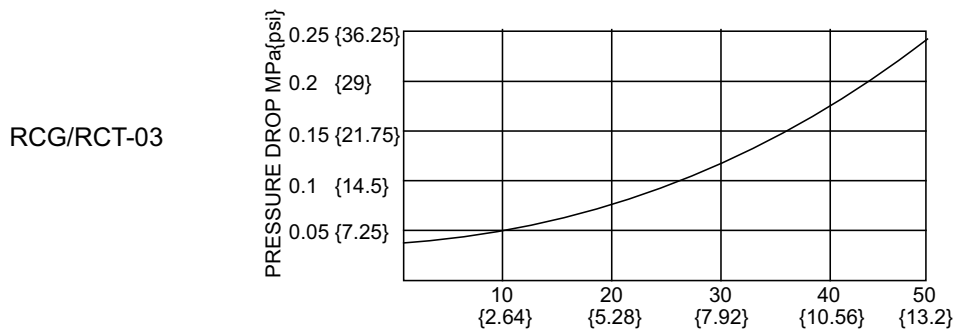



SOLTECH

PRESSURE CONTROLS

REDUCING PRESSURE WITH CHECK VALVES

RCG-SERIES

DIMENSIONS

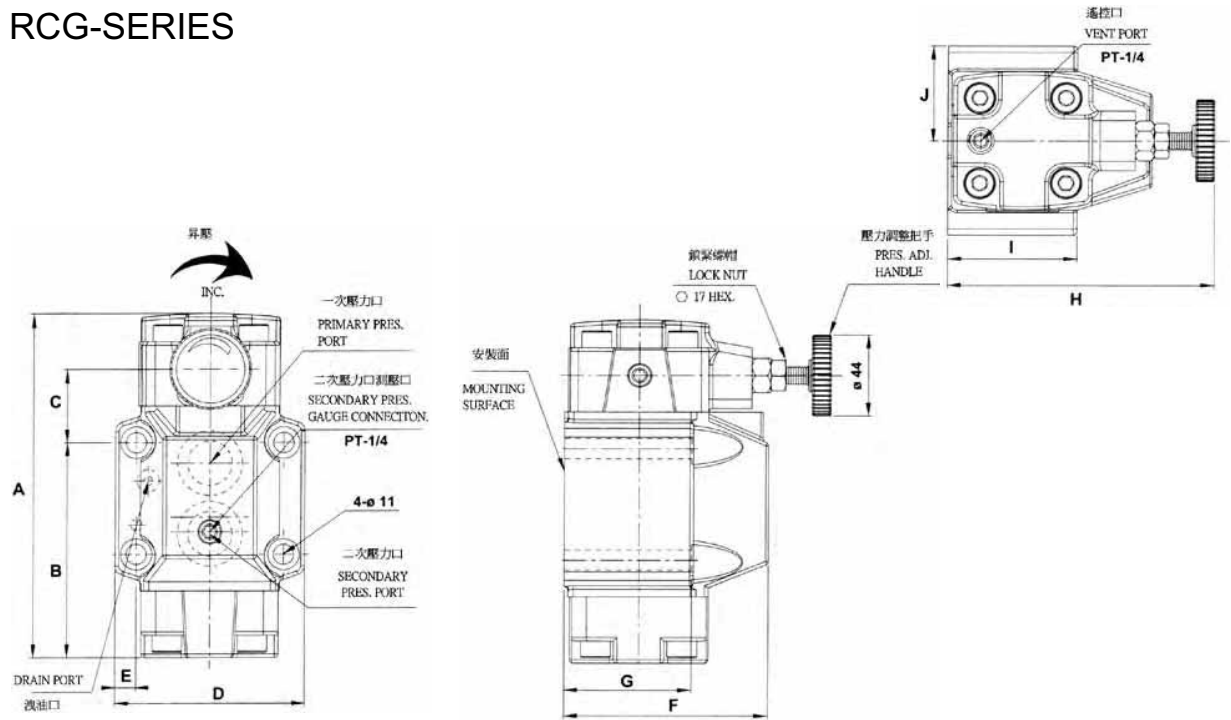

MODEL	A	B	C	D	E	F	G	H	I	J
RG-03	159(6.25)	93.5(3.68)	40.5(1.59)	89(3.50)	11.2(0.44)	69(2.71)	42(1.65)	145.5(5.72)	43(1.69)	44.5(1.75)
RG-06	186(7.32)	116.5(4.58)	40(1.57)	102(4.01)	11.3(0.44)	79(3.11)	39(1.53)	143(5.62)	40(1.57)	51(2.00)

UNIT: M.M.(INCHES)

DIMENSIONS

RCT-SERIES

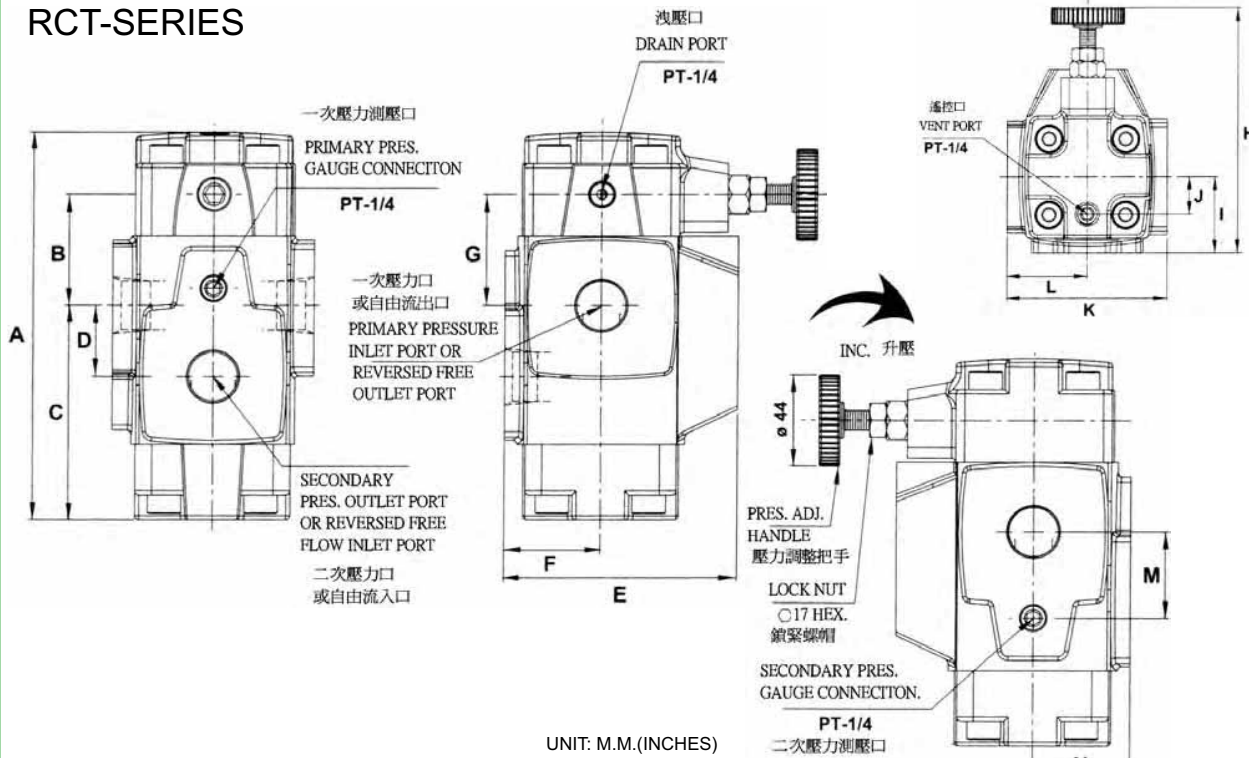

UNIT: M.M.(INCHES)

MODEL	A	B	C	D	E	F	G	H	I	J	K	L	M
RT-03	159(6.25)	86(3.38)	48(1.88)	30(1.18)	74(2.91)	41.5(1.63)	47(1.85)	151(5.94)	42(1.65)	80(3.14)	40(1.57)	30(1.18)	41.5(1.63)
RT-06	186(7.32)	103(4.05)	53(2.08)	34(1.33)	86(3.38)	46(1.81)	53(2.08)	148.5(5.84)	46(1.81)	96(3.77)	48(1.88)	42(1.65)	46(1.81)



SOLTECH

PRESSURE CONTROLS

MOUNTING INTERFACE

C

DIMENSIONS

BR-SERIES
BG-SERIES
DB-SERIES
SBG-SERIES

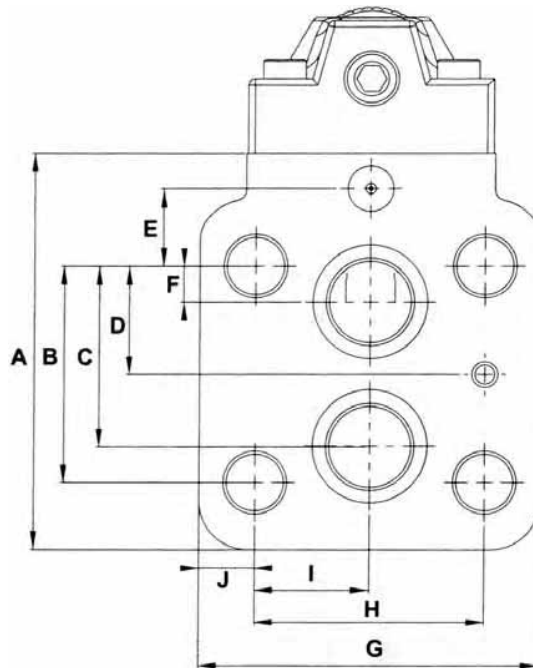

MODEL	A	B	C	D	E	F	G
03	53.8(2.11)	47.4(1.86)	22(0.86)	22(0.86)	0	53.8(2.11)	26.9(1.05)
06	66.7(2.62)	55.5(2.18)	33.4(1.31)	11(0.43)	23.8(0.93)	70(2.75)	35(1.37)
10	88.9(3.50)	76.2(3.00)	44.5(1.75)	12.7(0.50)	31.8(1.25)	82.6(3.25)	41.3(1.62)

UNIT: M.M.(INCHES)

DIMENSIONS

RG-03
HG-03
HCG-03
CPDG-03

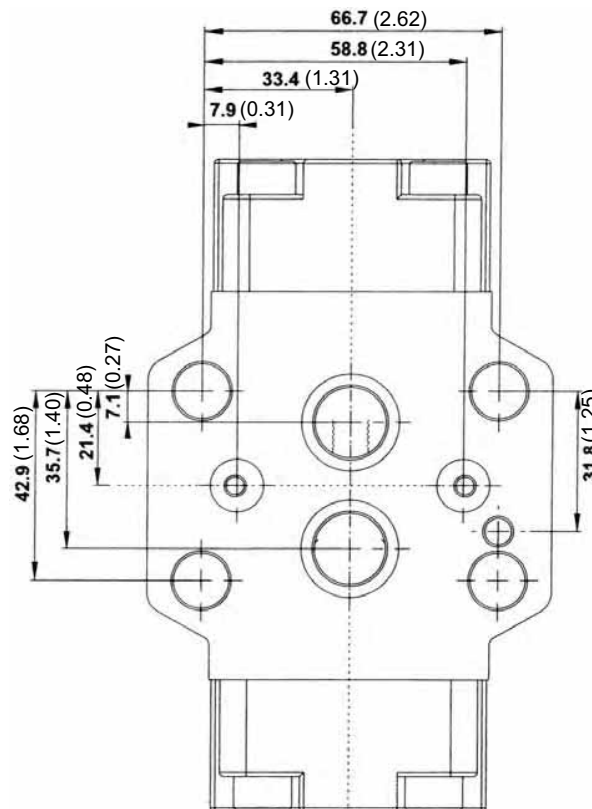

UNIT: M.M.(INCHES)

